

OKHA

FULL CATALOGUE
SPECIFICATION

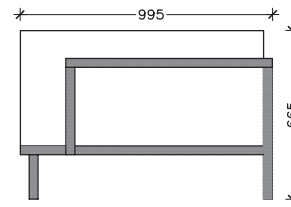

LEATHER OPTIONS | OPTIONAL C.O.M

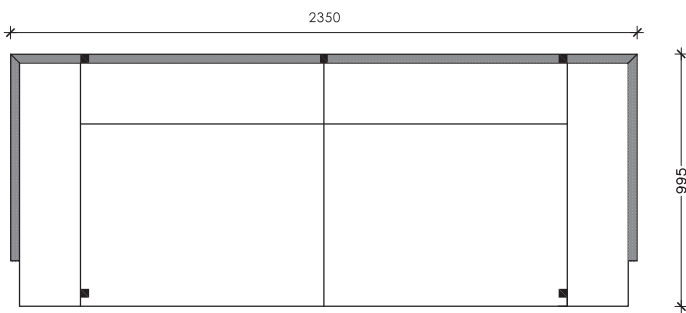
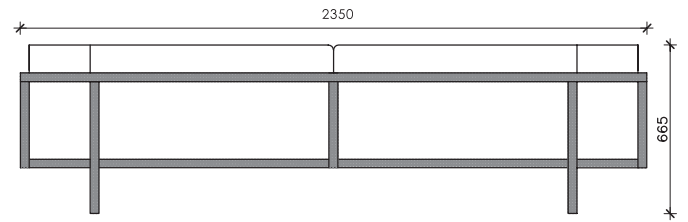
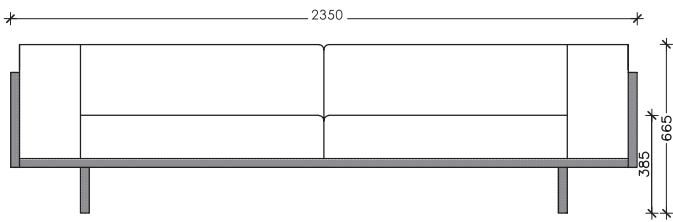

WOOD OPTIONS



DIMENSIONS

2350W x 995D x 665H mm | SEAT HEIGHT: 385mm

DESCRIPTION

Solid wood frame construction, dual density foam cushion with down overlay.
Base options: solid oak available in natural, white or carbon stain. Also available in walnut.

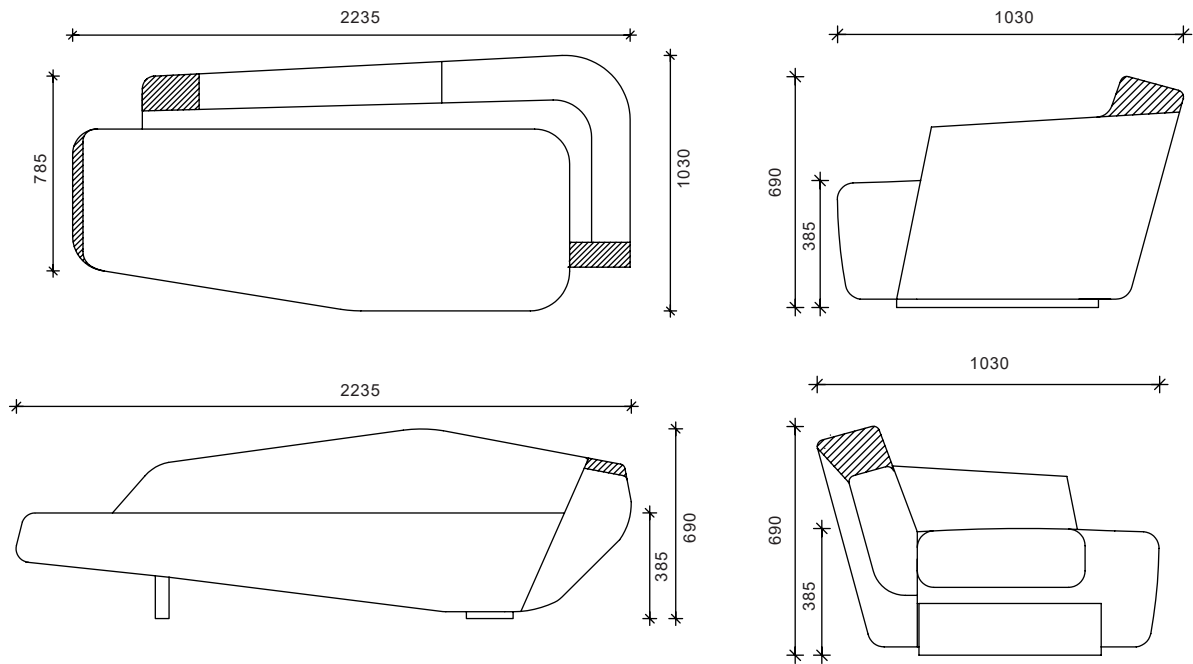

LEATHER OPTIONS | OPTIONAL C.O.M



Black

Mocca

Navy

Straw

Anthracite

Elephant

Oyster

Latte

White

WOOD OPTIONS



Natural Oak

Carbon Oak

Chalked Oak

Dark Java Ash

Natural Ash

Carbon Ash

Walnut

Dark Java Oak

DIMENSIONS

2235W x 1030D x 690H mm | SEAT HEIGHT: 385mm

DESCRIPTION

Solid wood frame construction, perspex feet, dual density foam cushion.

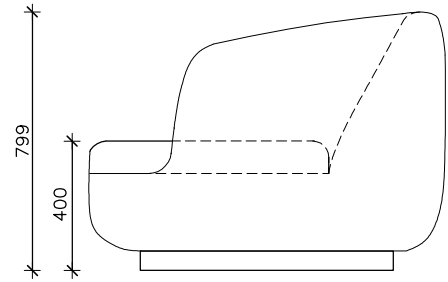
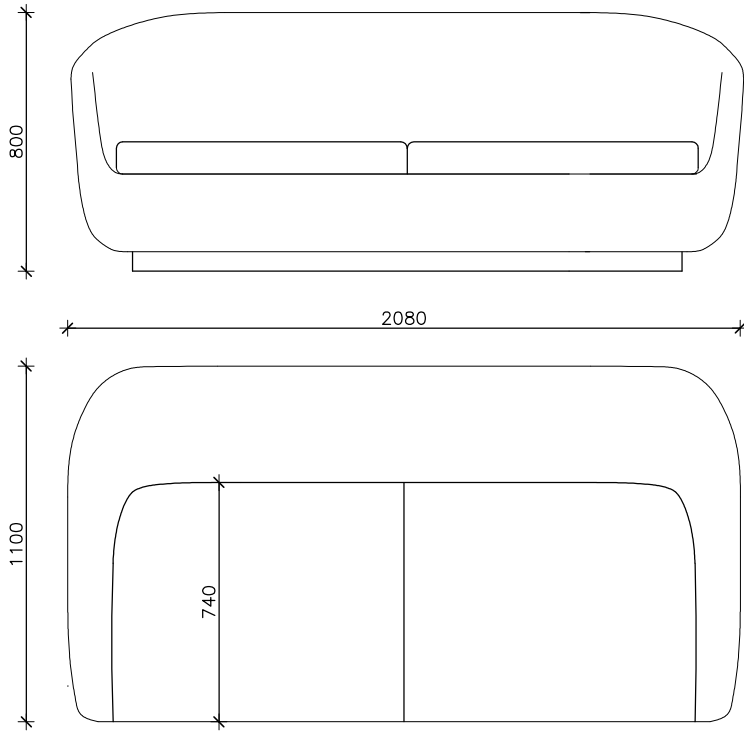

LEATHER OPTIONS | OPTIONAL C.O.M



DIMENSIONS

2080W x 1100D x 800H mm | SEAT HEIGHT: 400 mm

DESCRIPTION

Solid ash available in natural, white or carbon stain.

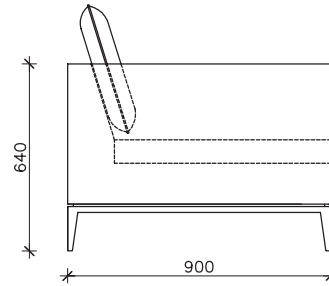
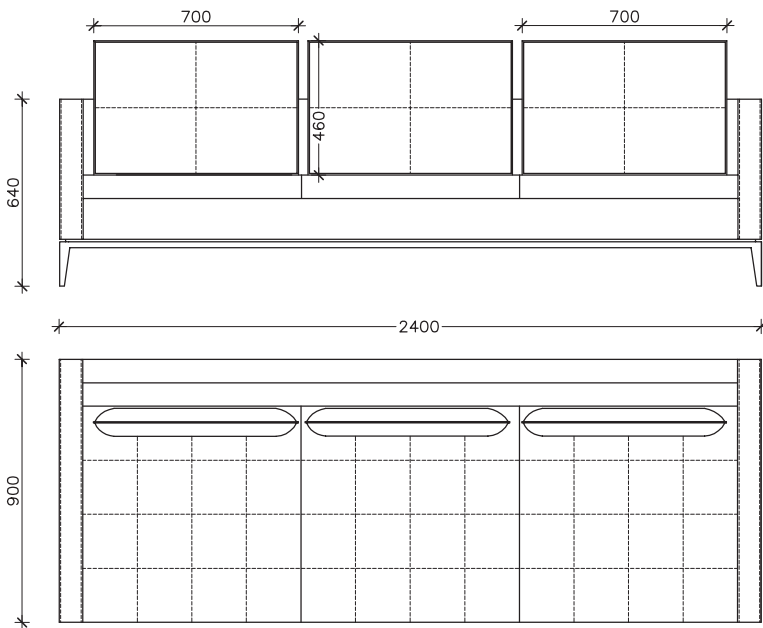

LEATHER OPTIONS | OPTIONAL C.O.M



WOOD OPTIONS



DIMENSIONS

2 SEATER: 1760W x 900D x 640H mm | SEAT HEIGHT: 380 mm
 3 SEATER: 2400W x 900D x 640H mm | SEAT HEIGHT: 380 mm

DESCRIPTION

Solid wood frame construction, dual density foam cushion.
 Base options: solid ash available in natural, white or carbon stain.
 Also available in walnut or mirror polished stainless steel.

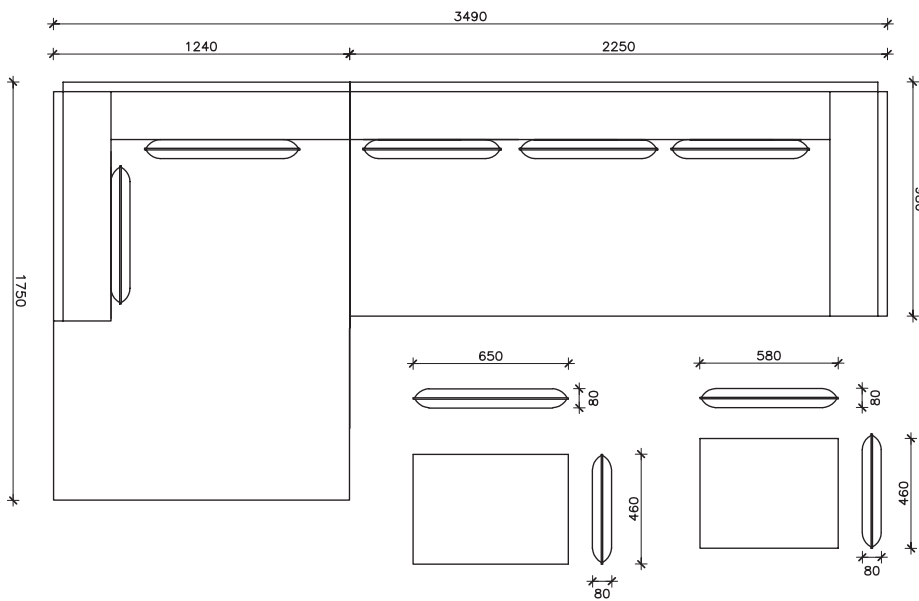

LEATHER OPTIONS | OPTIONAL C.O.M



DIMENSIONS

MODULE: 2250W x 980D x 650H mm / 1240W x 1750D x 650H mm
SEAT HEIGHT: 370 mm

DESCRIPTION

Solid wood frame construction, dual density foam cushion.
Base options: black or white powder coated or mirror polished stainless steel.

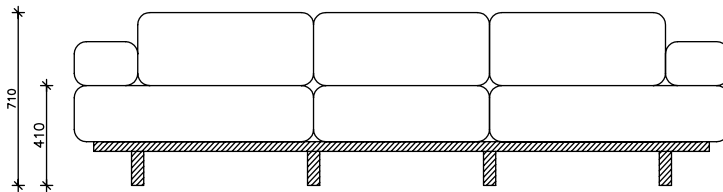
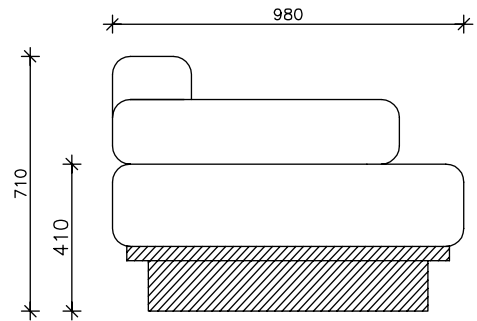
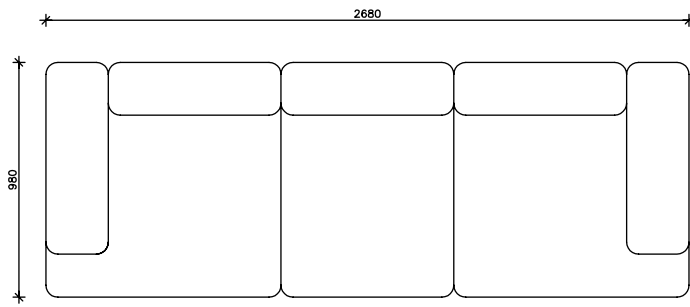

LEATHER OPTIONS | OPTIONAL C.O.M



WOOD OPTIONS



DIMENSIONS

2680W x 980D x 710H mm | SEAT HEIGHT: 410 mm

DESCRIPTION

Solid wood frame construction, dual density foam cushion, upholstered with loose back scatter cushions.

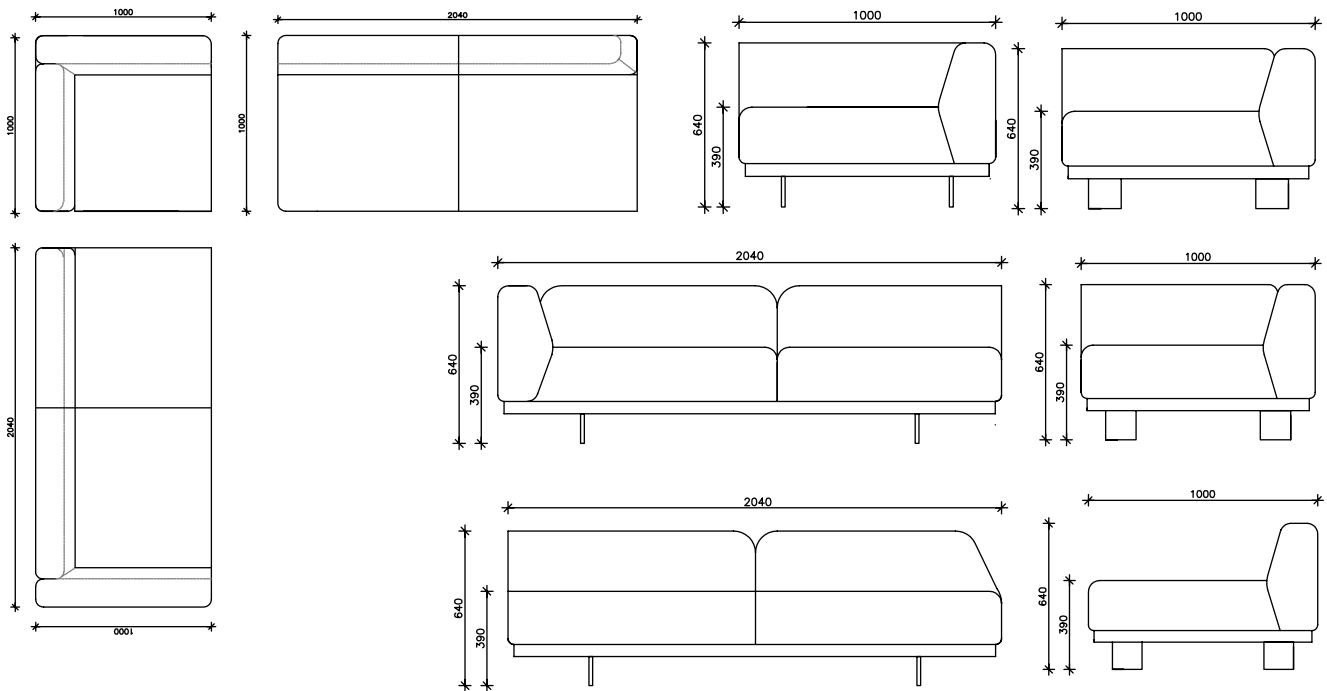

LEATHER OPTIONS | OPTIONAL C.O.M



DIMENSIONS

2040W x 1000D x 640H / 1000W x 1000D x 640H / 2040W x 1000D x 640H
SEAT HEIGHT: 390 mm

DESCRIPTION

Solid wood frame construction, dual density foam cushion.

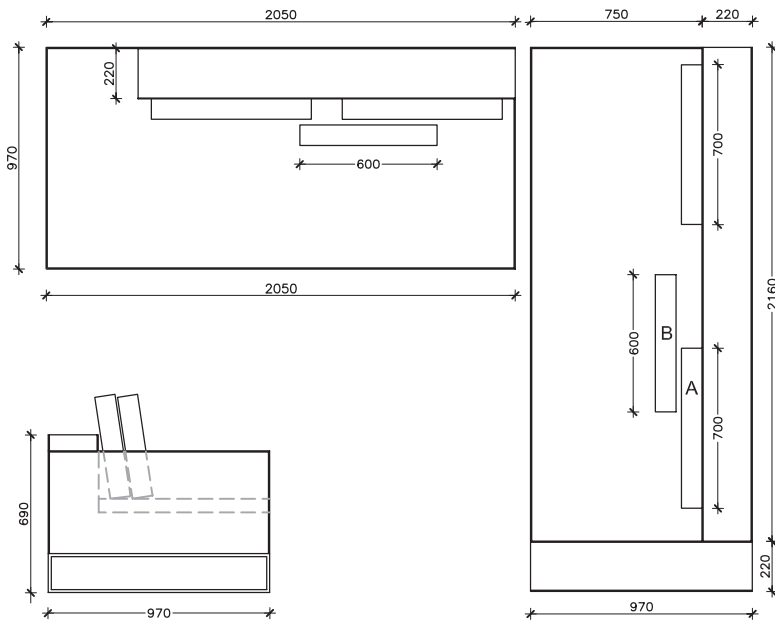

LEATHER OPTIONS | OPTIONAL C.O.M



DIMENSIONS

SOFT BOX: 2700W x 970D x 690H mm | L-SHAPE: 2050W / 2380W x 970D x 690H mm
 MODULAR: 1930W / 2050W x 970D x 690H mm | SEAT HEIGHT: 410 mm

DESCRIPTION

Solid wood frame construction, dual density foam cushion.
 Base options: black or white powder coated mild steel.
 Also available in walnut.

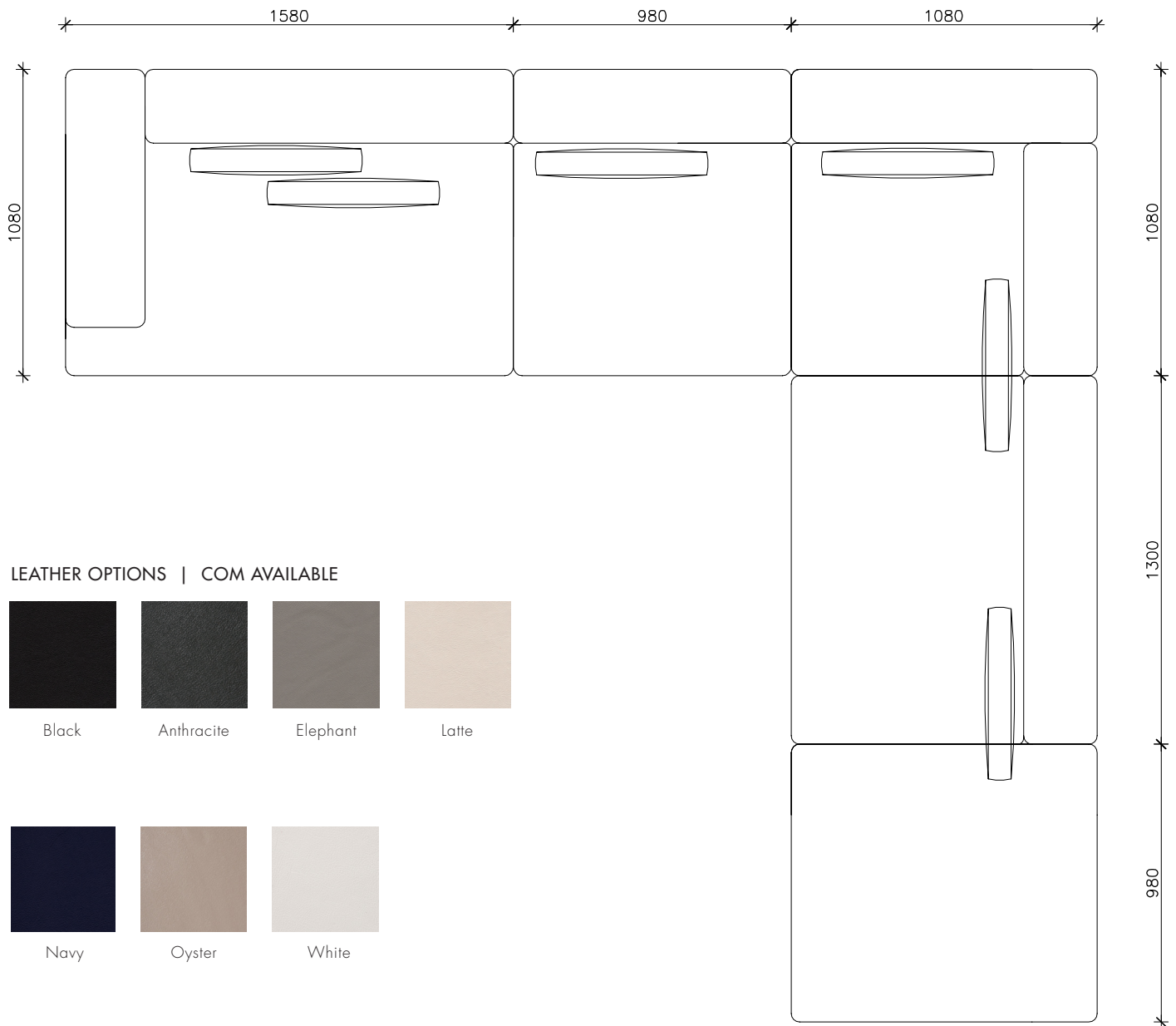

DIMENSIONS

1580 W / 980 W / 1080 W / 1300 W x 1080D x 660H mm
OTTOMAN: 980W x 1080D mm | SEAT HEIGHT: 370 mm

DESCRIPTION

Solid wood frame construction, twin layer dual density foam seat cushion and back rest with leather trim base detail. Stained ash plinth below.

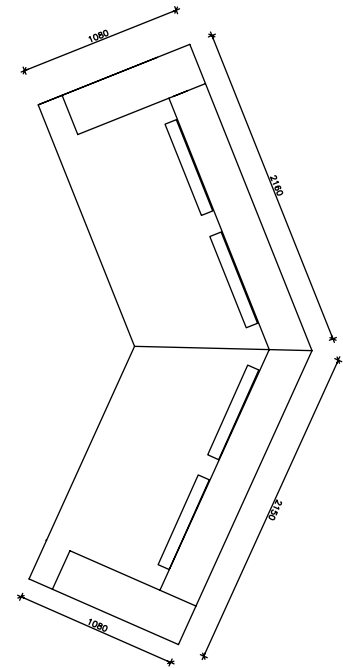
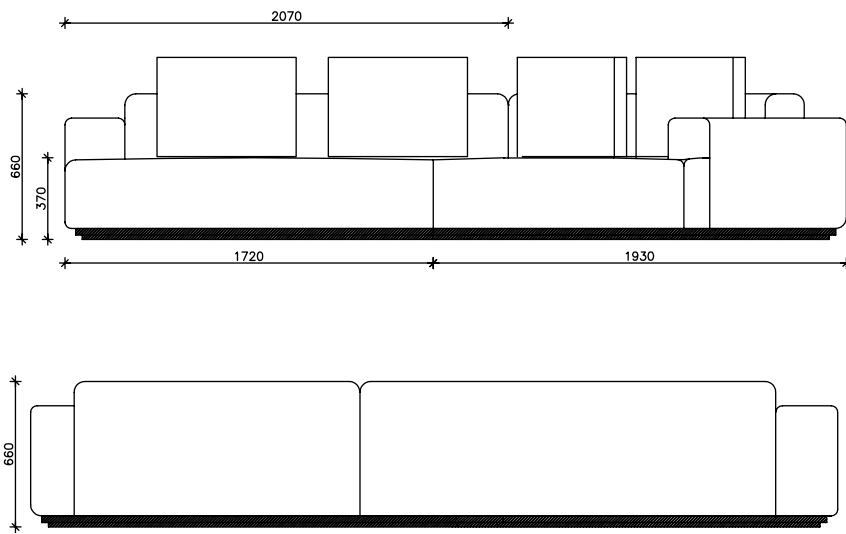

LEATHER OPTIONS | OPTIONAL C.O.M



WOOD OPTIONS



DIMENSIONS

2160W x 1080D x 660H / 2150W x 1080D x 660H mm
 MAX AREA: 3660W x 2300D SEAT HEIGHT: 370 mm

DESCRIPTION

Solid wood frame construction, dual density foam cushion.

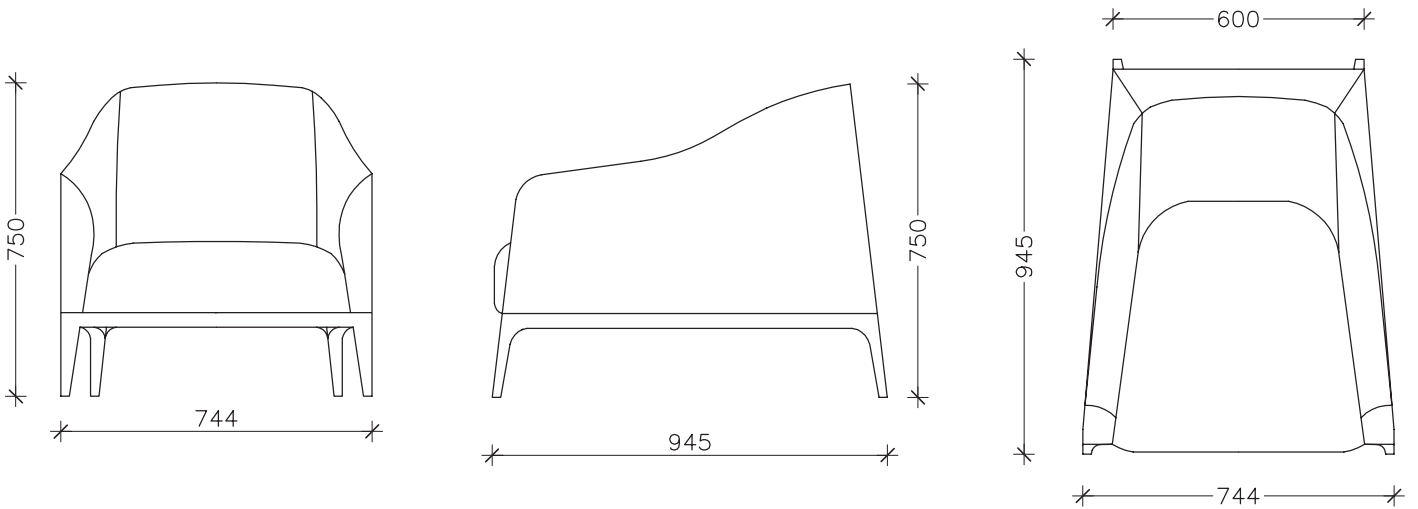

LEATHER OPTIONS | OPTIONAL C.O.M



WOOD OPTIONS



DIMENSIONS

744W x 945D x 750H mm | SEAT HEIGHT 370 mm

DESCRIPTION

Solid wood frame construction, sprung seat and back, dual density foam core seat. Base options: solid ash available in natural, white or carbon stain.

Also available in walnut.

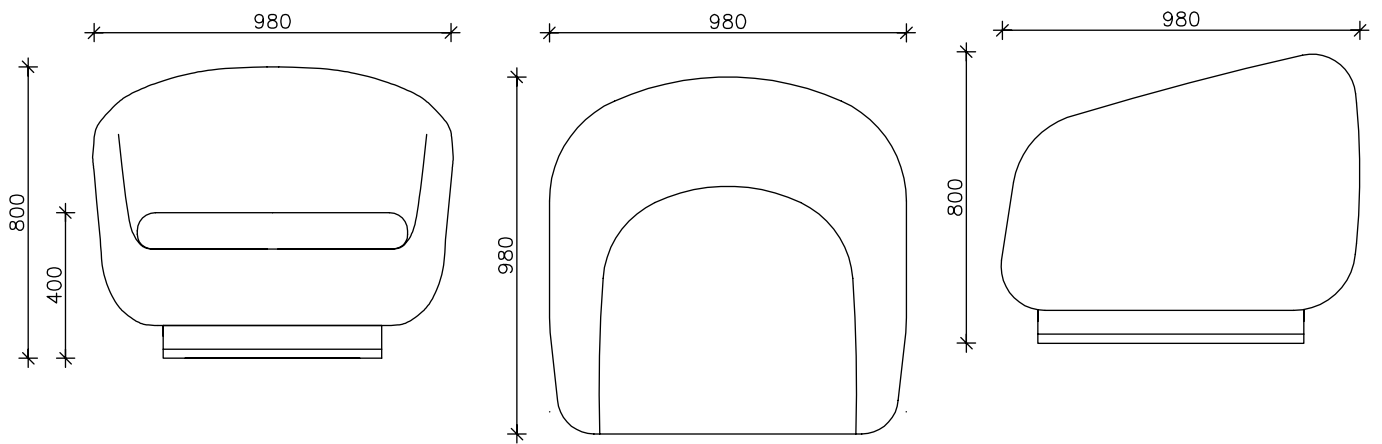

LEATHER OPTIONS | OPTIONAL C.O.M



WOOD OPTIONS



DIMENSIONS

980W x 980D x 800H mm | SEAT HEIGHT 400 mm

DESCRIPTION

Solid wood frame construction, dual density foam cushion with fully upholstered base. Base options: Ash, Oak and Walnut.

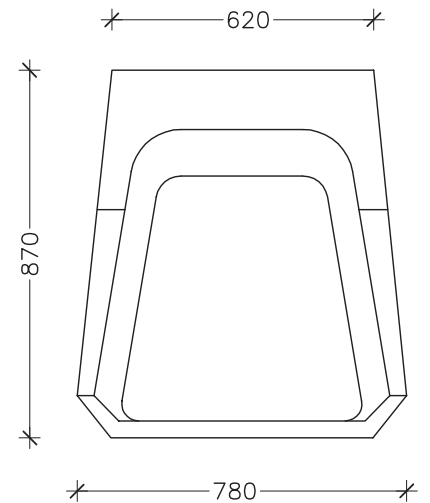
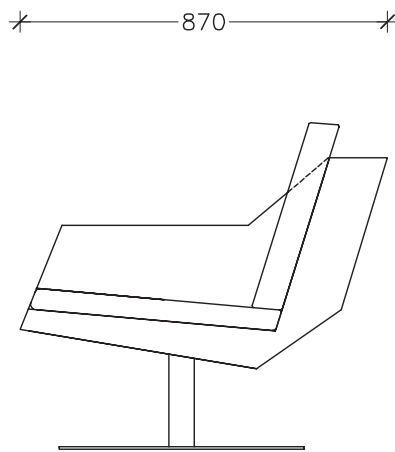
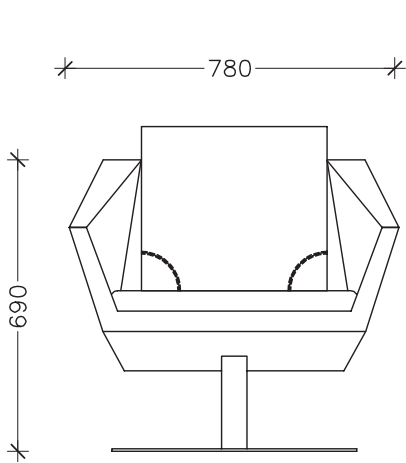

LEATHER OPTIONS | OPTIONAL C.O.M



WOOD OPTIONS

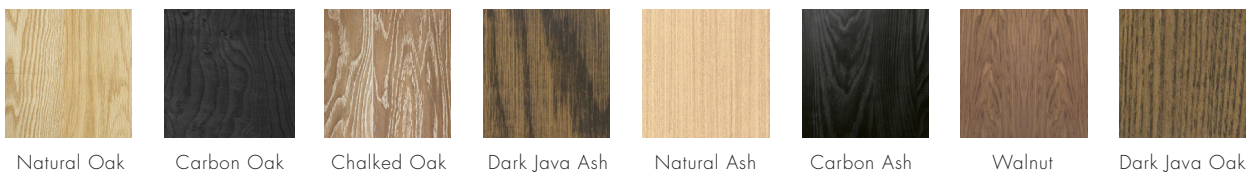

DIMENSIONS

780W x 870D x 690H mm | SEAT HEIGHT 380 mm

DESCRIPTION

Solid wood frame construction, dual density foam cushion.
Base options: black or white powder coated mild steel.

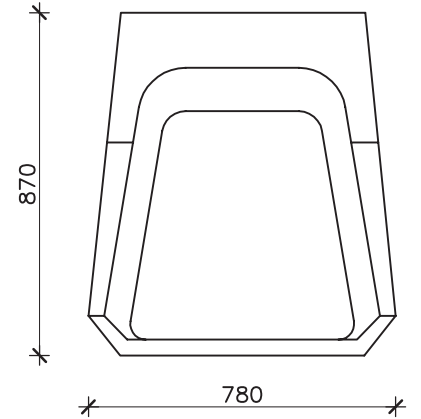
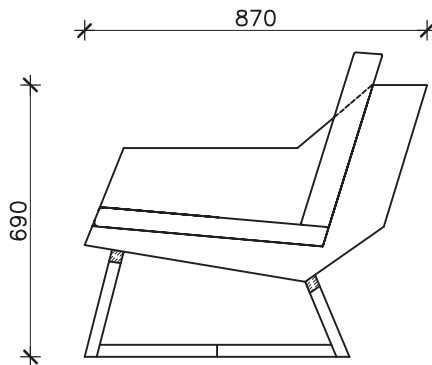
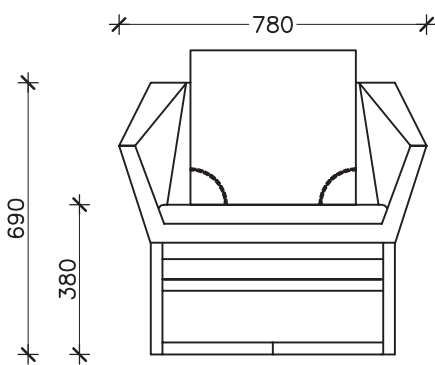

LEATHER OPTIONS | OPTIONAL C.O.M



WOOD OPTIONS



DIMENSIONS

780W x 870D x 690H mm | SEAT HEIGHT 380 mm

DESCRIPTION

Solid wood frame construction, dual density foam cushion.
Base options: ash & oak available in natural, white or carbon stain.
Also available in walnut.

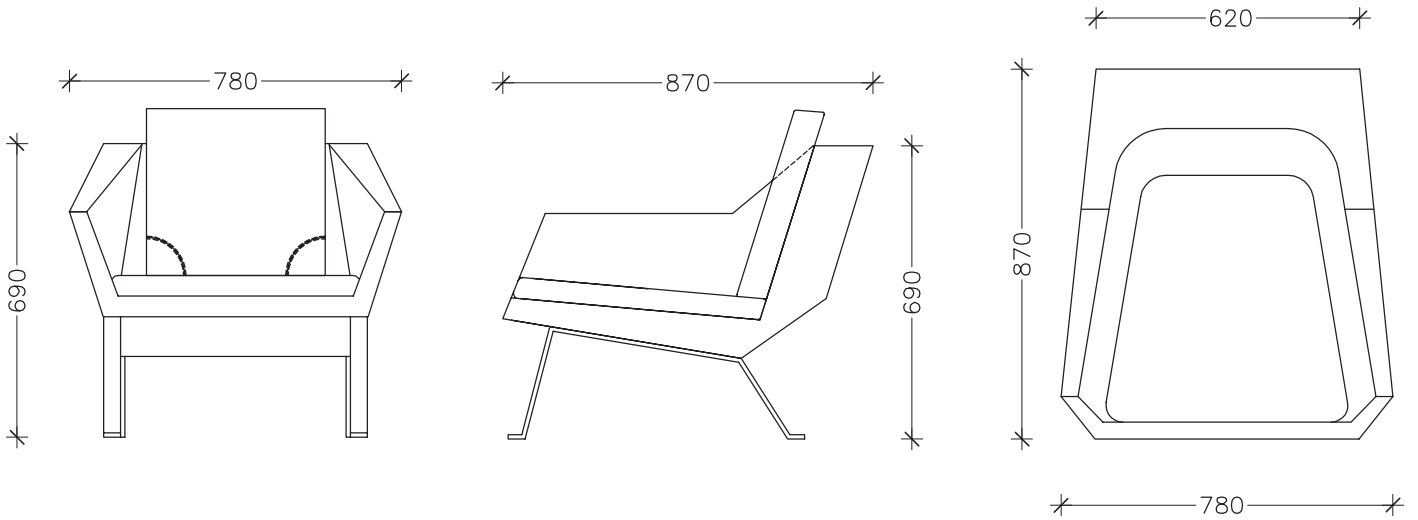

LEATHER OPTIONS | OPTIONAL C.O.M



WOOD OPTIONS



DIMENSIONS

780W x 870D x 690H mm | SEAT HEIGHT 380 mm

DESCRIPTION

Solid wood frame construction, dual density foam cushion.
Mirror polished stainless steel base.

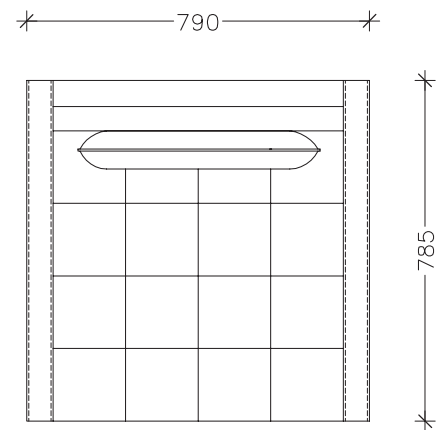
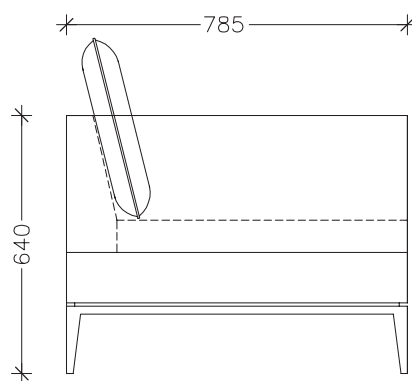
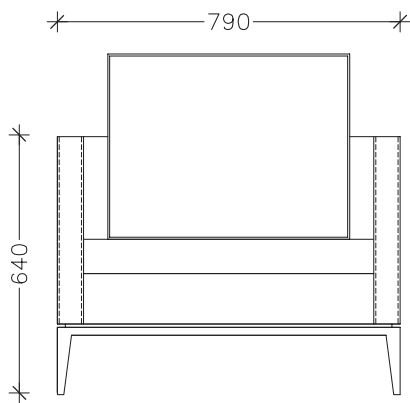

LEATHER OPTIONS | OPTIONAL C.O.M



WOOD OPTIONS



DIMENSIONS

790W x 785D x 640H mm | SEAT HEIGHT 380 mm

DESCRIPTION

Solid wood frame construction, dual density foam cushion. Base options: solid ash available in natural, white or carbon stain. Also available in mirror polished stainless steel and walnut.

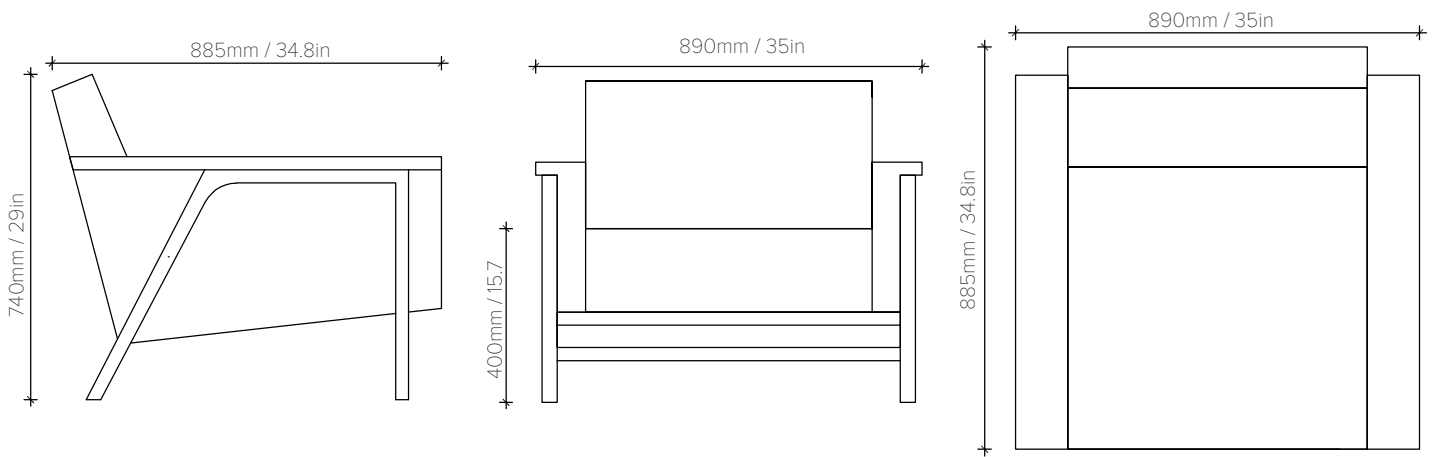

LEATHER OPTIONS | COM AVAILABLE



Black

Mocca

Navy

Straw

Anthracite

Elephant

Oyster

Latte

White

WOOD OPTIONS



Natural Oak

Carbon Oak

Chalked Oak

Dark Java Ash

Natural Ash

Carbon Ash

Walnut

Dark Java Oak

DIMENSIONS

890W x 885D x 740H mm | SEAT HEIGHT 400 mm | 35W x 34.8D x 29 in | SEAT HEIGHT 15.7 in

DESCRIPTION

Solid wood frame construction, dual density foam cushion.

Frame options: ash & oak available in natural, white or carbon stain.

Also available in walnut.

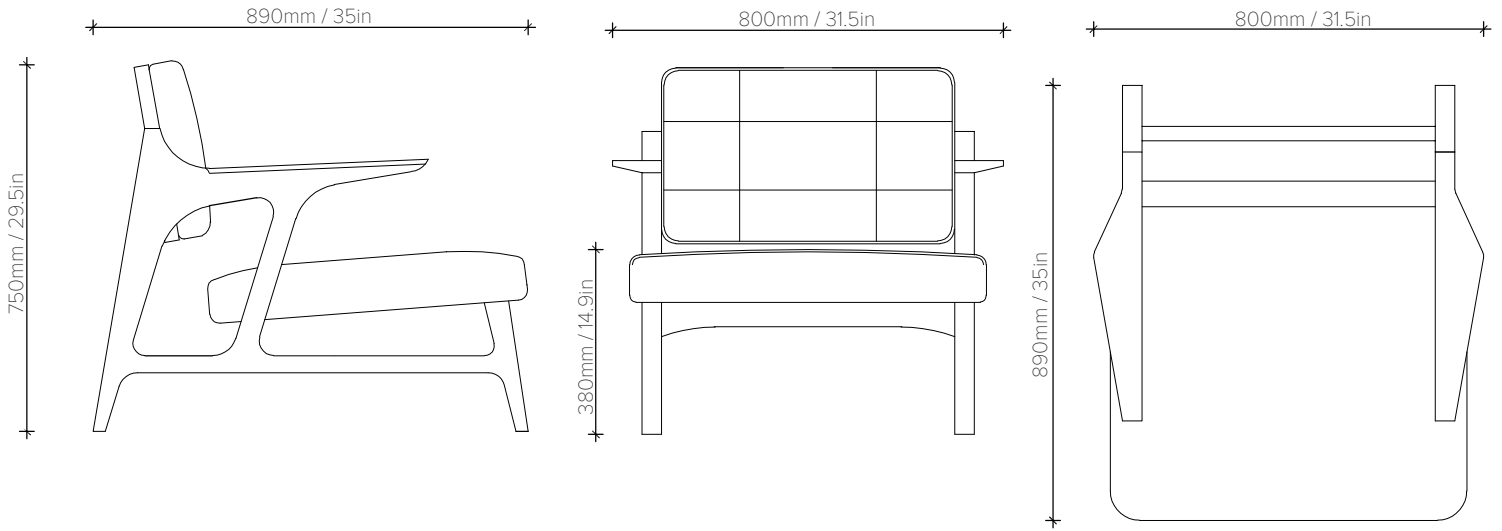

LEATHER OPTIONS | OPTIONAL C.O.M



WOOD OPTIONS



DIMENSIONS

800W x 890D x 750H mm | SEAT HEIGHT 380 mm | 31.5W x 35D x 29.5H in | SEAT HEIGHT 14.9 in

DESCRIPTION

Solid oak frame, upholstered dual density foam seat.

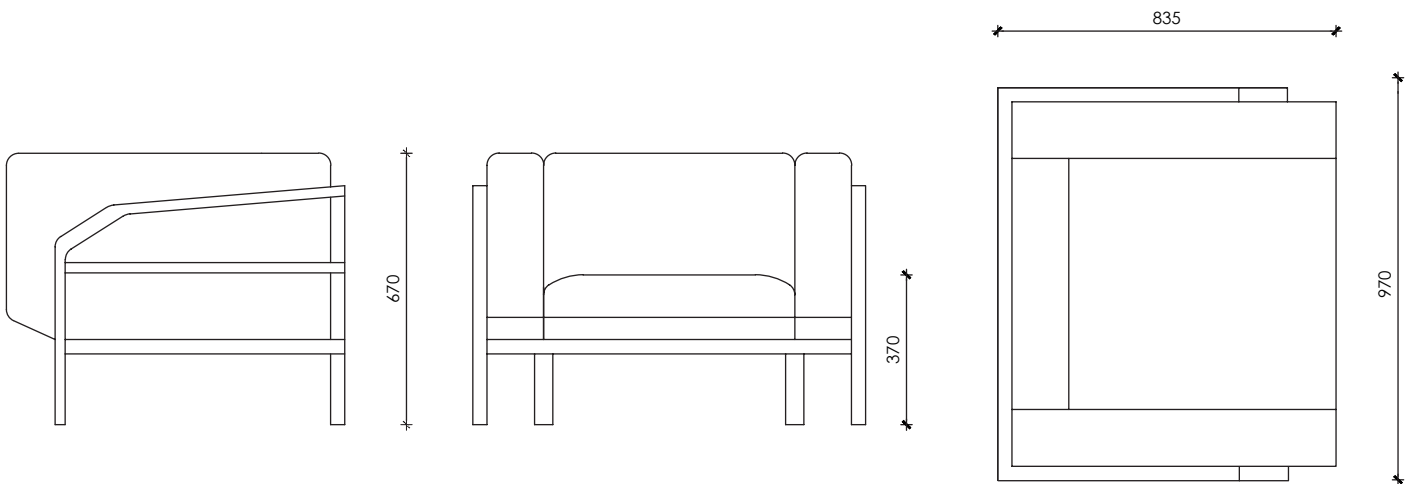

LEATHER OPTIONS | OPTIONAL C.O.M



WOOD OPTIONS



DIMENSIONS

970W x 835D x 670H mm | SEAT HEIGHT 370 mm

DESCRIPTION

Solid oak frame, upholstered dual density foam seat.

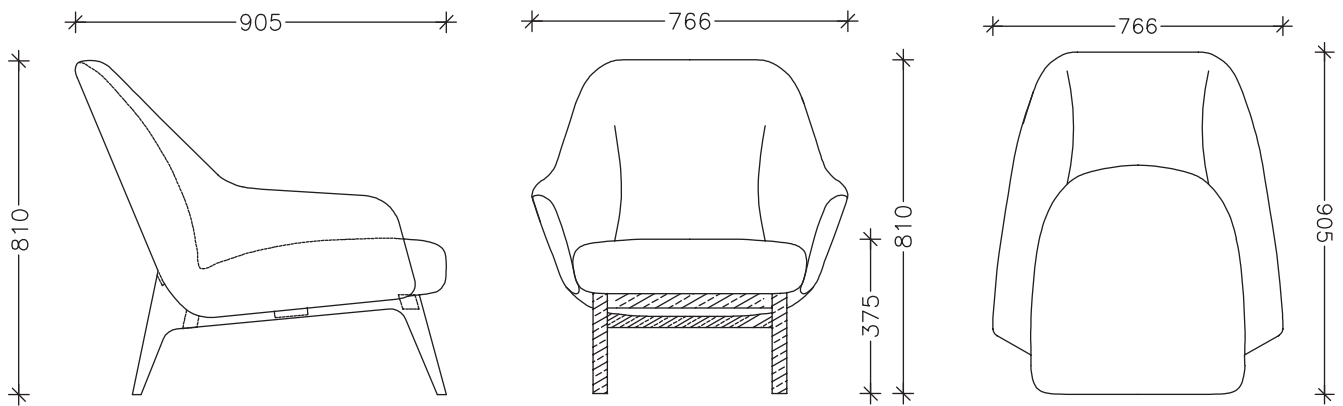

LEATHER OPTIONS | OPTIONAL C.O.M



WOOD OPTIONS



DIMENSIONS

766W x 905D x 810H mm | SEAT HEIGHT 375mm

DESCRIPTION

Solid wood frame construction, dual density foam cushion.
Base options: solid ash available in natural, white or carbon stain.
Also available in walnut.

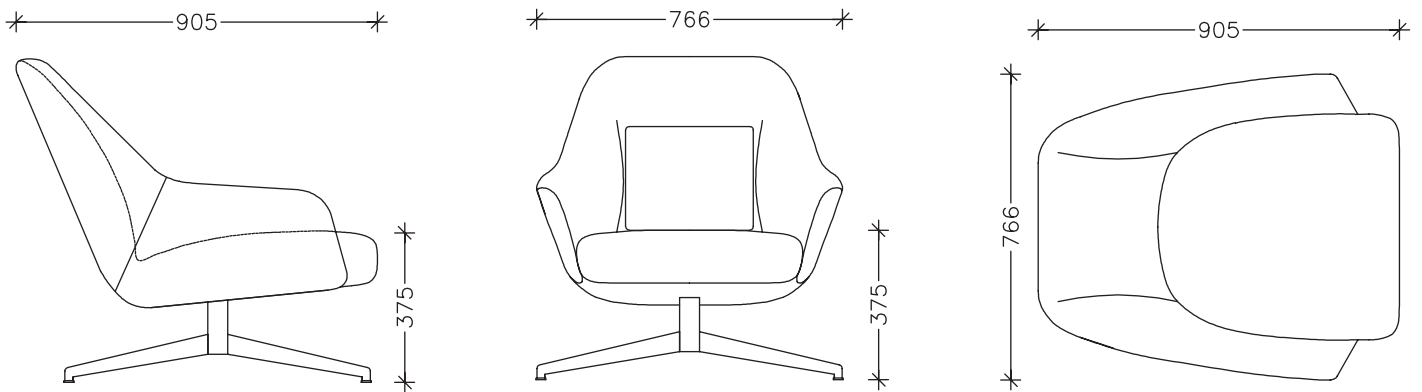

LEATHER OPTIONS | OPTIONAL C.O.M



WOOD OPTIONS



DIMENSIONS

766W x 905D x 810H mm | SEAT HEIGHT 375mm

DESCRIPTION

Solid wood frame construction, dual density foam cushion.
Base options: black or white powder coated mild steel swivel base
or stainless steel swivel base.

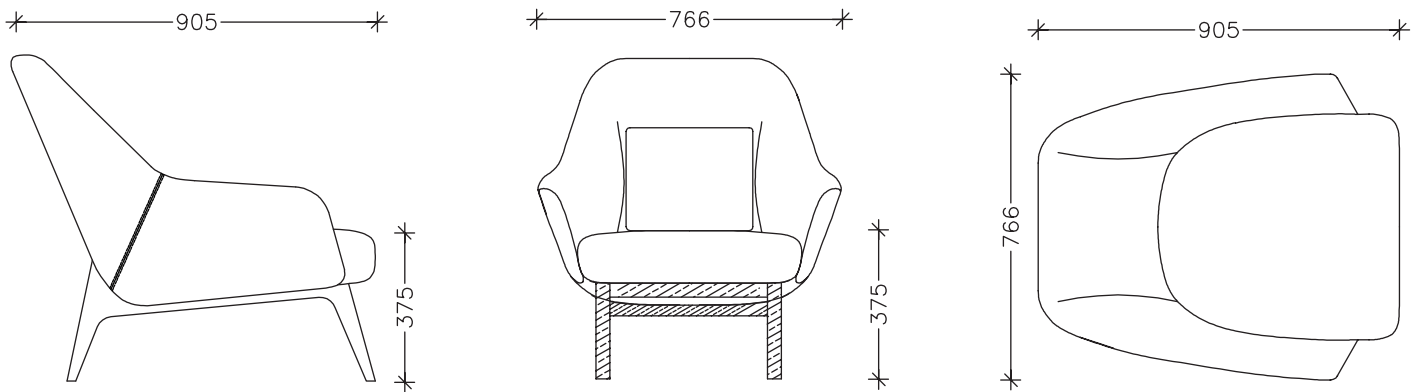

LEATHER OPTIONS | OPTIONAL C.O.M



WOOD OPTIONS



DIMENSIONS

766W x 905D x 810H mm | SEAT HEIGHT 375mm

DESCRIPTION

Solid wood frame construction, dual density foam cushion.
Base options: black or white powder coated mild steel swivel base
or stainless steel swivel base.

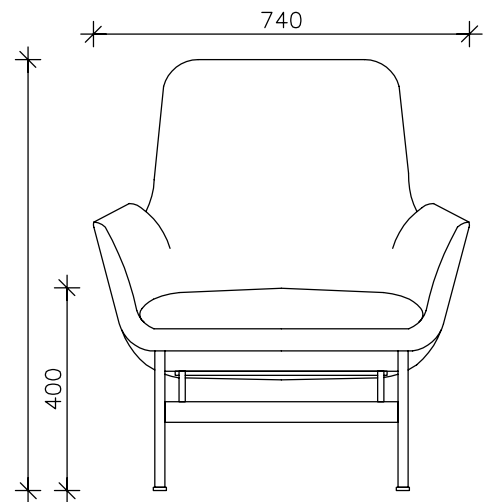
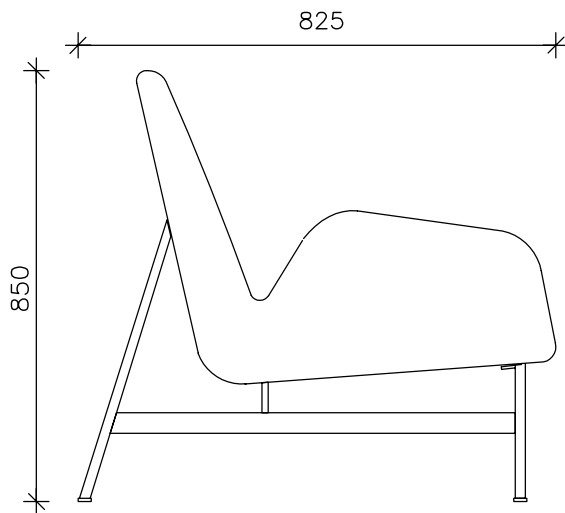

LEATHER OPTIONS | OPTIONAL C.O.M



WOOD OPTIONS



DIMENSIONS

740W x 825D x 850H (mm) - Seat Height: 400 (mm)

DESCRIPTION

Mild Steel base frame construction in Ferrogroin powdercoating, dual density foam cushion and upholstered.

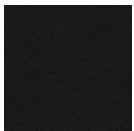
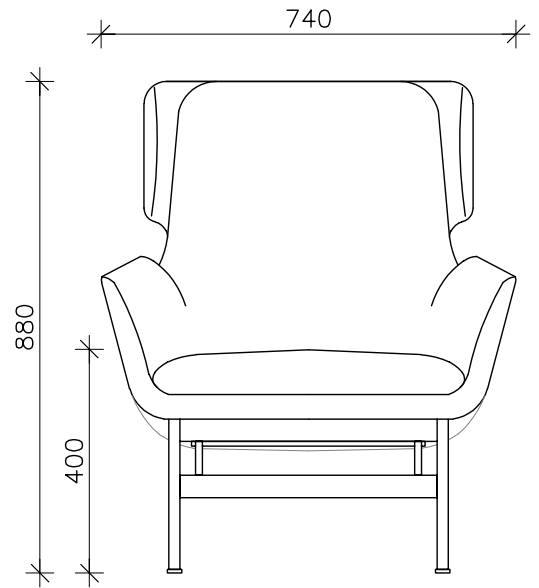
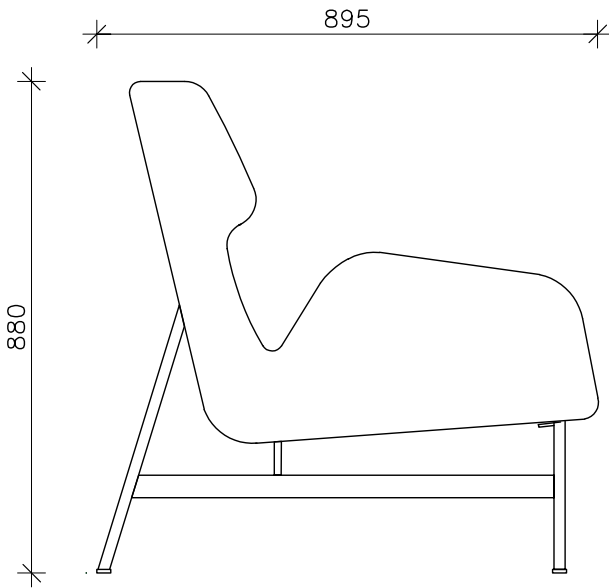

Black

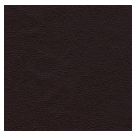

Mocca

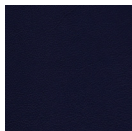

Navy



Straw

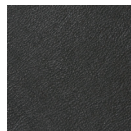

Anthracite



Elephant



Oyster



Latte



White

WOOD OPTIONS



Natural Oak

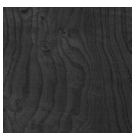

Carbon Oak

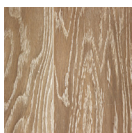

Chalked Oak

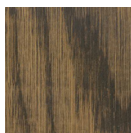

Dark Java Ash



Natural Ash



Carbon Ash



Walnut



Dark Java Oak

DIMENSIONS

740W x 895D x 880H mm - Seat Height: 400 mm

DESCRIPTION

Upholstered dual density foam cushion frame construction with mild Steel Base in Ferrograin powdercoating. Available with a Stainless Steel Base Option.

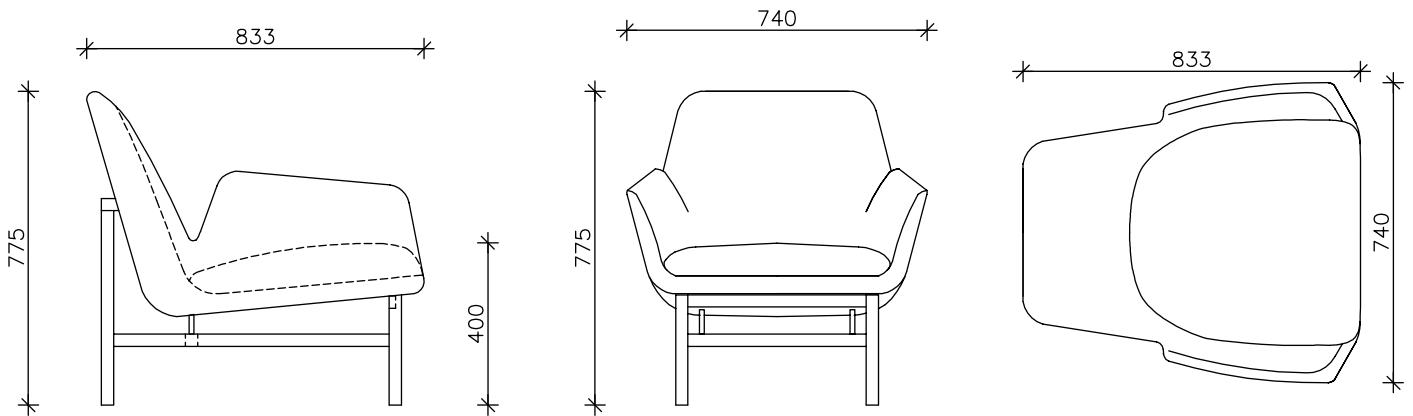

LEATHER OPTIONS | OPTIONAL C.O.M



WOOD OPTIONS



DIMENSIONS

740W x 833D x 775H mm | SEAT HEIGHT 400 mm

DESCRIPTION

Solid wood frame construction, dual density foam cushion.
Base options: ash & oak available in natural, white or carbon stain.
Also available in walnut.

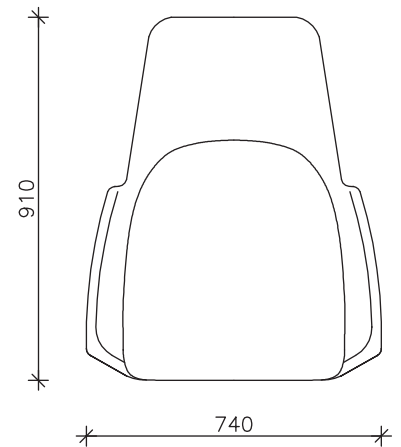
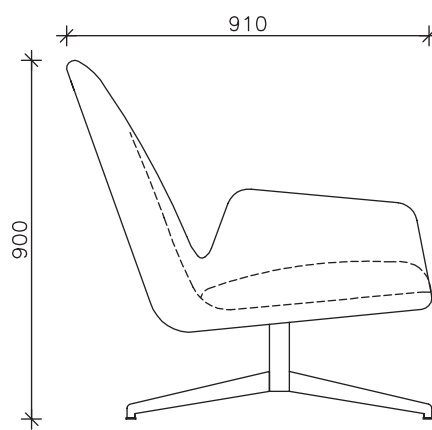
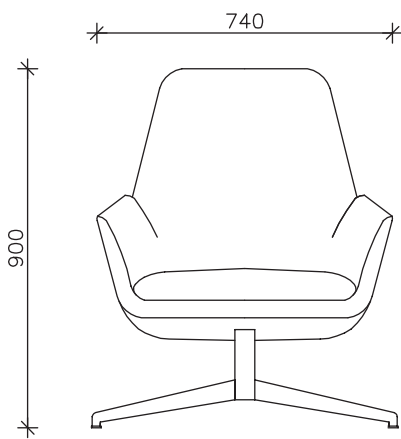

LEATHER OPTIONS | OPTIONAL C.O.M



WOOD OPTIONS



DIMENSIONS

740W x 910D x 900H mm | SEAT HEIGHT 400 mm

DESCRIPTION

Solid wood frame construction, dual density foam cushion.
Base options: black or white powder coated mild steel swivel base
or stainless steel swivel base.

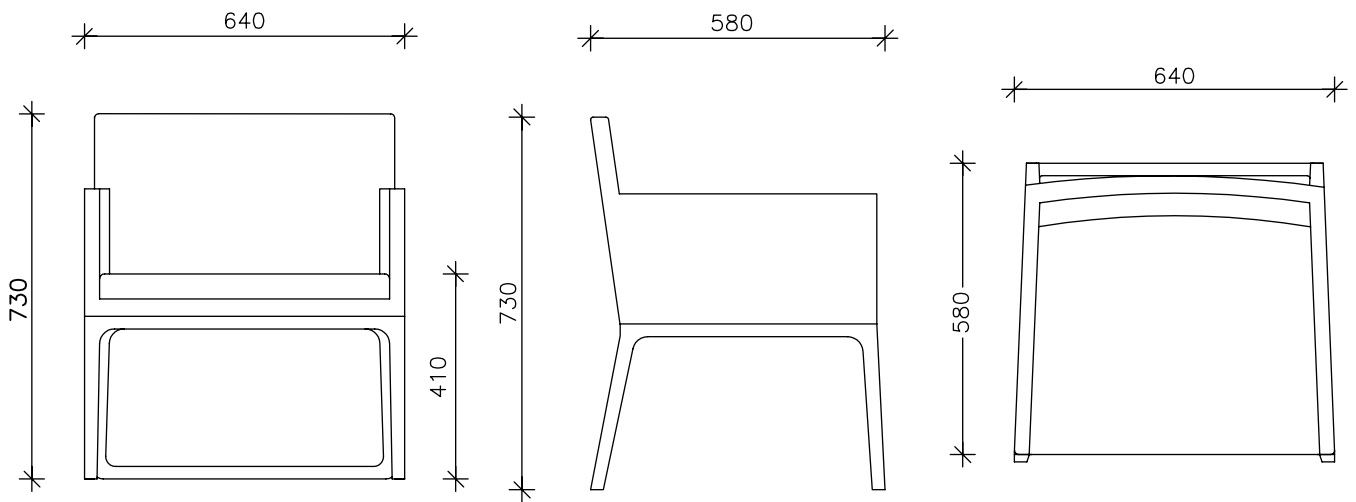

LEATHER OPTIONS | OPTIONAL C.O.M



WOOD OPTIONS



DIMENSIONS

640W x 580D x 730H mm | SEAT HEIGHT 410 mm

DESCRIPTION

Solid wood frame construction, dual density foam cushion, upholstered in leather.

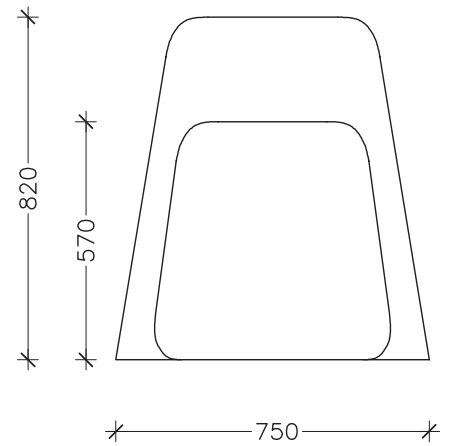
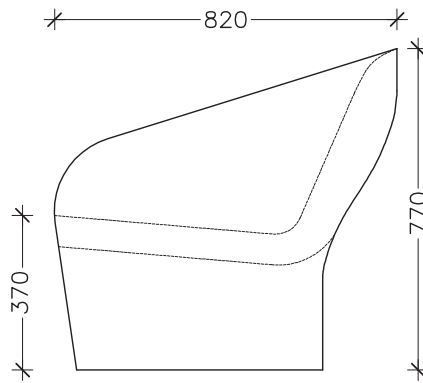
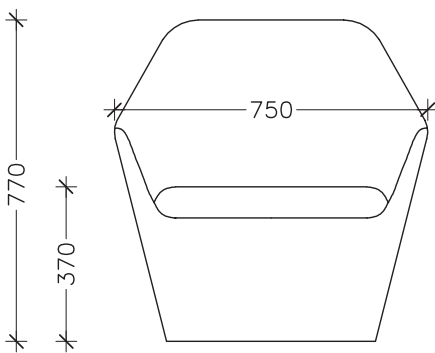

LEATHER OPTIONS | OPTIONAL C.O.M



WOOD OPTIONS



DIMENSIONS

750W x 820D x 770H mm | SEAT HEIGHT 370 mm

DESCRIPTION

Solid wood frame construction, dual density foam cushion with fully upholstered base.

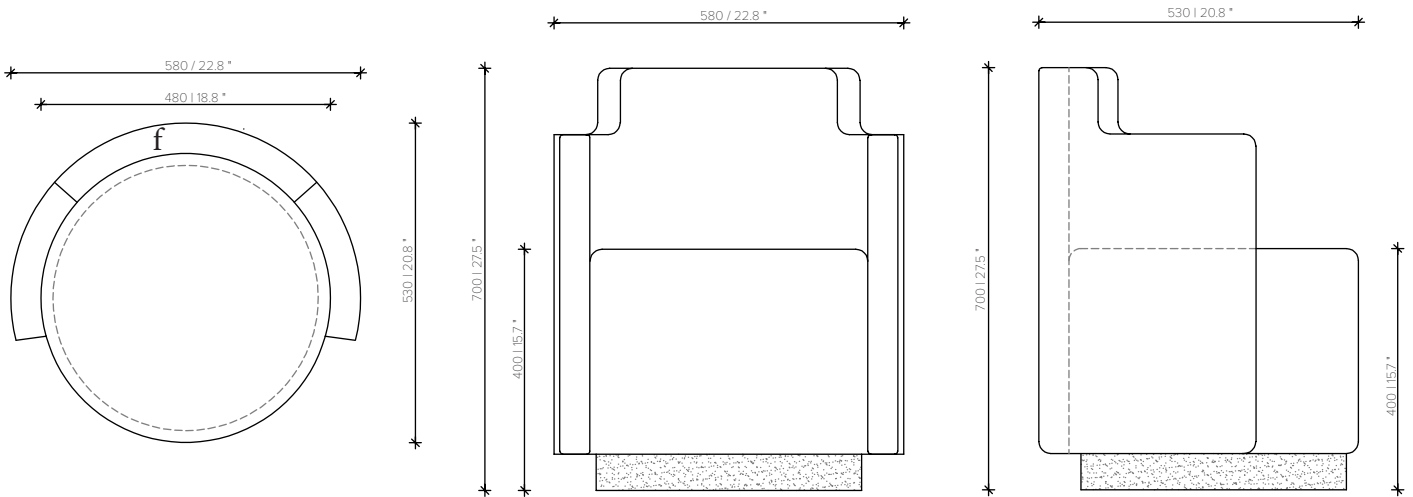

LEATHER OPTIONS | OPTIONAL C.O.M



WOOD OPTIONS



DIMENSIONS

580W x 530D x 700H mm | SEAT HEIGHT 400 mm | 22.8W x 20.8D x 27.5H in | SEAT HEIGHT 15.7 mm

DESCRIPTION

Fully Upholstered Tub Chair with Timber base.
Customer's Own Material Available

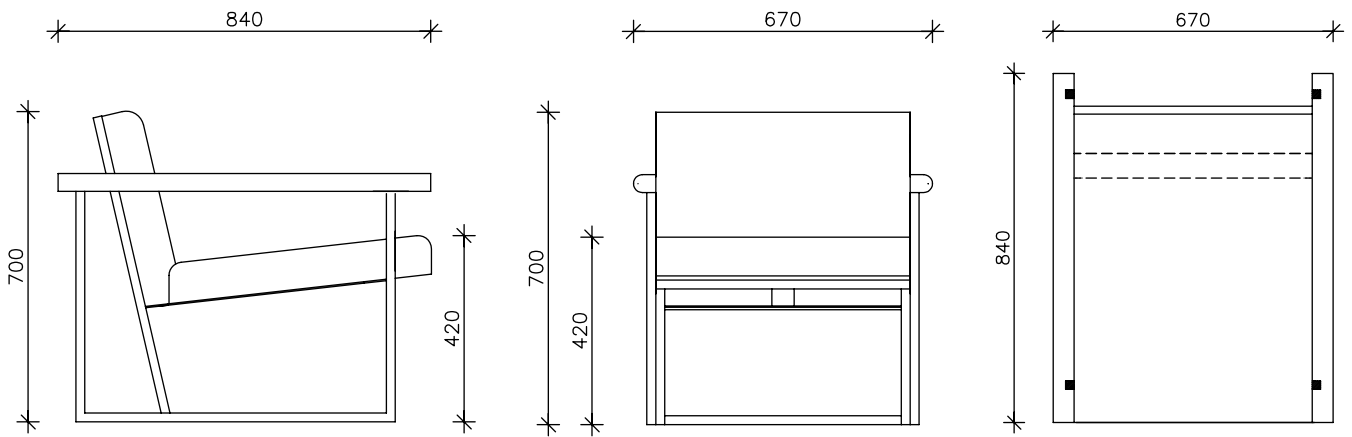

LEATHER OPTIONS | OPTIONAL C.O.M



WOOD OPTIONS



DIMENSIONS

670W x 840D x 700H mm | SEAT HEIGHT 420 mm

DESCRIPTION

Mild steel frame construction in Ferrograin powdercoating with solid timber arms, dual density foam cushion and upholstered in leather.

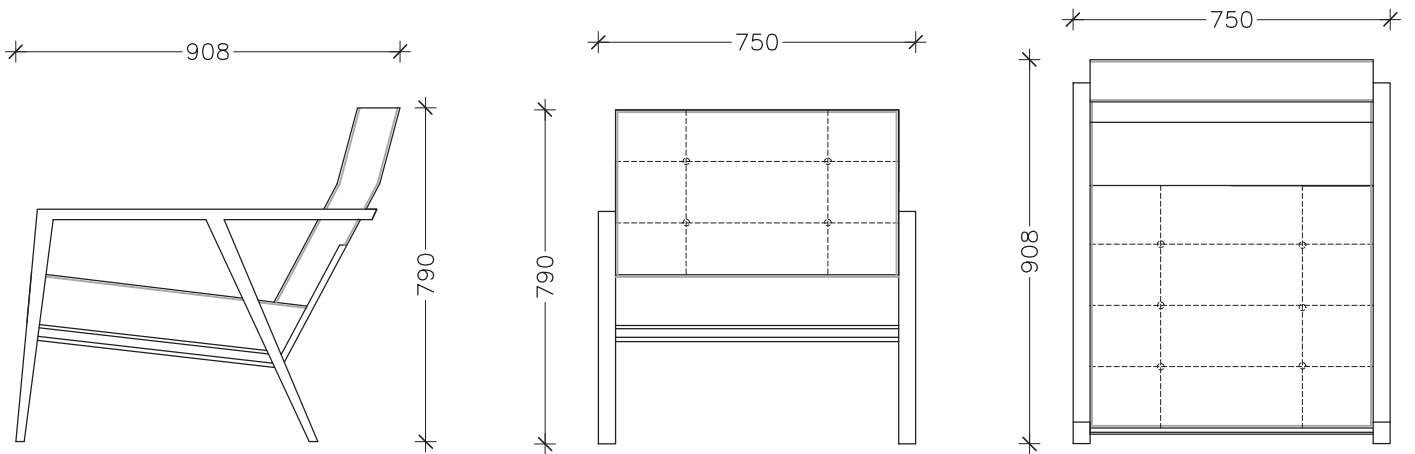

LEATHER OPTIONS | OPTIONAL C.O.M



WOOD OPTIONS



DIMENSIONS

750W x 908D x 790H mm | SEAT HEIGHT 400 mm

DESCRIPTION

Solid wood frame construction, dual density foam cushion.
Base options: ash & oak available in natural, white or carbon stain.
Also available in walnut.

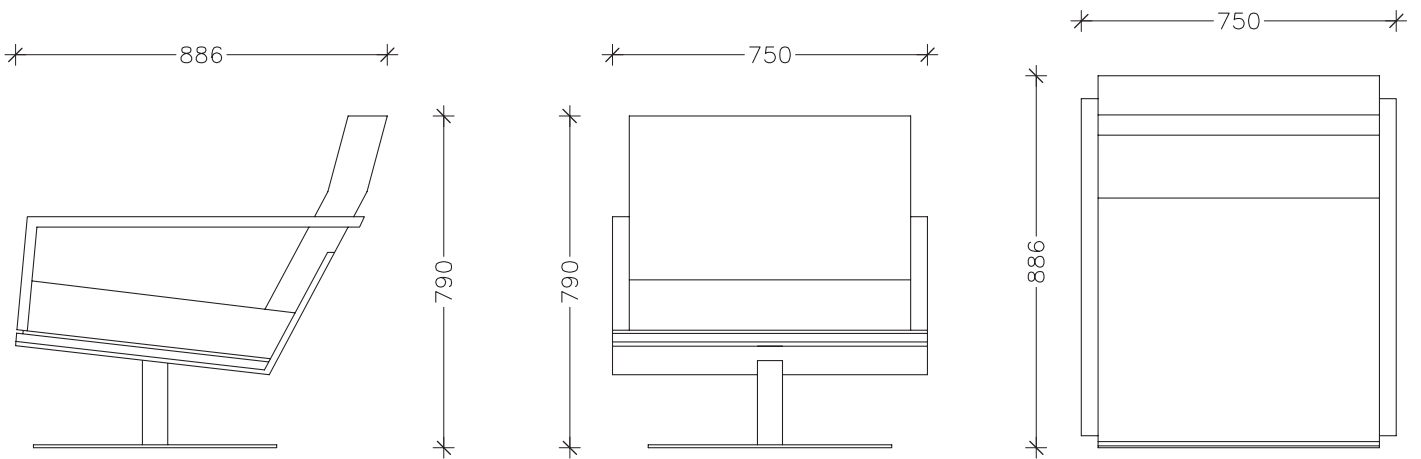

LEATHER OPTIONS | OPTIONAL C.O.M



WOOD OPTIONS



DIMENSIONS

750W x 886D x 790H mm | SEAT HEIGHT 400 mm

DESCRIPTION

Solid wood frame construction, dual density foam cushion.
 Frame options: ash & oak available in natural, white or carbon stain.
 Also available in walnut. Base options: black or white powder coated.

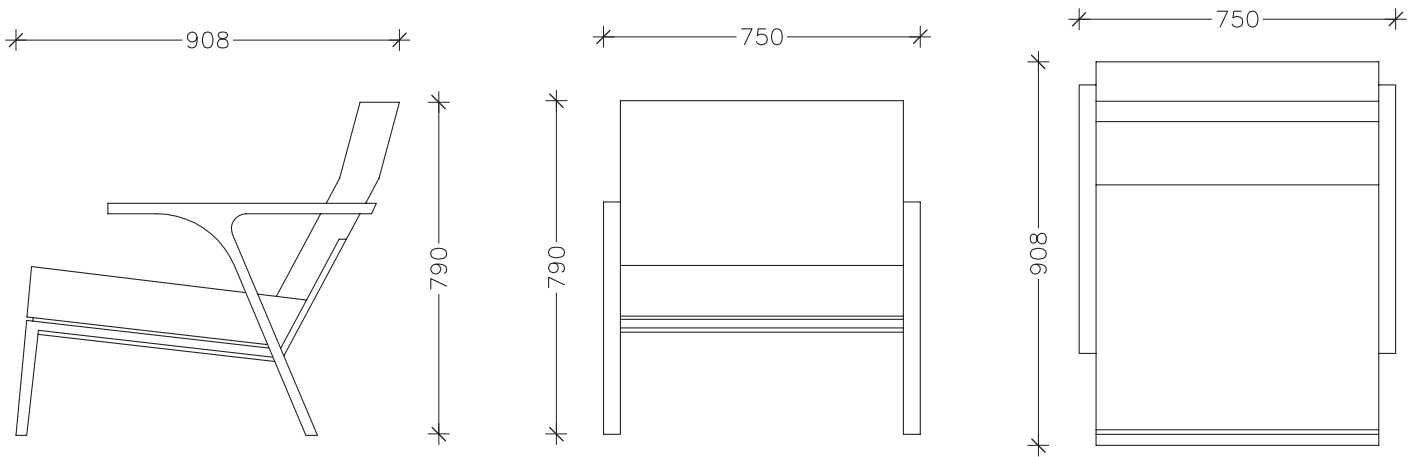

LEATHER OPTIONS | OPTIONAL C.O.M



WOOD OPTIONS



DIMENSIONS

750W x 908D x 790H mm | SEAT HEIGHT 400 mm

DESCRIPTION

Solid wood frame construction, dual density foam cushion.
Base options: ash & oak available in natural, white or carbon stain.
Also available in walnut.

OKHA

STM SWIVEL BASE WISHBONE ARM | Armchair

DESIGNED BY OKHA

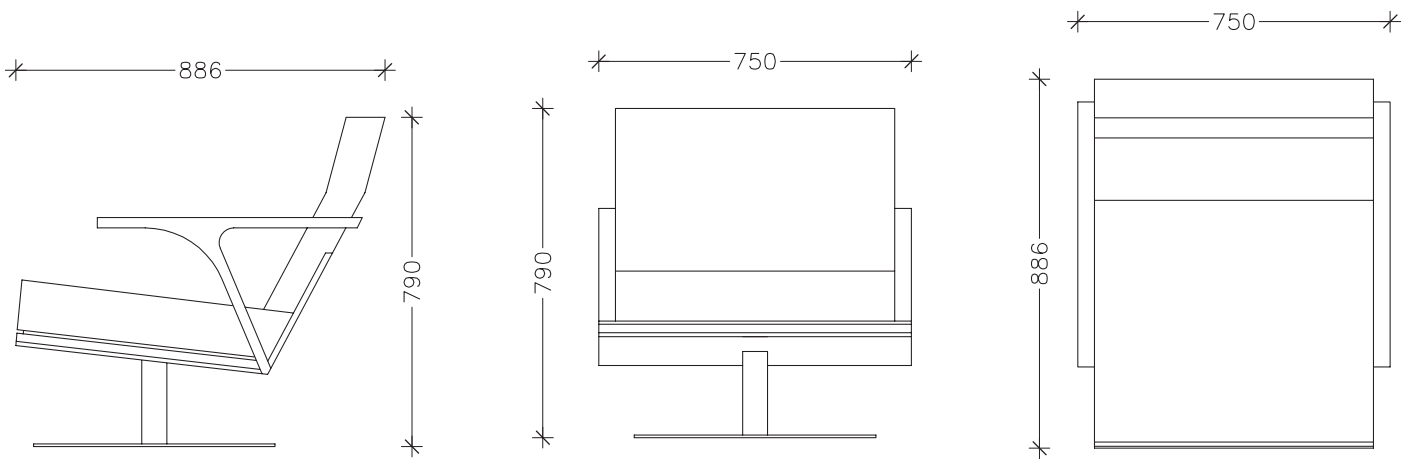

LEATHER OPTIONS | OPTIONAL C.O.M



WOOD OPTIONS



DIMENSIONS

750W x 886D x 790H mm | SEAT HEIGHT 400 mm

DESCRIPTION

Ash and oak frames available in natural, white or carbon stain.
Also available in walnut. Base options: black or white powder coated.

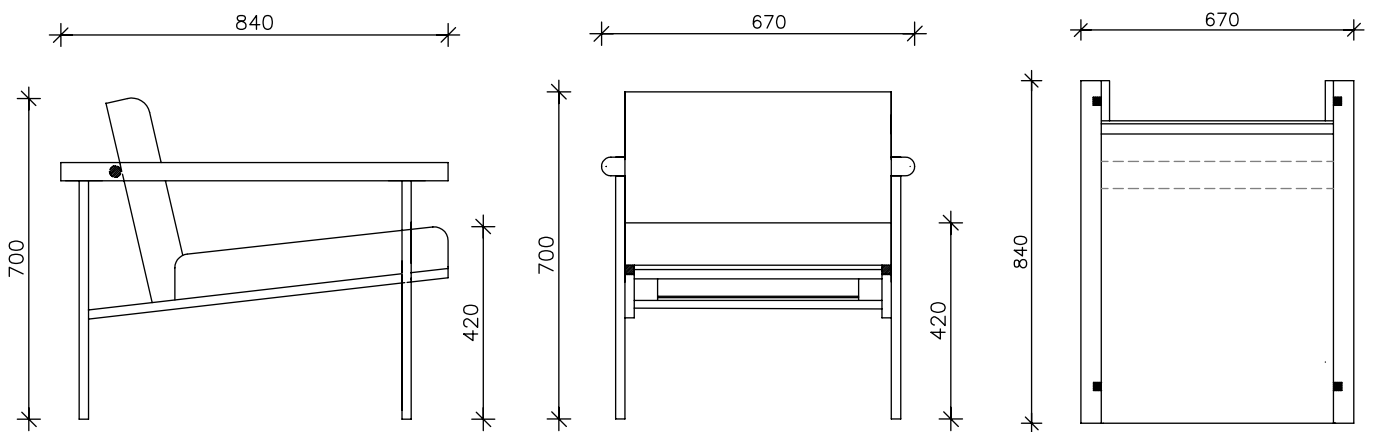

LEATHER OPTIONS | OPTIONAL C.O.M



WOOD OPTIONS



DIMENSIONS

650W x 840D x 700H mm | SEAT HEIGHT 420 mm

DESCRIPTION

Mild steel frame construction in Ferrograin powdercoating with solid timber arms, dual density foam cushion and upholstered in leather.

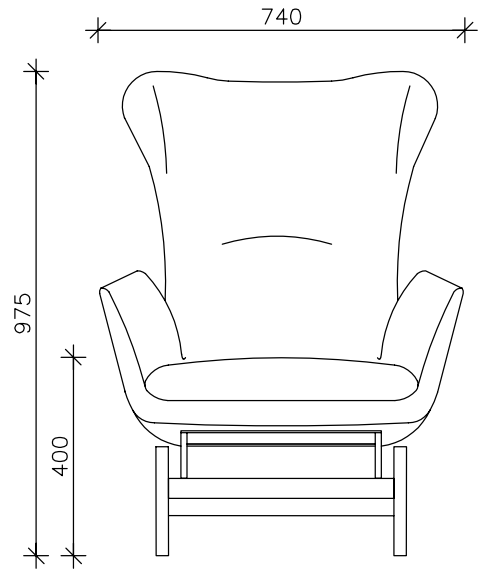
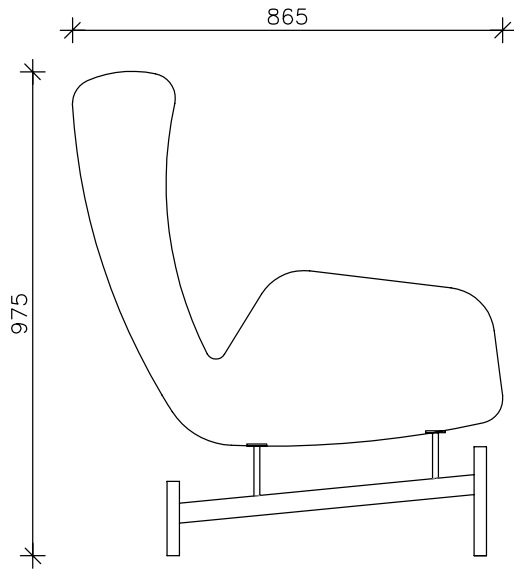

LEATHER OPTIONS | OPTIONAL C.O.M



DIMENSIONS

740w x 865d x 975h (mm) - Seat Height: 400 (mm)

DESCRIPTION

Mild Steel base frame construction in Ferrograin powdercoating, dual density foam cushion and upholstered.

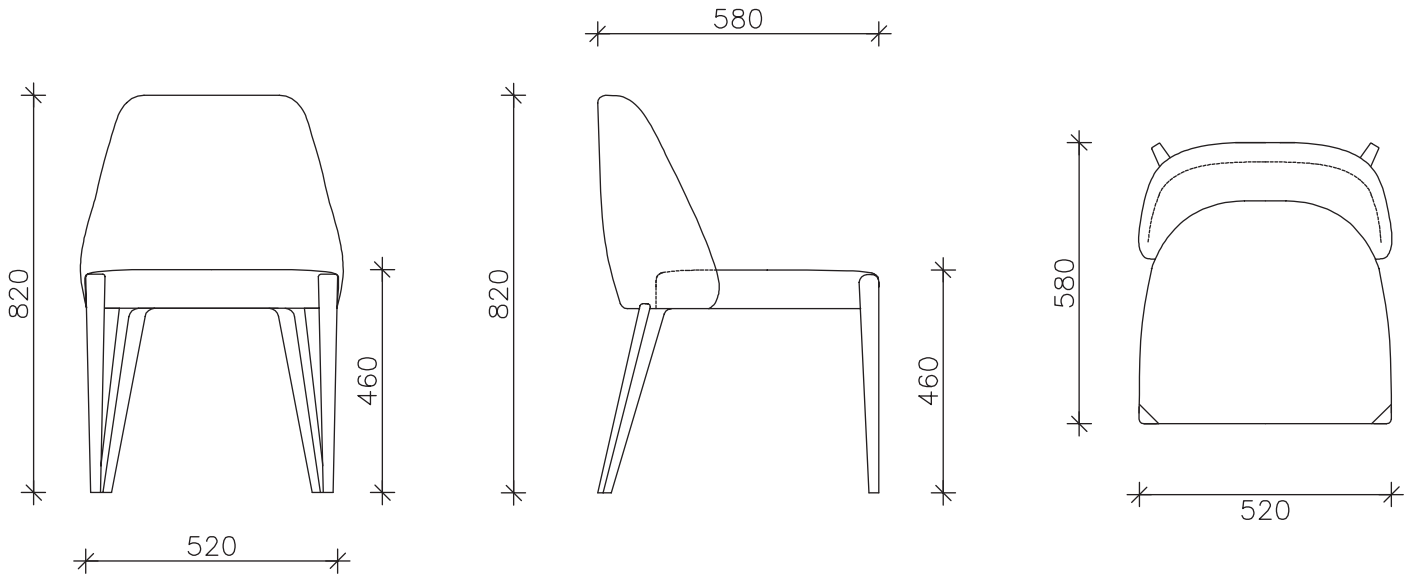

LEATHER OPTIONS | OPTIONAL C.O.M



WOOD OPTIONS



DIMENSIONS

520W x 580D x 820H mm | SEAT HEIGHT 460 mm

DESCRIPTION

Upholstered foam core seat and backrest. Base options: solid ash available in natural, white or carbon stain.

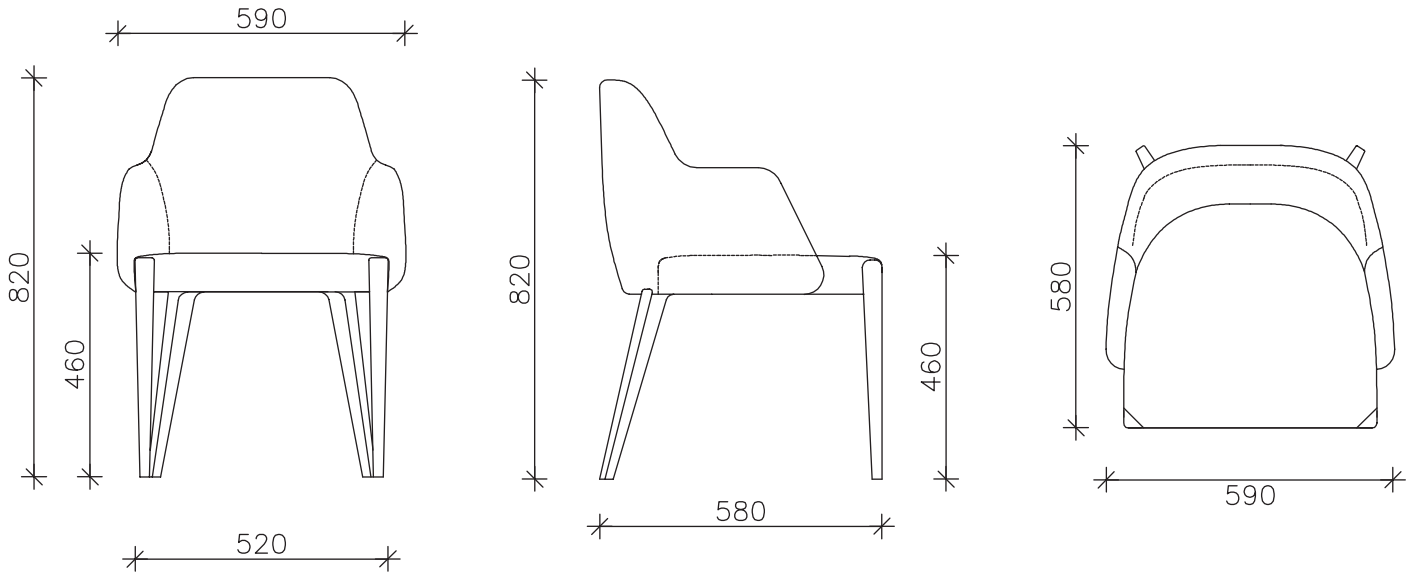

LEATHER OPTIONS | OPTIONAL C.O.M



WOOD OPTIONS



DIMENSIONS

590W x 580D x 820H mm | SEAT HEIGHT 460 mm

DESCRIPTION

Upholstered foam core seat and backrest. Base options: solid ash available in natural, white or carbon stain.

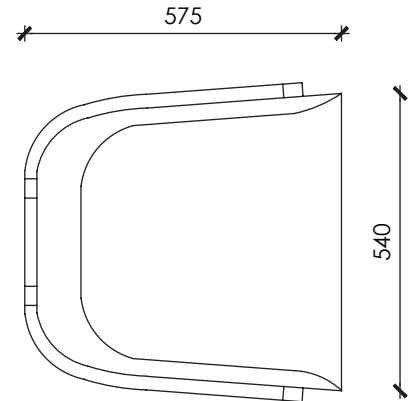
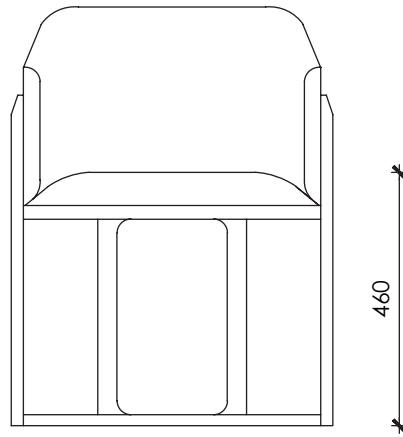
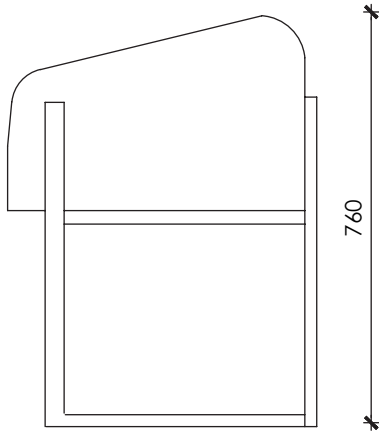

LEATHER OPTIONS | OPTIONAL C.O.M



WOOD OPTIONS



DIMENSIONS

540W x 575D x 760H mm | SEAT HEIGHT 460 mm

DESCRIPTION

Solid oak frame, fully upholstered dual density foam seat.

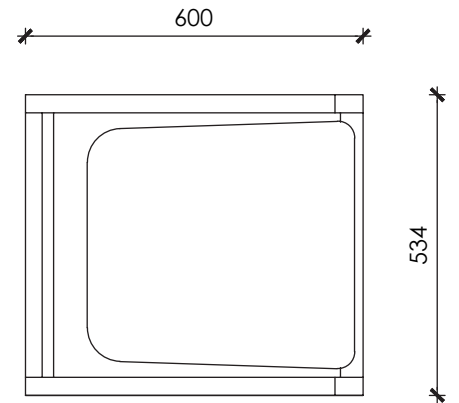
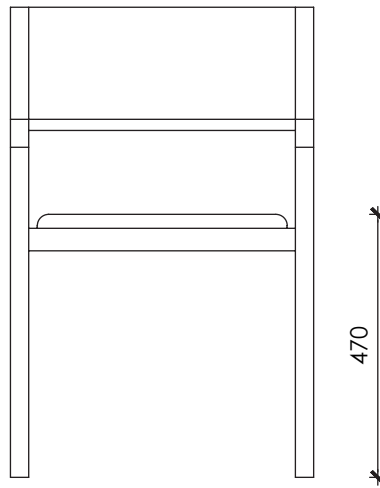
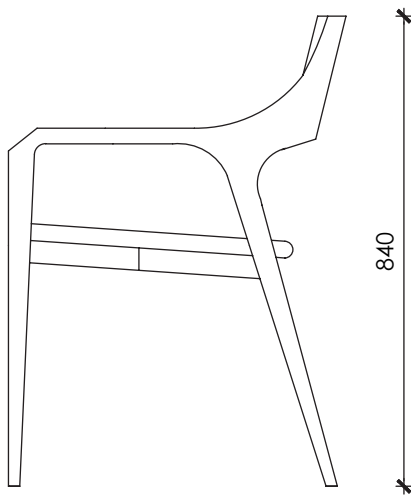

LEATHER OPTIONS | OPTIONAL C.O.M



WOOD OPTIONS



DIMENSIONS

534W x 600D x 840Hmm | SEAT HEIGHT 470 mm

DESCRIPTION

Solid oak frame, fully upholstered dual density foam seat and back.

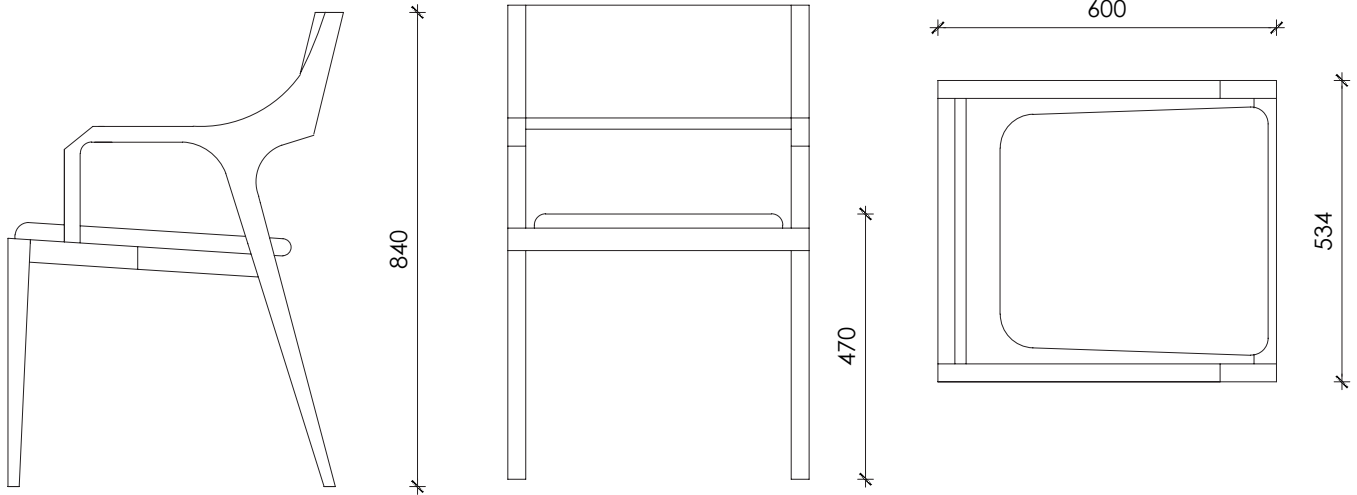

LEATHER OPTIONS | OPTIONAL C.O.M



WOOD OPTIONS



DIMENSIONS

534W x 600D x 840H mm | SEAT HEIGHT 470 mm

DESCRIPTION

Solid oak frame, fully upholstered dual density foam seat and back.

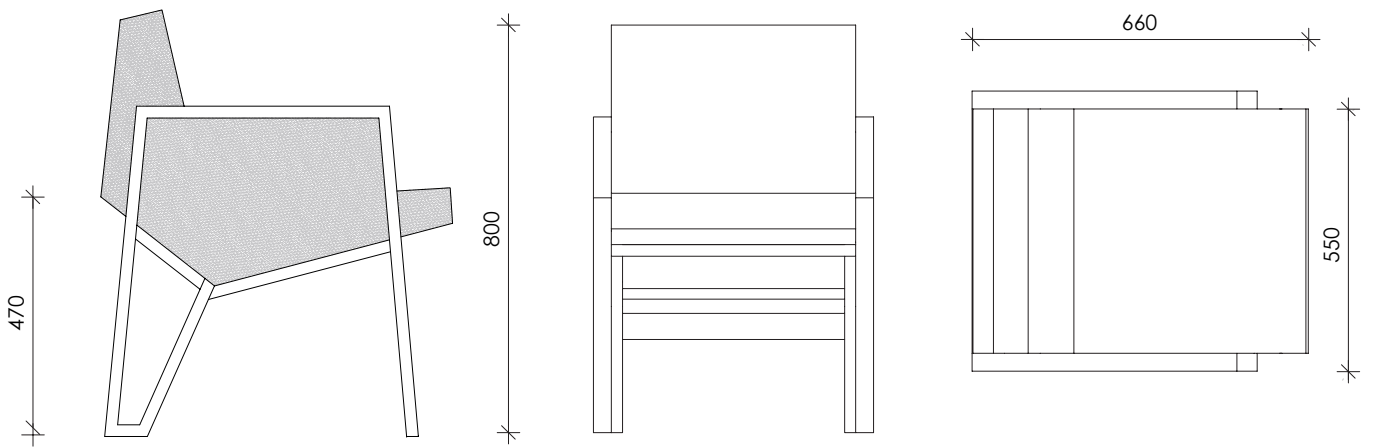

LEATHER OPTIONS | OPTIONAL C.O.M



WOOD OPTIONS



DIMENSIONS

550W x 660D x 800H mm | SEAT HEIGHT 470 mm

DESCRIPTION

Solid oak frame, fully upholstered dual density foam seat.

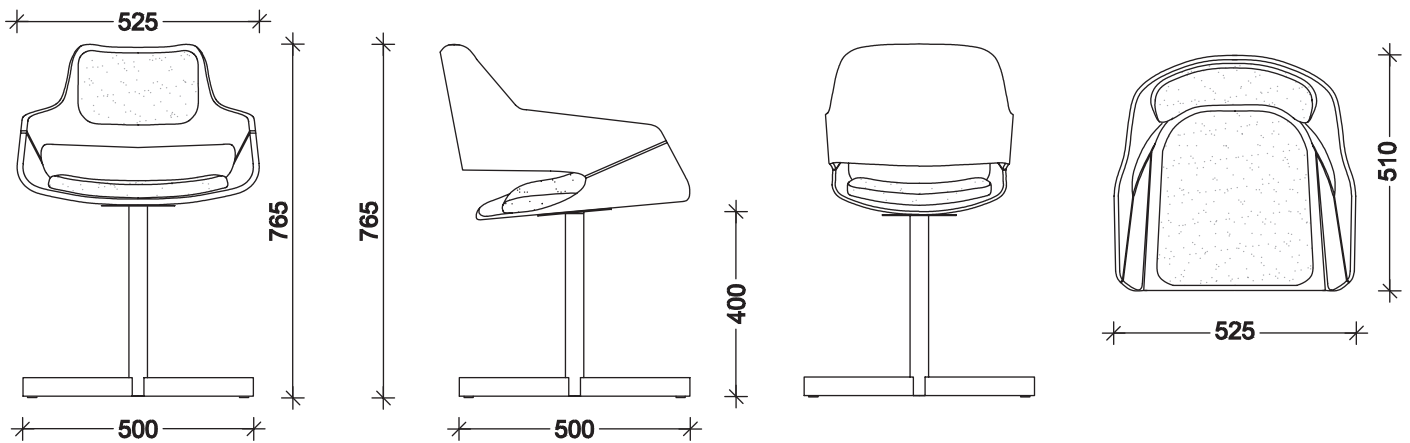

LEATHER OPTIONS | OPTIONAL C.O.M



WOOD OPTIONS



DIMENSIONS

525W x 510D x 765H mm | SEAT HEIGHT 400 mm

DESCRIPTION

Duco finish plywood shell with high density foam seat & back inserts.
Base options: black or white powder coated or mirror polished stainless steel.

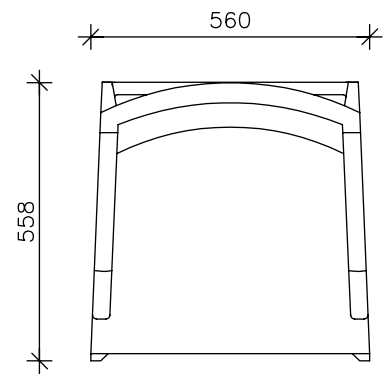
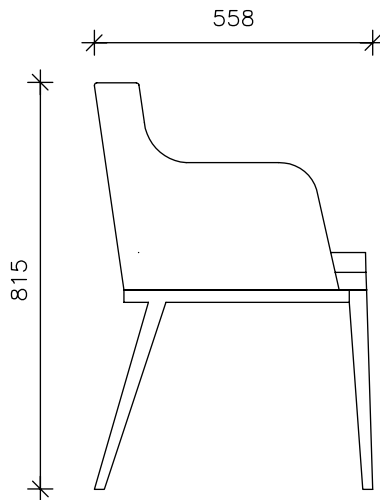
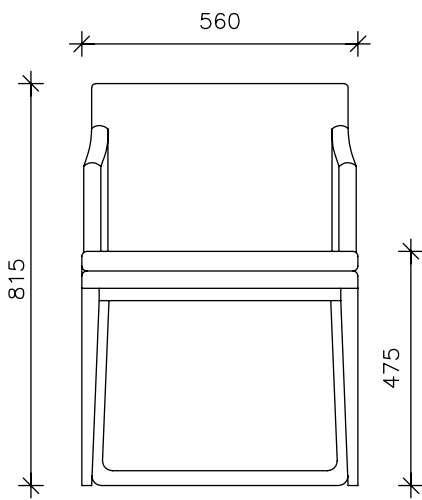

LEATHER OPTIONS | OPTIONAL C.O.M



WOOD OPTIONS



DIMENSIONS

560W x 558D x 815H mm | SEAT HEIGHT 475 mm

DESCRIPTION

Solid wood frame construction, dual density foam cushion, upholstered in leather.

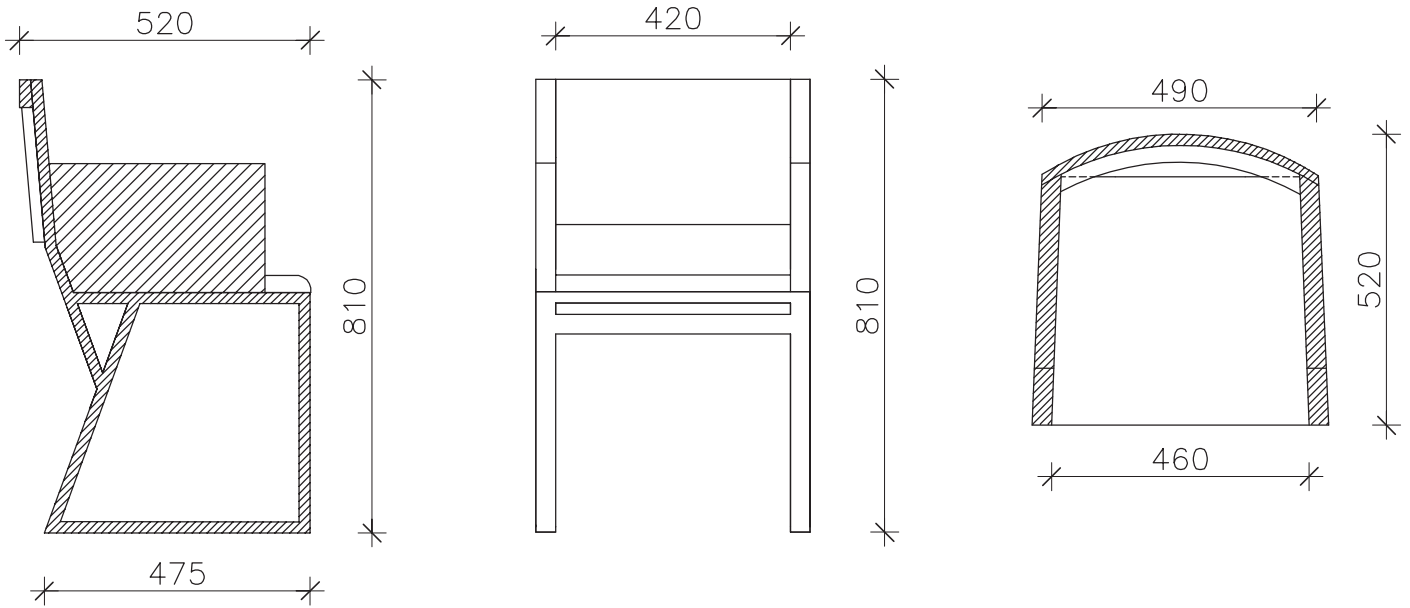

LEATHER OPTIONS | OPTIONAL C.O.M



WOOD OPTIONS



DIMENSIONS

555W x 555D x 810H mm | SEAT HEIGHT 470 mm

DESCRIPTION

Solid oak frame, upholstered high density foam seat and back.
 Frame options: solid oak available in natural, white or carbon stain.

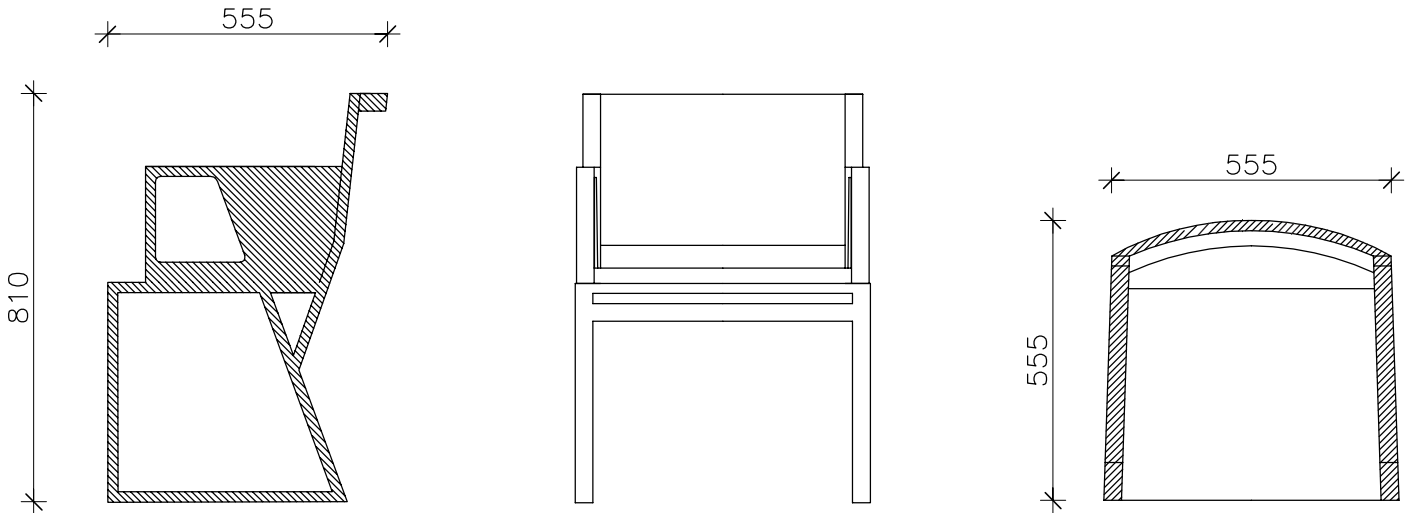

LEATHER OPTIONS | OPTIONAL C.O.M



WOOD OPTIONS



DIMENSIONS

555W x 555D x 810H mm | SEAT HEIGHT 470 mm

DESCRIPTION

Solid oak frame, upholstered high density foam seat and back.
Frame options: solid oak available in natural, white or carbon stain.

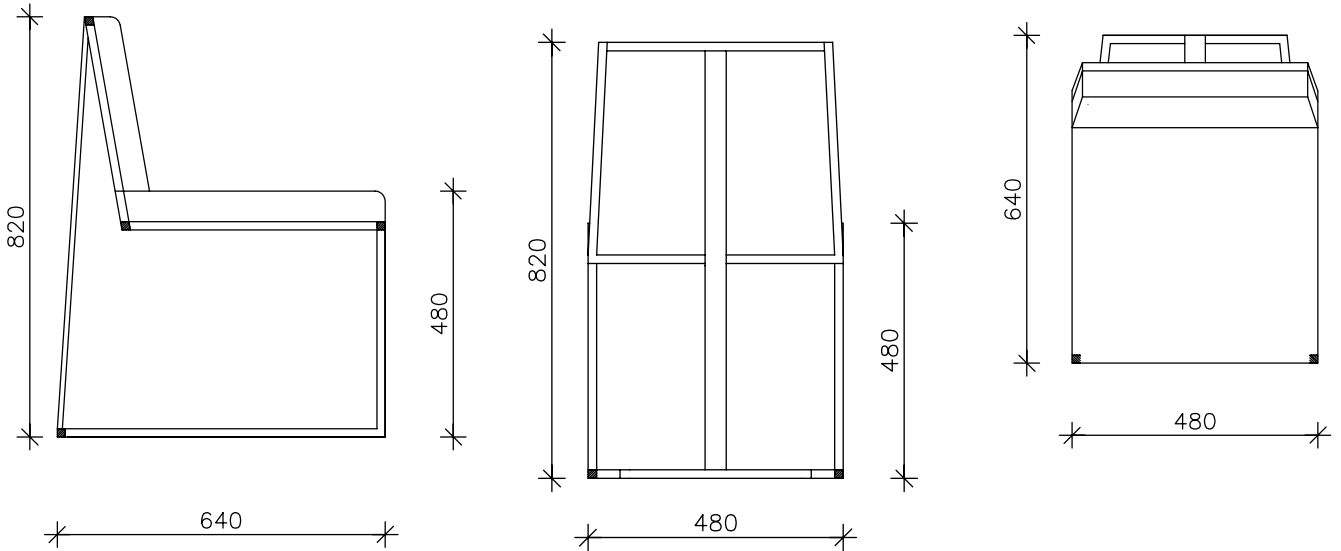

LEATHER OPTIONS | OPTIONAL C.O.M



WOOD OPTIONS



DIMENSIONS

480W x 640D x 820H mm | SEAT HEIGHT 480 mm

DESCRIPTION

Mild Steel base frame construction in Ferrograin powdercoating, upholstered dual density foam cushion.

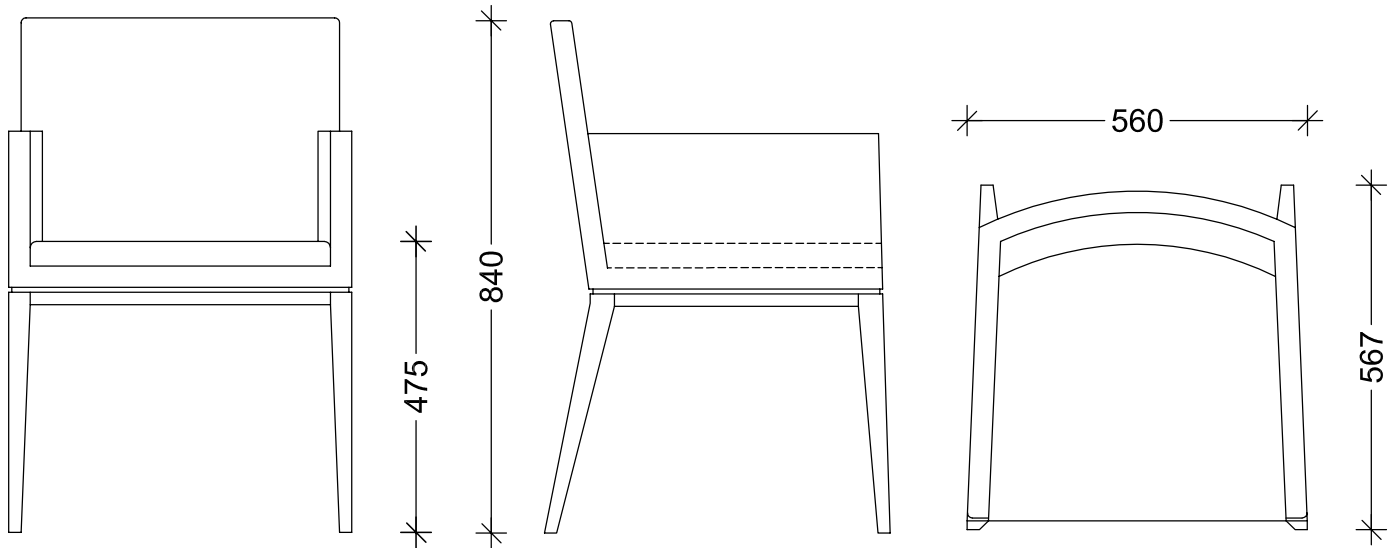

LEATHER OPTIONS | OPTIONAL C.O.M



WOOD OPTIONS



DIMENSIONS

560W x 567D x 840H mm | SEAT HEIGHT 475mm

DESCRIPTION

Solid wood frame construction, foam core cushion. Base options: ash or oak available in natural, white or carbon stain. Also available in walnut.

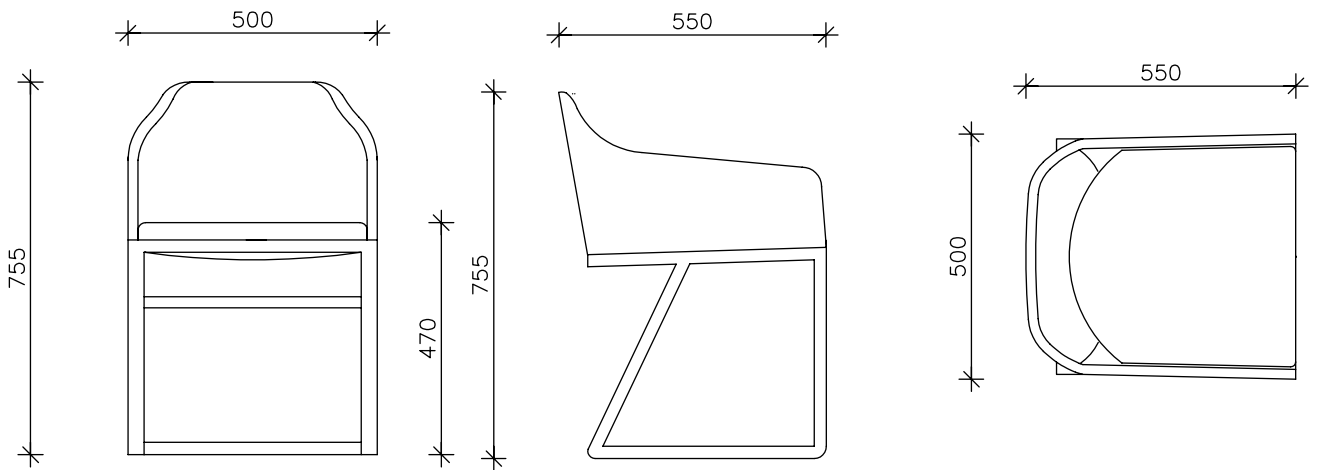

LEATHER OPTIONS | OPTIONAL C.O.M



WOOD OPTIONS



DIMENSIONS

500W x 550D x 755H mm | SEAT HEIGHT 470 mm

DESCRIPTION

Solid wood frame construction, dual density foam cushion, short arm, upholstered in leather.

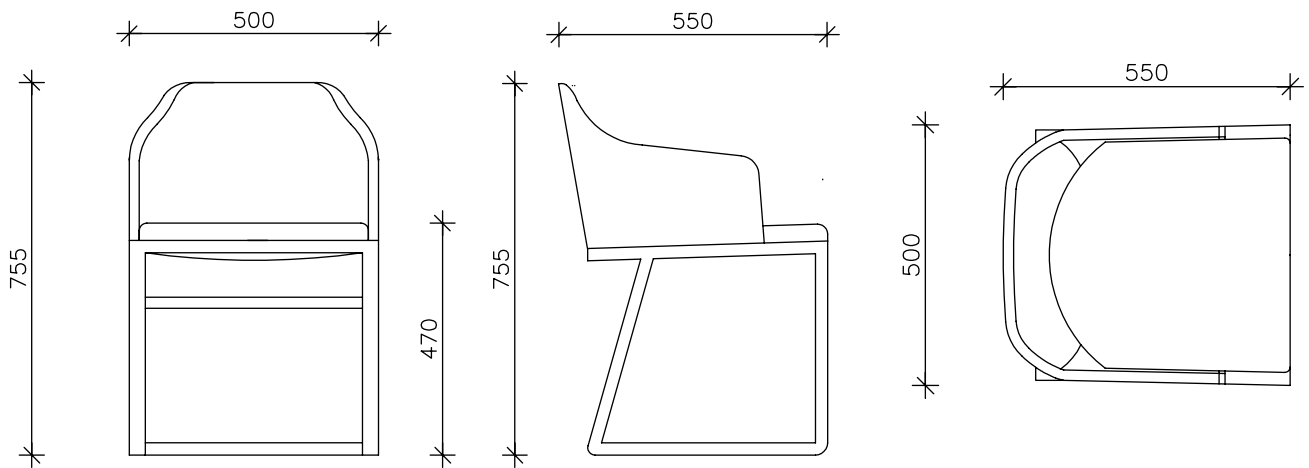

LEATHER OPTIONS | OPTIONAL C.O.M



WOOD OPTIONS



DIMENSIONS

500W x 550D x 755H mm | SEAT HEIGHT 470 mm

DESCRIPTION

Solid wood frame construction, dual density foam cushion, full arm, upholstered in leather.

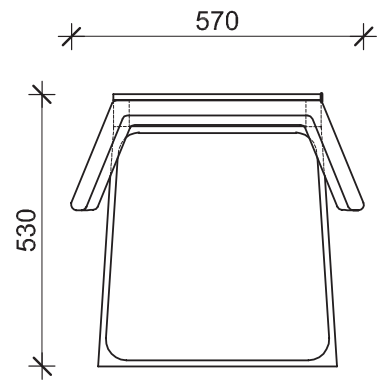
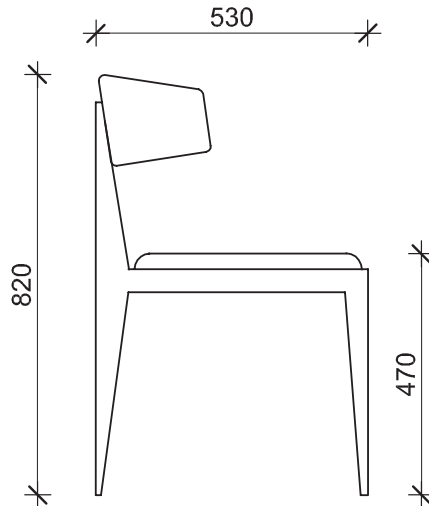
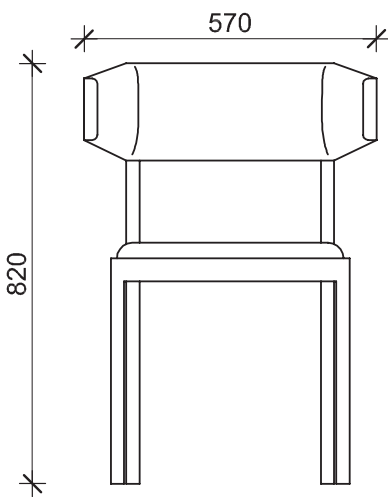

LEATHER OPTIONS | OPTIONAL C.O.M



WOOD OPTIONS



DIMENSIONS

570W x 530D x 820H mm | SEAT HEIGHT 470 mm

DESCRIPTION

Upholstered foam core seat and backrest.

Base options: solid ash available in natural, white or carbon stain.

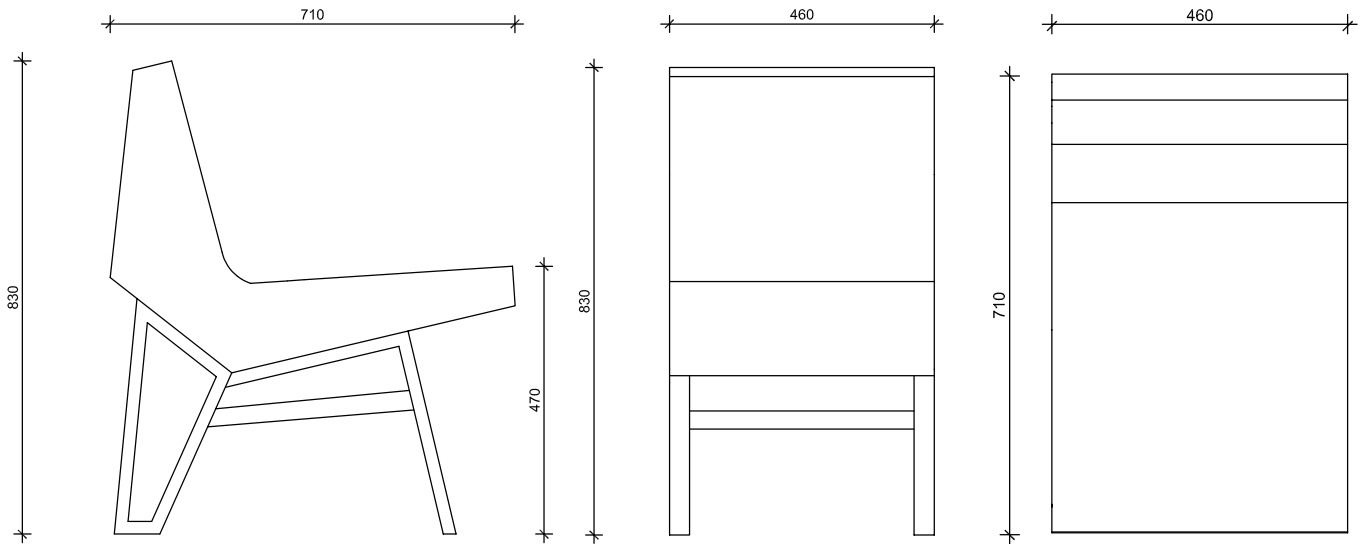

LEATHER OPTIONS | OPTIONAL C.O.M



WOOD OPTIONS



DIMENSIONS

460W x 710D x 830H mm | SEAT HEIGHT 470 mm

DESCRIPTION

Solid oak frame, fully upholstered dual density foam seat.

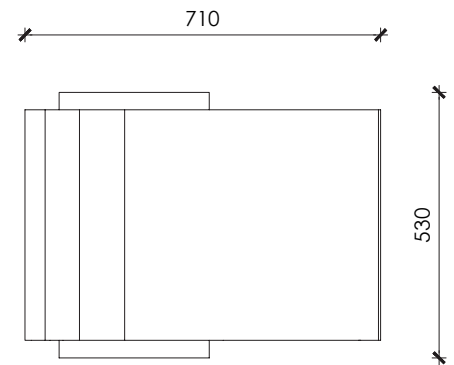
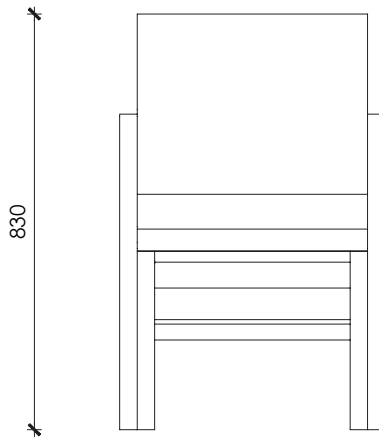
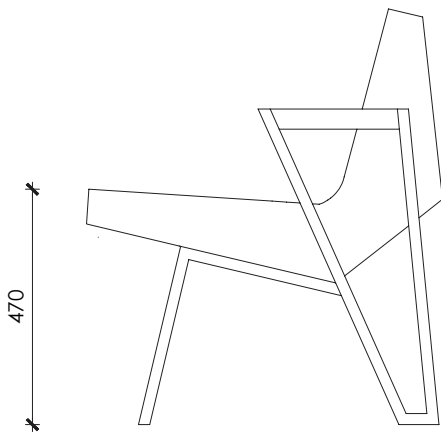

LEATHER OPTIONS | OPTIONAL C.O.M



WOOD OPTIONS



DIMENSIONS

530W x 710D x 830H mm | SEAT HEIGHT 470 mm

DESCRIPTION

Solid oak frame, fully upholstered dual density foam seat.

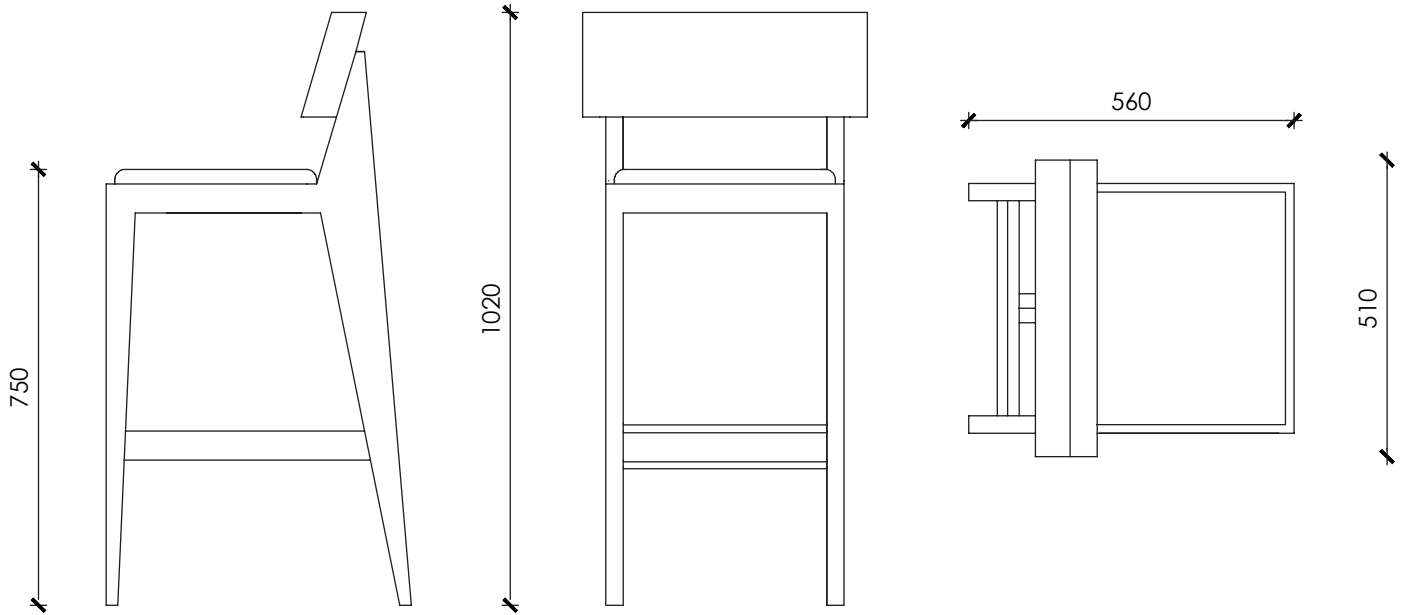

LEATHER OPTIONS | OPTIONAL C.O.M



WOOD OPTIONS



DIMENSIONS

510W x 560D x 1020H mm | SEAT HEIGHT 750 mm

DESCRIPTION

Solid oak frame, fully upholstered seat and back.

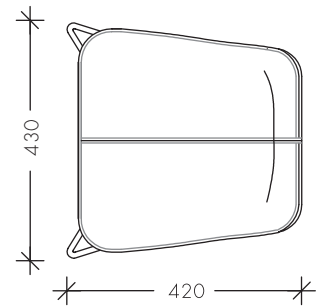
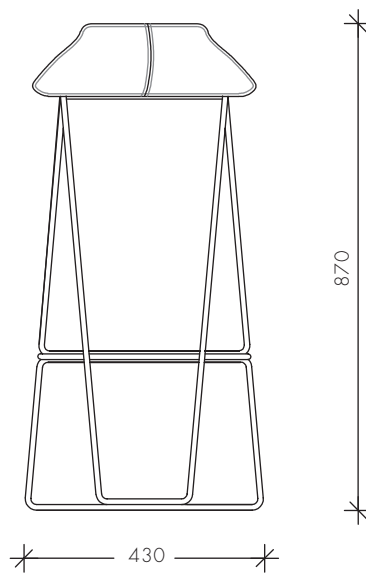
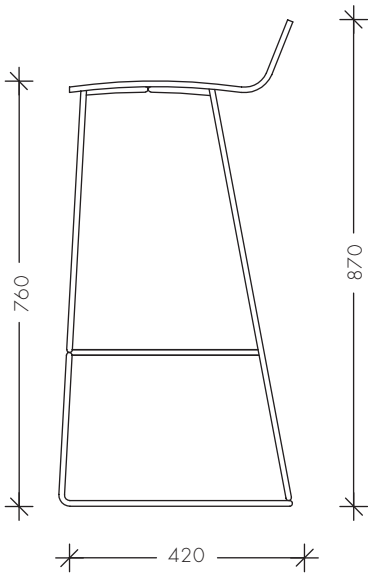

LEATHER OPTIONS | OPTIONAL C.O.M



DIMENSIONS

430W x 420D x 870H mm | SEAT HEIGHT 760 mm

DESCRIPTION

Black or white powder coated mild steel frame with upholstered plywood seat.

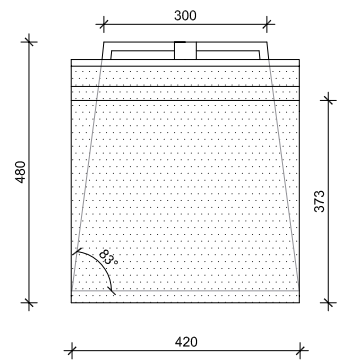
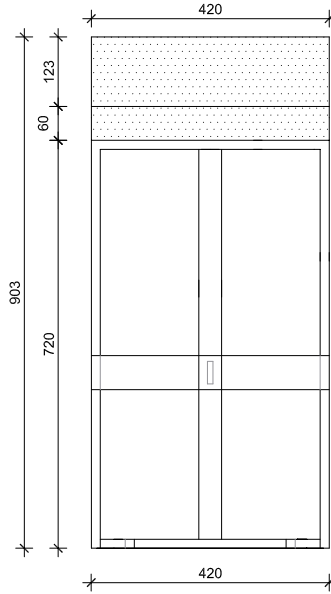
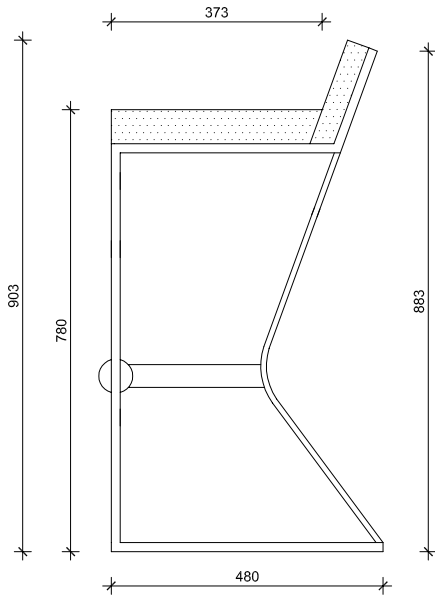

LEATHER OPTIONS | COM AVAILABLE



Black

Anthracite

Straw

Elephant

Latte

Mocca

Navy

Oyster

White

DIMENSIONS

420W x 480D x 903H mm | SEAT HEIGHT 780 mm

WEIGHT

15 kg unboxed

DESCRIPTION

Matt powder coated mild steel frame, fully upholstered dual density foam seat.

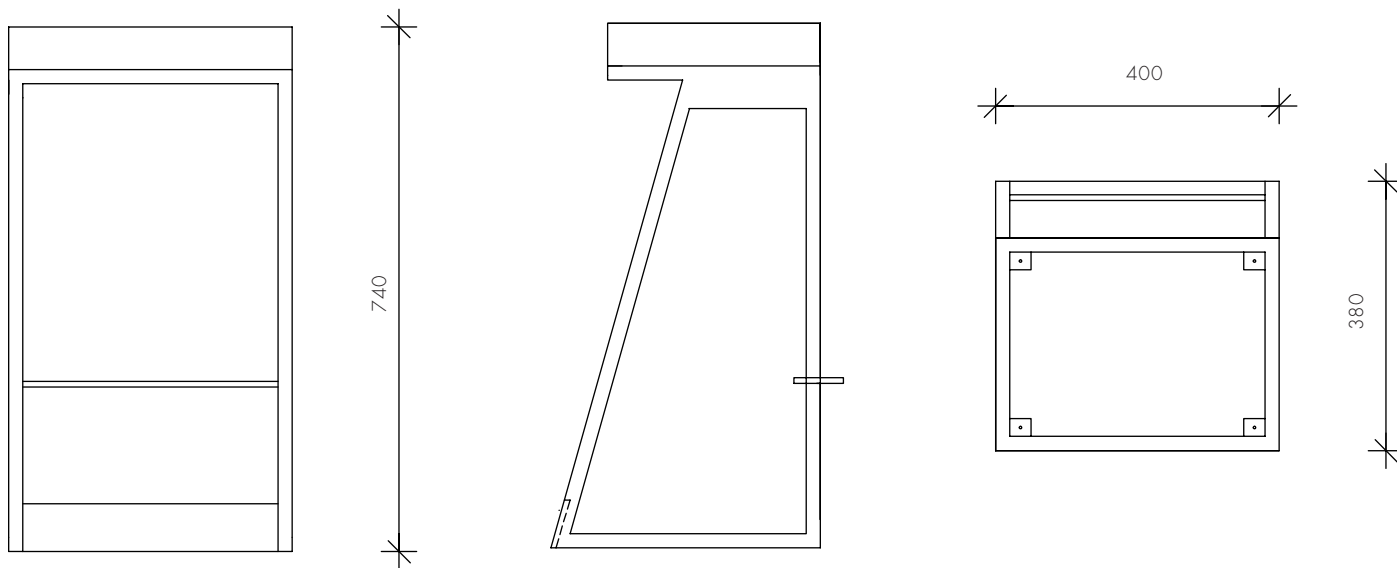

LEATHER OPTIONS | OPTIONAL C.O.M



DIMENSIONS

400W x 380D x 740H mm | SEAT HEIGHT 740 mm

DESCRIPTION

Upholstered foam core seat. Base options: black or white powder coated or mirror polished stainless steel.

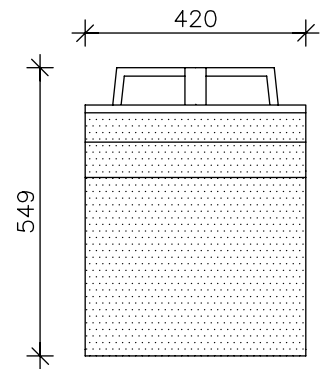
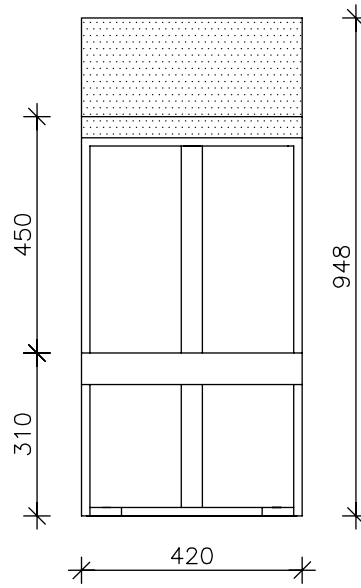
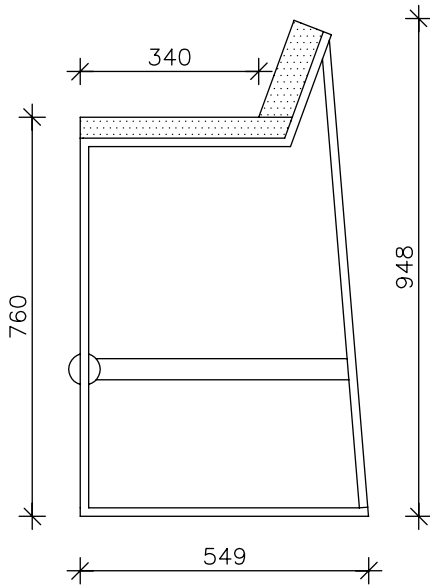

LEATHER OPTIONS | OPTIONAL C.O.M



DIMENSIONS

420W x 549D x 948H mm | SEAT HEIGHT 760 mm

DESCRIPTION

Matt powder coated mild steel frame, fully upholstered dual density foam seat.

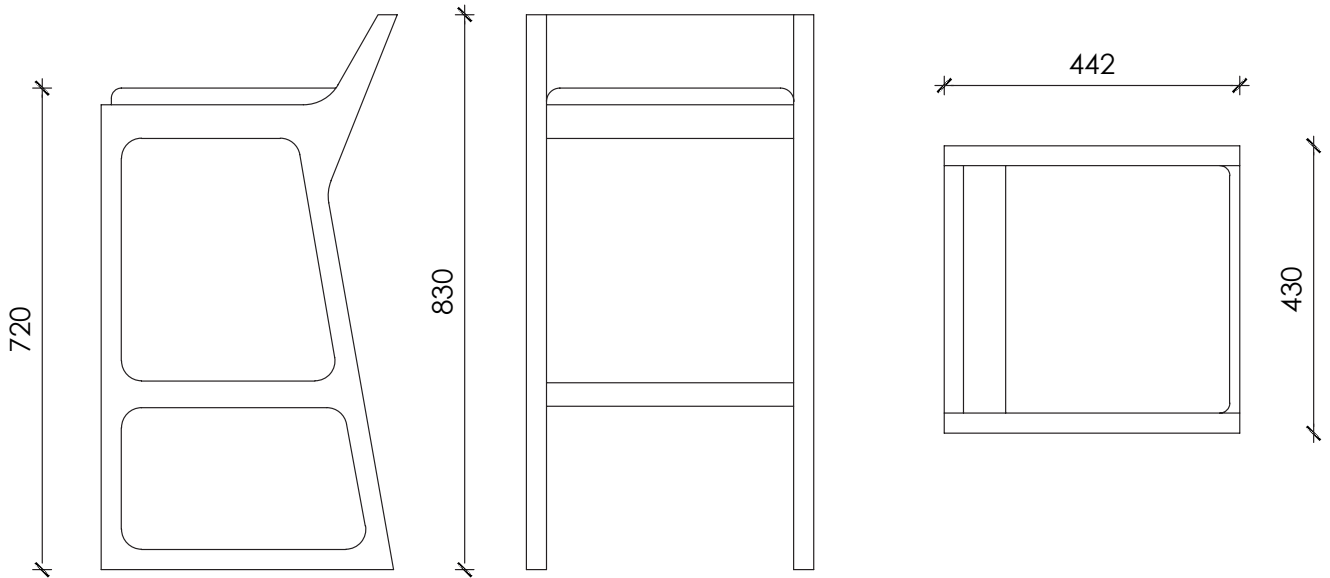

LEATHER OPTIONS | OPTIONAL C.O.M

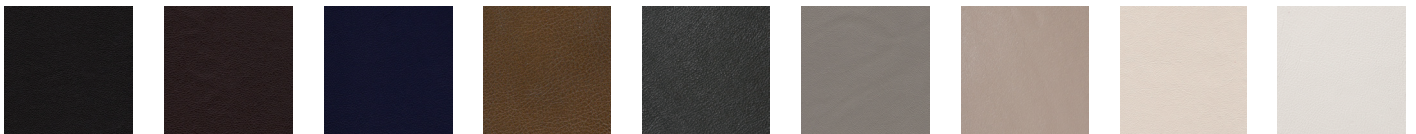

Black

Mocca

Navy

Straw

Anthracite

Elephant

Oyster

Latte

White

DIMENSIONS

430W x 442D x 830H mm | SEAT HEIGHT 720 mm

DESCRIPTION

Solid oak frame, fully upholstered dual density foam seat and back.

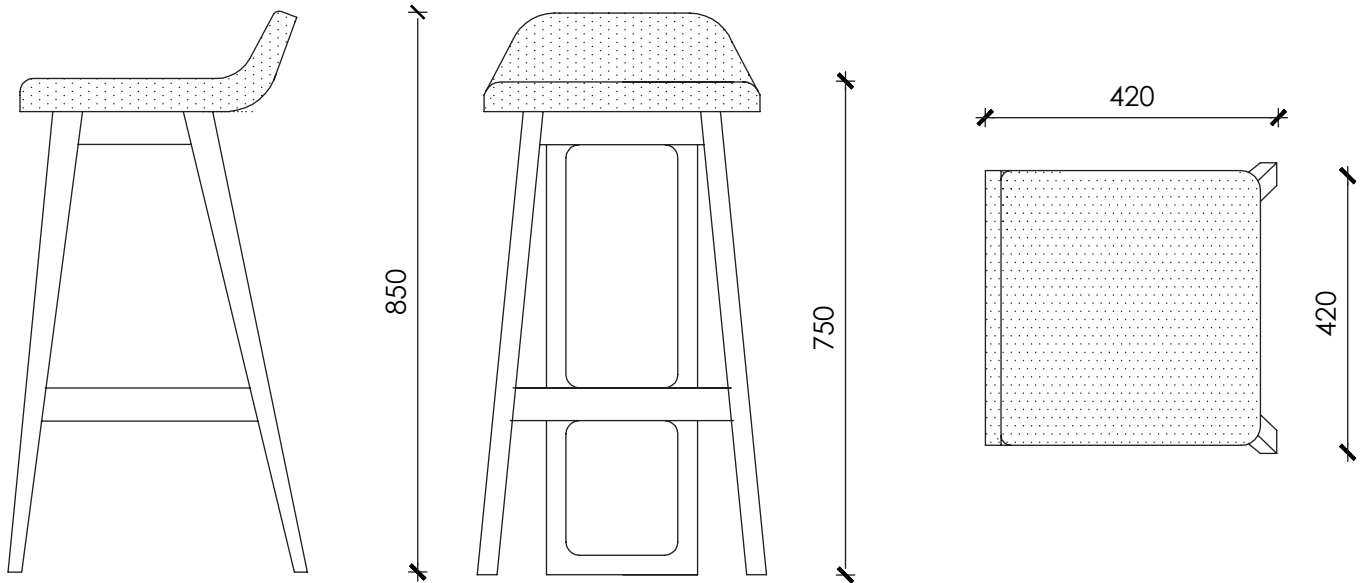

WOOD OPTIONS



DIMENSIONS

420W x 445D x 850H mm | SEAT HEIGHT 750 mm

DESCRIPTION

Solid oak frame, fully upholstered plywood and foam seat.

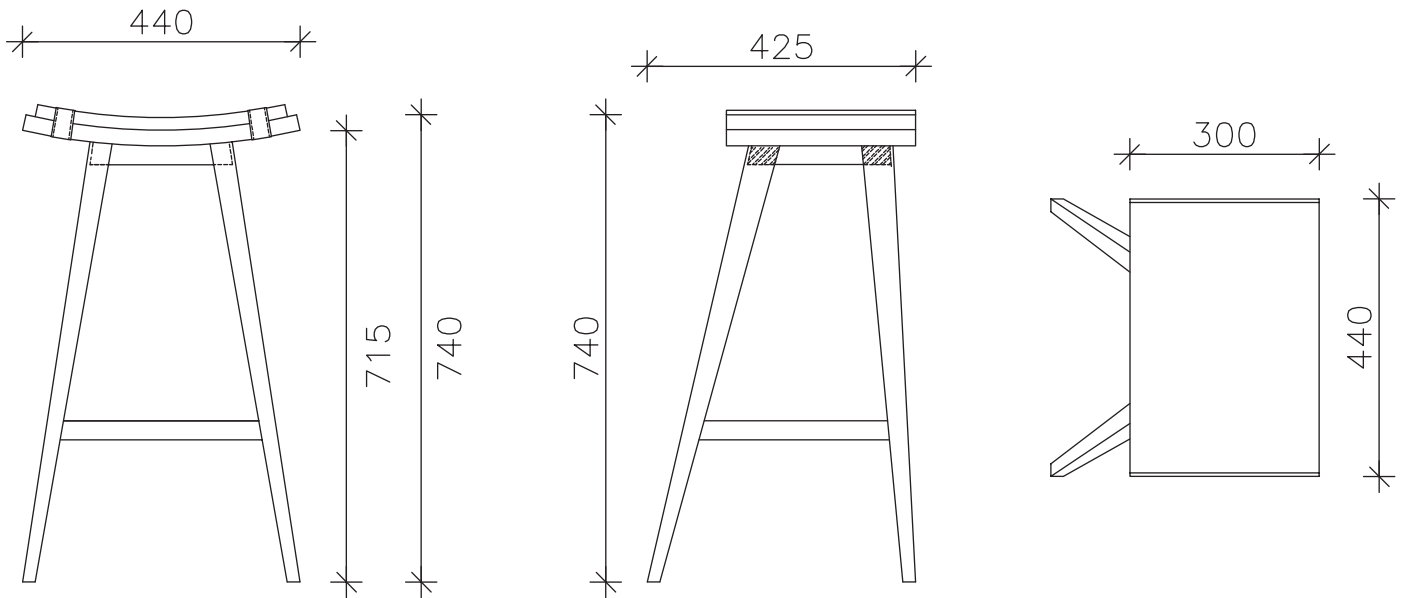

LEATHER OPTIONS | OPTIONAL C.O.M



WOOD OPTIONS



DIMENSIONS

440W x 425D x 740H mm | SEAT HEIGHT 715mm

DESCRIPTION

Solid oak frame, upholstered seat cushion. Frame options: solid oak available in natural, white or carbon stain.

DESIGNED BY OKHA

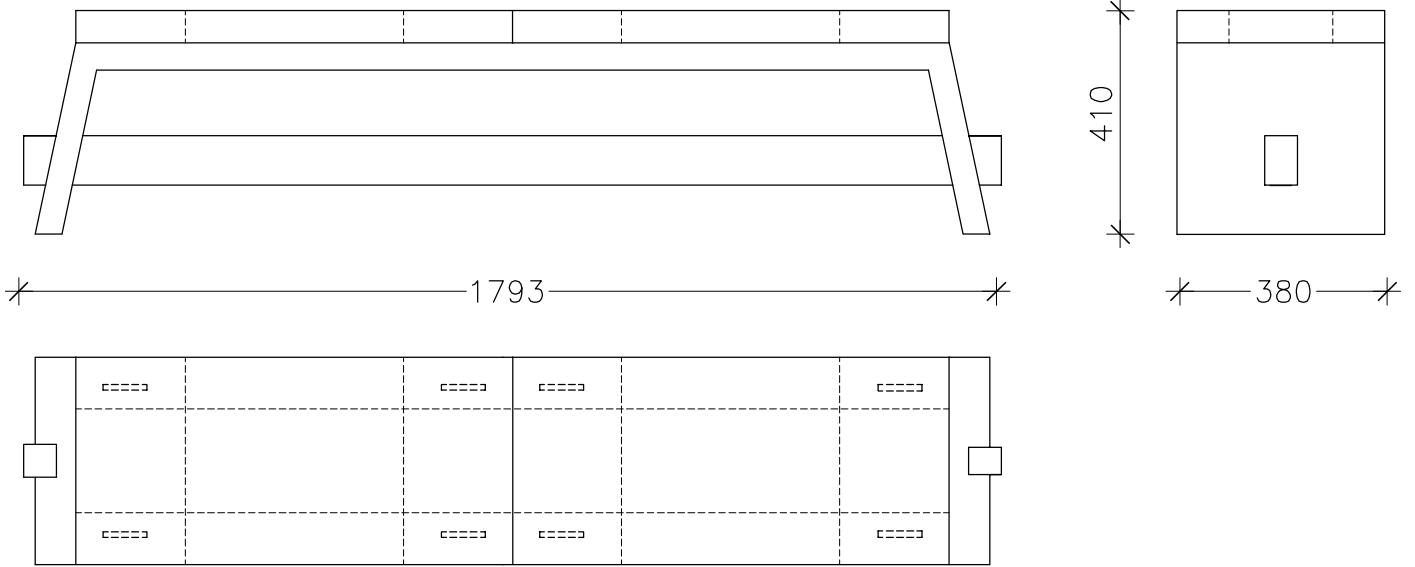

LEATHER OPTIONS | OPTIONAL C.O.M



WOOD OPTIONS



DIMENSIONS

1793W x 380D x 410H mm | SEAT HEIGHT: 410 mm

DESCRIPTION

Upholstered solid wood frame with dual density foam core.
Frame options: natural or carbon stained oak or ash.

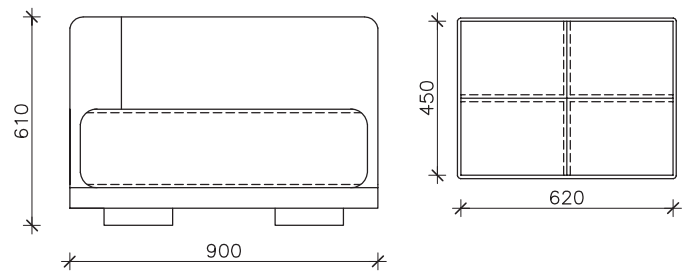
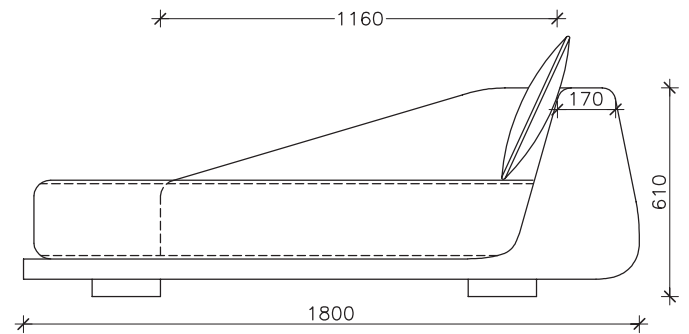
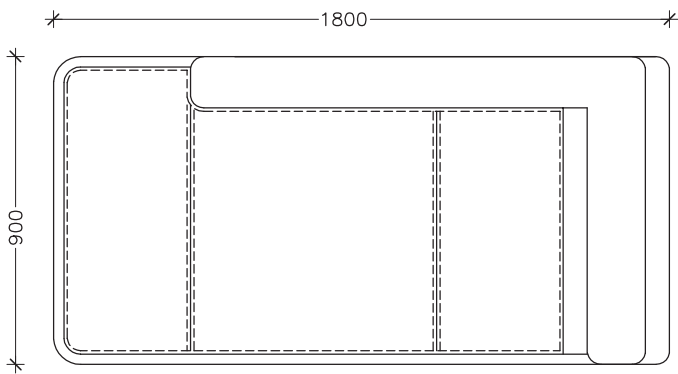

LEATHER OPTIONS | OPTIONAL C.O.M



WOOD OPTIONS



DIMENSIONS

1800W x 900D x 610H mm | SEAT HEIGHT: 340 mm

DESCRIPTION

Fully upholstered solid wood frame constitution, dual density foam cushion.
Hidden feet below.

DESIGNED BY OKHA

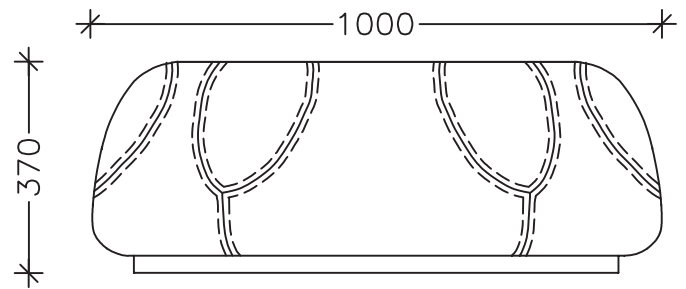
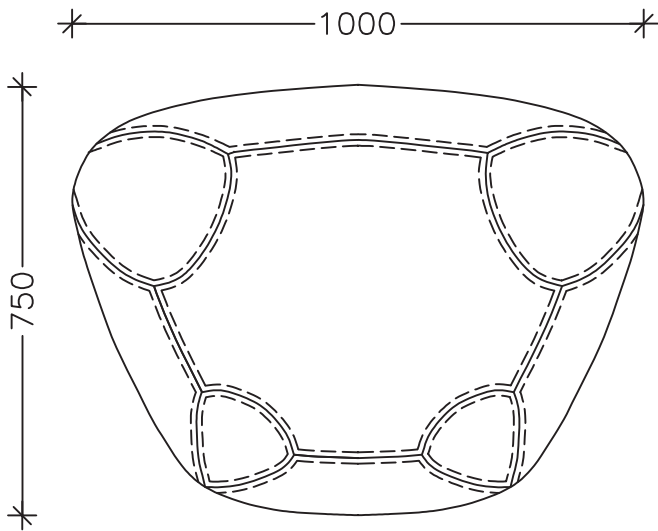

LEATHER OPTIONS | OPTIONAL C.O.M



DIMENSIONS

1000W x 750D x 370H mm | SEAT HEIGHT: 370 mm

DESCRIPTION

Upholstered solid wood frame with dual density foam core.
Frame options: natural or carbon stained oak or ash.

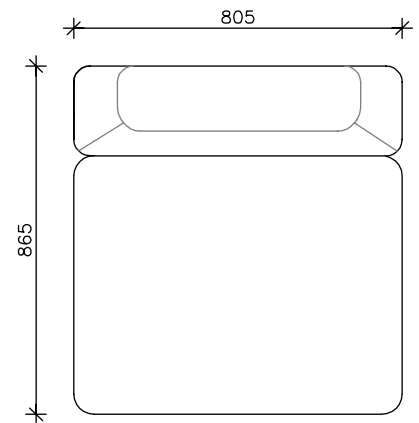
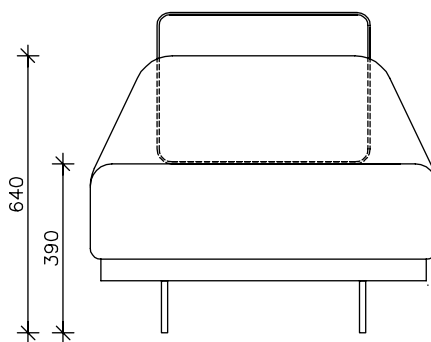
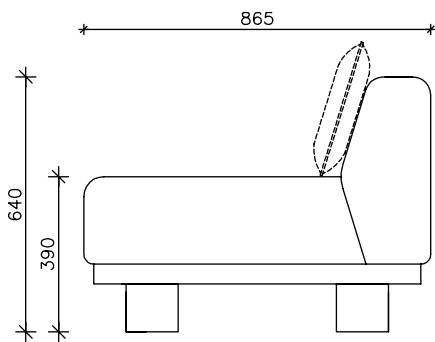

LEATHER OPTIONS | OPTIONAL C.O.M



DIMENSIONS

805W x 865D x 640H mm | SEAT HEIGHT 390 mm

DESCRIPTION

Solid wood frame construction, powdercoated stainless steel feet, dual density foam cushion upholstered with loose back scatter cushion.

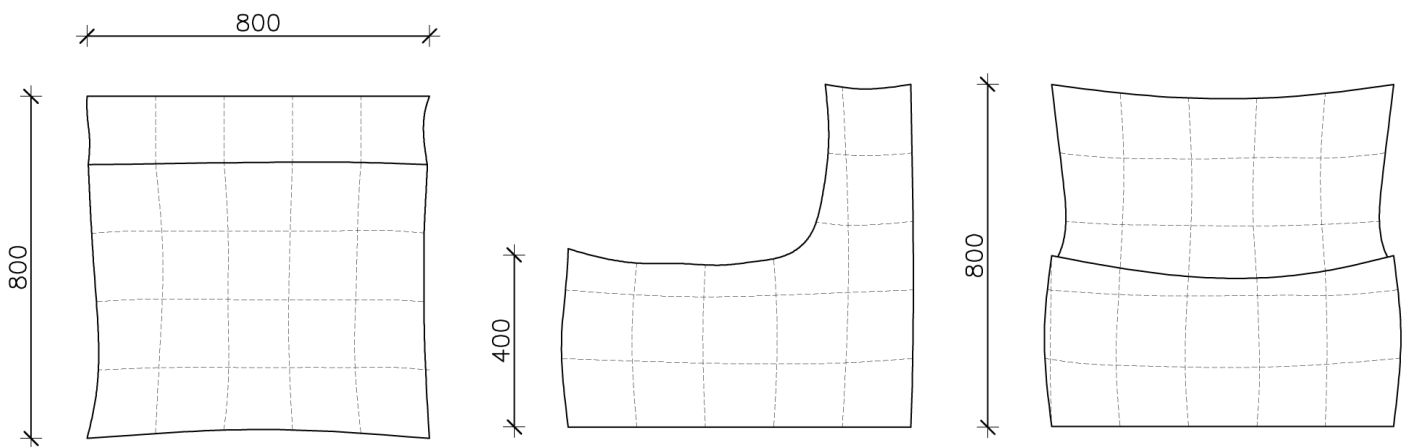
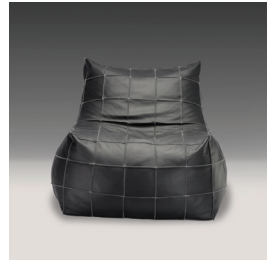

LEATHER OPTIONS | COM AVAILABLE



Black

Anthracite

Elephant

Latte

Mocca

Navy

Oyster

White

DIMENSIONS

800W x 800D x 800H mm | SEAT HEIGHT: 400 mm

DESCRIPTION

Fully upholstered hand stitched panelled leather occasional seat.
Also available in fabric of choice. Polystyrene inners.

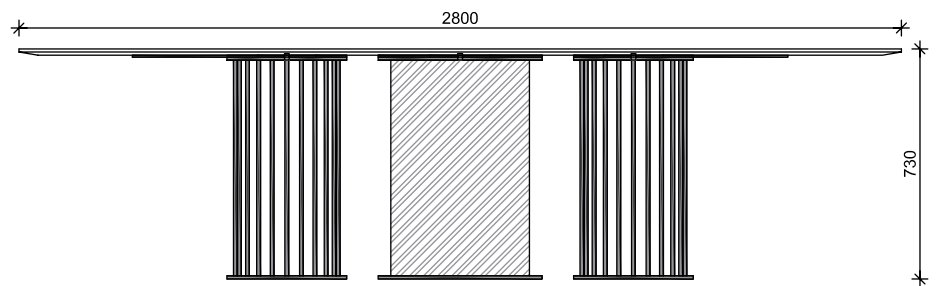
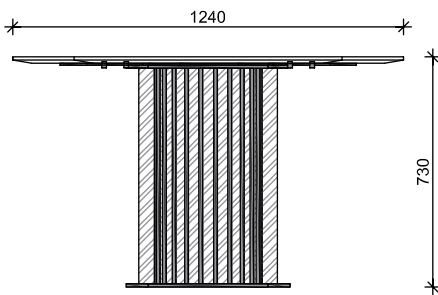
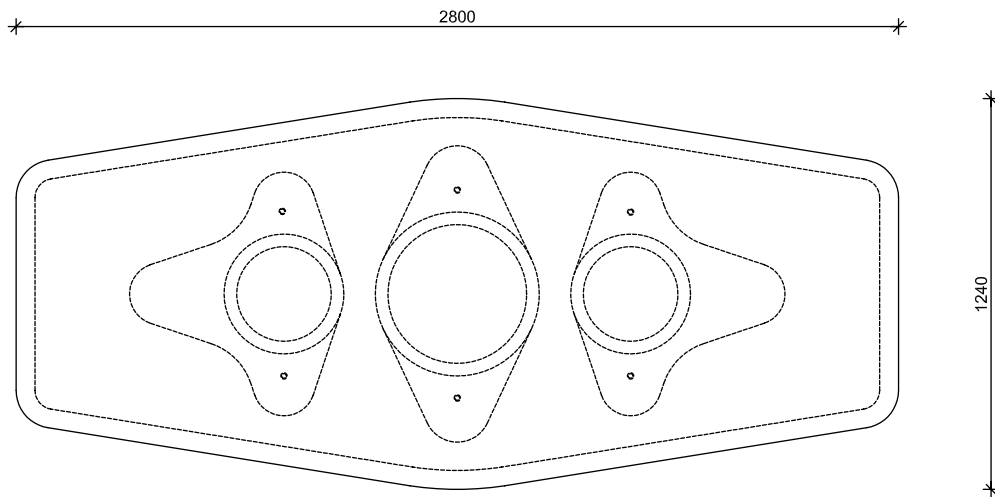

DIMENSIONS

2800W x 1240D x 730H mm

DESCRIPTION

20mm Dekton Top with bottom Reserve Chamfer upon
3-piece Blackened Steel Cylindrical Base

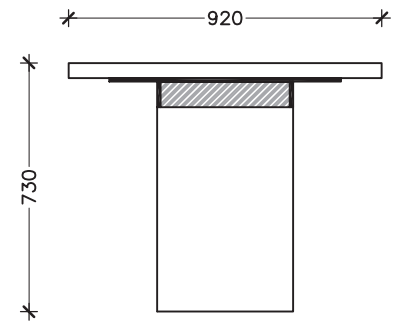
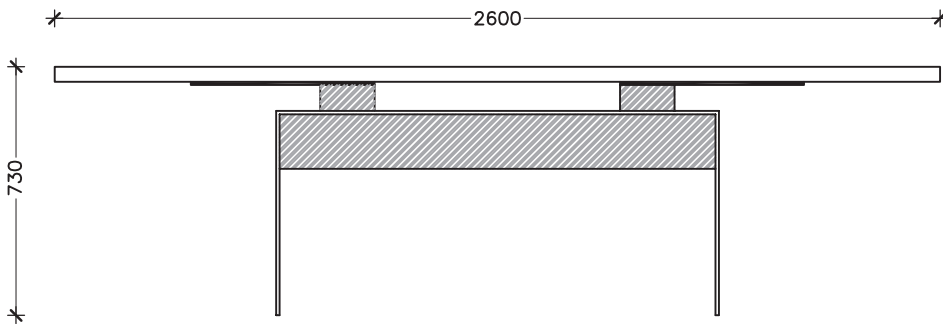

WOOD OPTIONS



Natural Oak

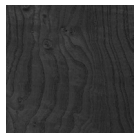

Carbon Oak



Chalked Oak

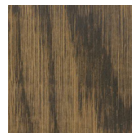

Dark Java Ash



Natural Ash

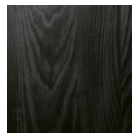

Carbon Ash



Walnut

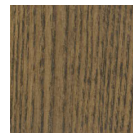

Dark Java Oak

DIMENSIONS

2600W x 920D x 730H mm

DESCRIPTION

Solid oak structure with solid composite top available in natural, white or carbon stain. Also available in walnut. Base options: black or white powder coated mild steel base.

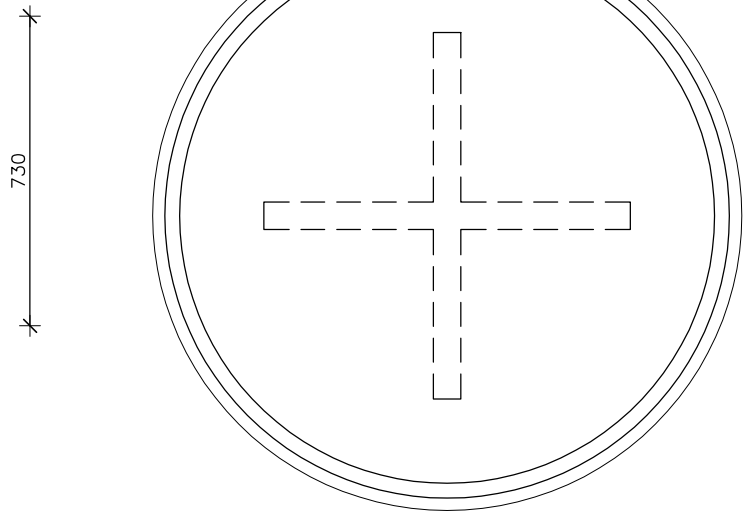
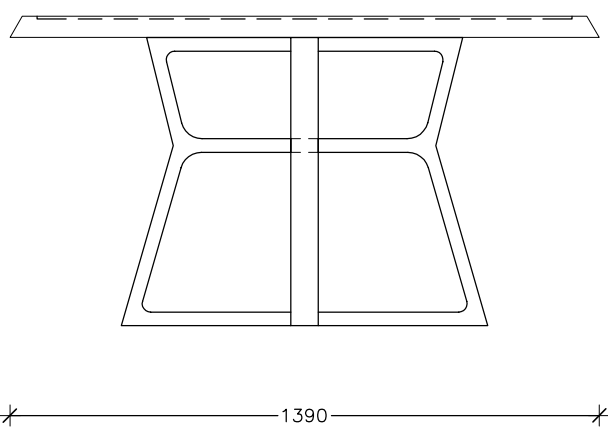

WOOD OPTIONS



Natural Oak



Carbon Oak



Chalked Oak

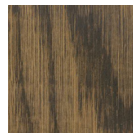

Dark Java Ash



Natural Ash

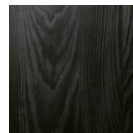

Carbon Ash



Walnut

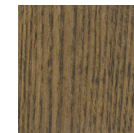

Dark Java Oak

DIMENSIONS

1390D x 730H mm

DESCRIPTION

Walnut or oak table available in natural, white or carbon stain with option of either glass or marble inlay top (upon request). Also available in walnut.

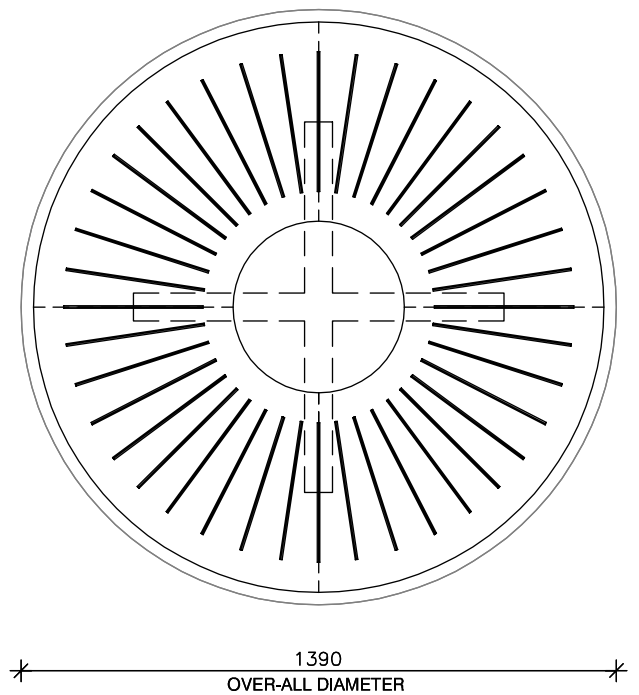
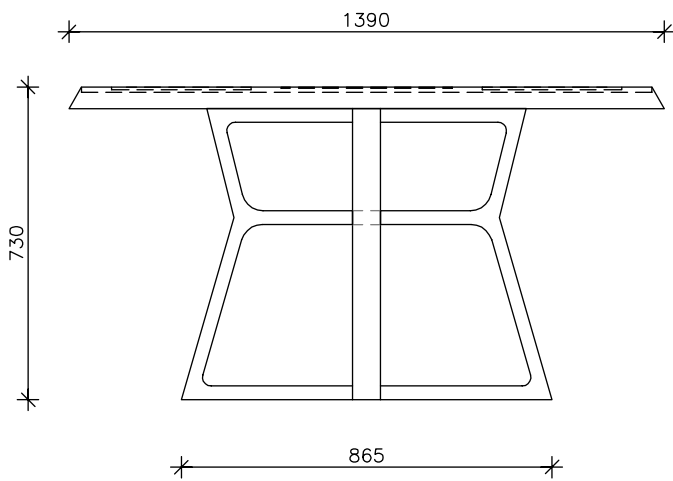

WOOD OPTIONS



Natural Oak



Carbon Oak



Chalked Oak

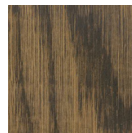

Dark Java Ash



Natural Ash



Carbon Ash



Walnut

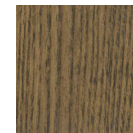

Dark Java Oak

DIMENSIONS

1390D x 730H mm

DESCRIPTION

Walnut or oak table available in natural, white or carbon stain with the option of glass, marble or brass inlay.

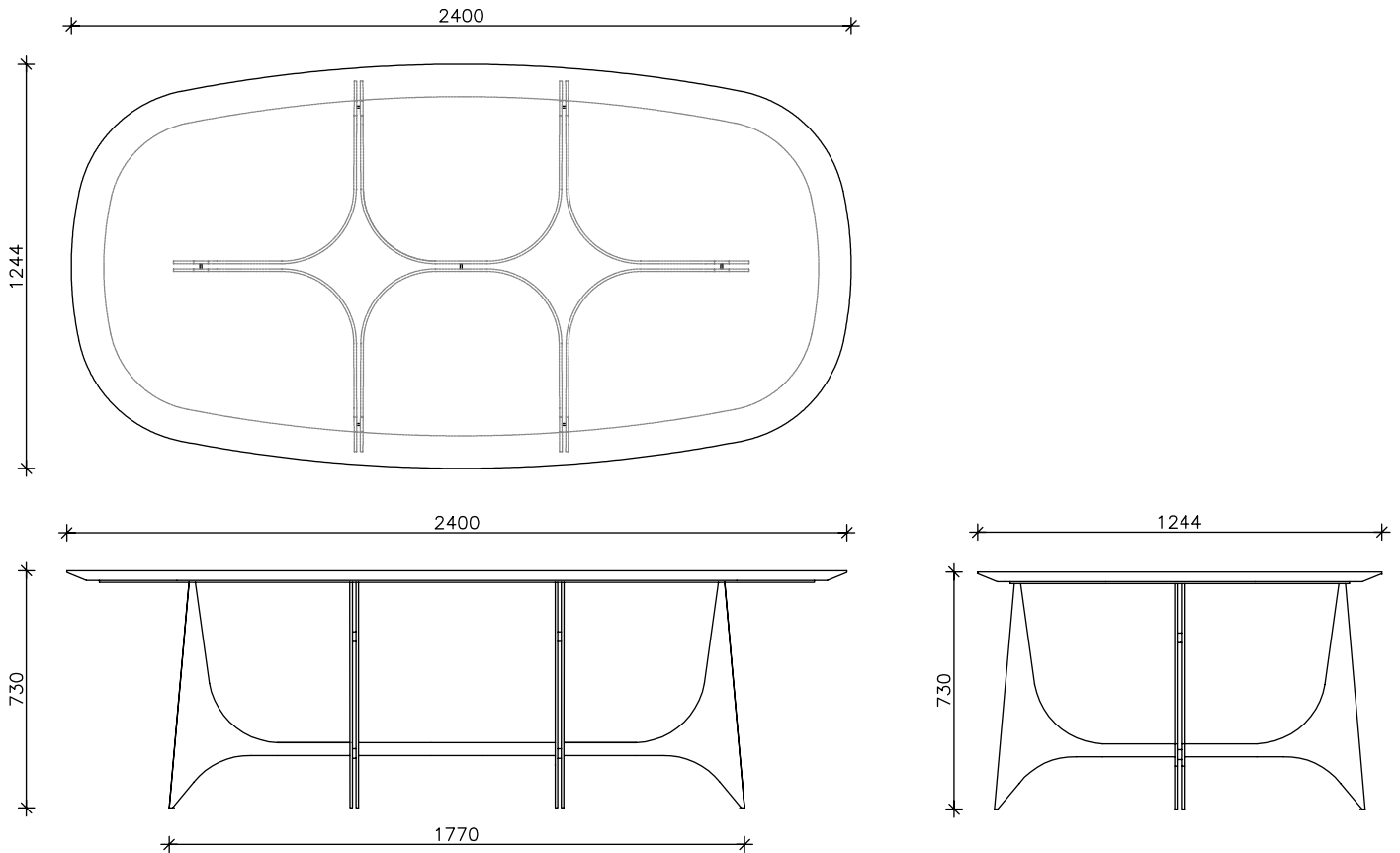

DIMENSIONS

2400W x 1244D x 730H mm

DESCRIPTION

Powder coated mild steel base available in black or white.
Table top available in Nero Marquina or Volakas marble. An additional choice of honed or polished marble tops is available upon request.

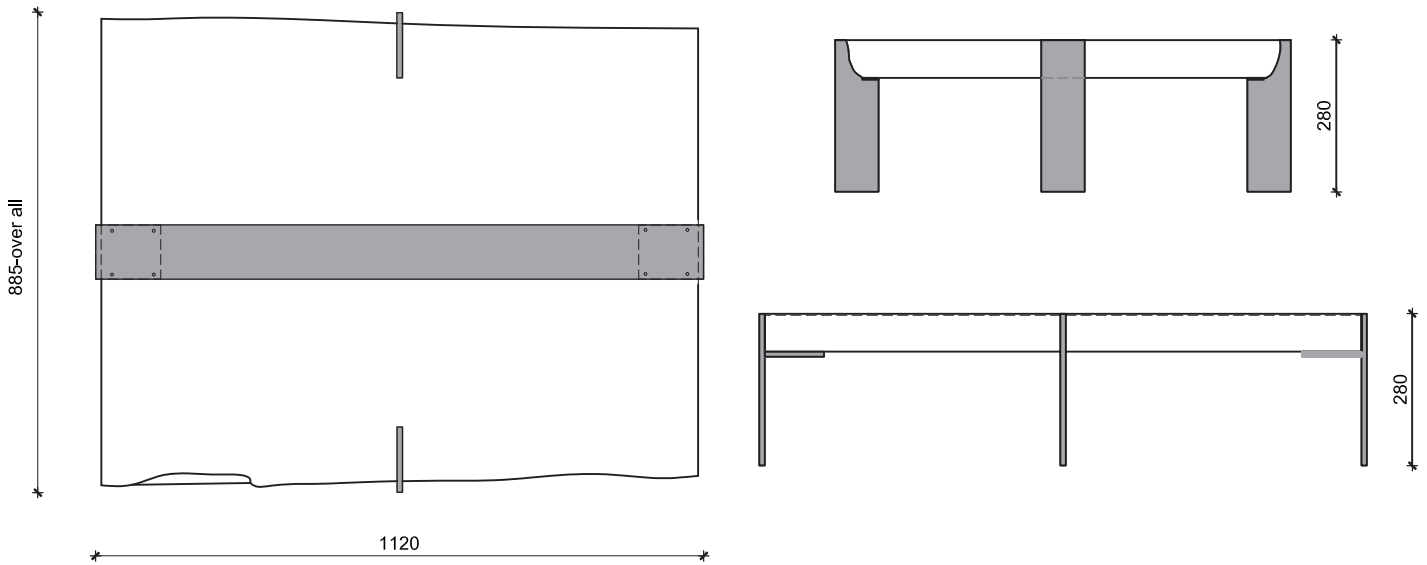

WOOD OPTIONS



Natural Oak



Carbon Oak



Chalked Oak

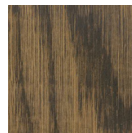

Dark Java Ash



Natural Ash



Carbon Ash

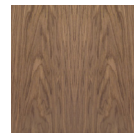

Walnut



Dark Java Oak

DIMENSIONS

1120W x 885D x 280H mm

DESCRIPTION

Solid Panga Panga wooden top with brass leg detail.

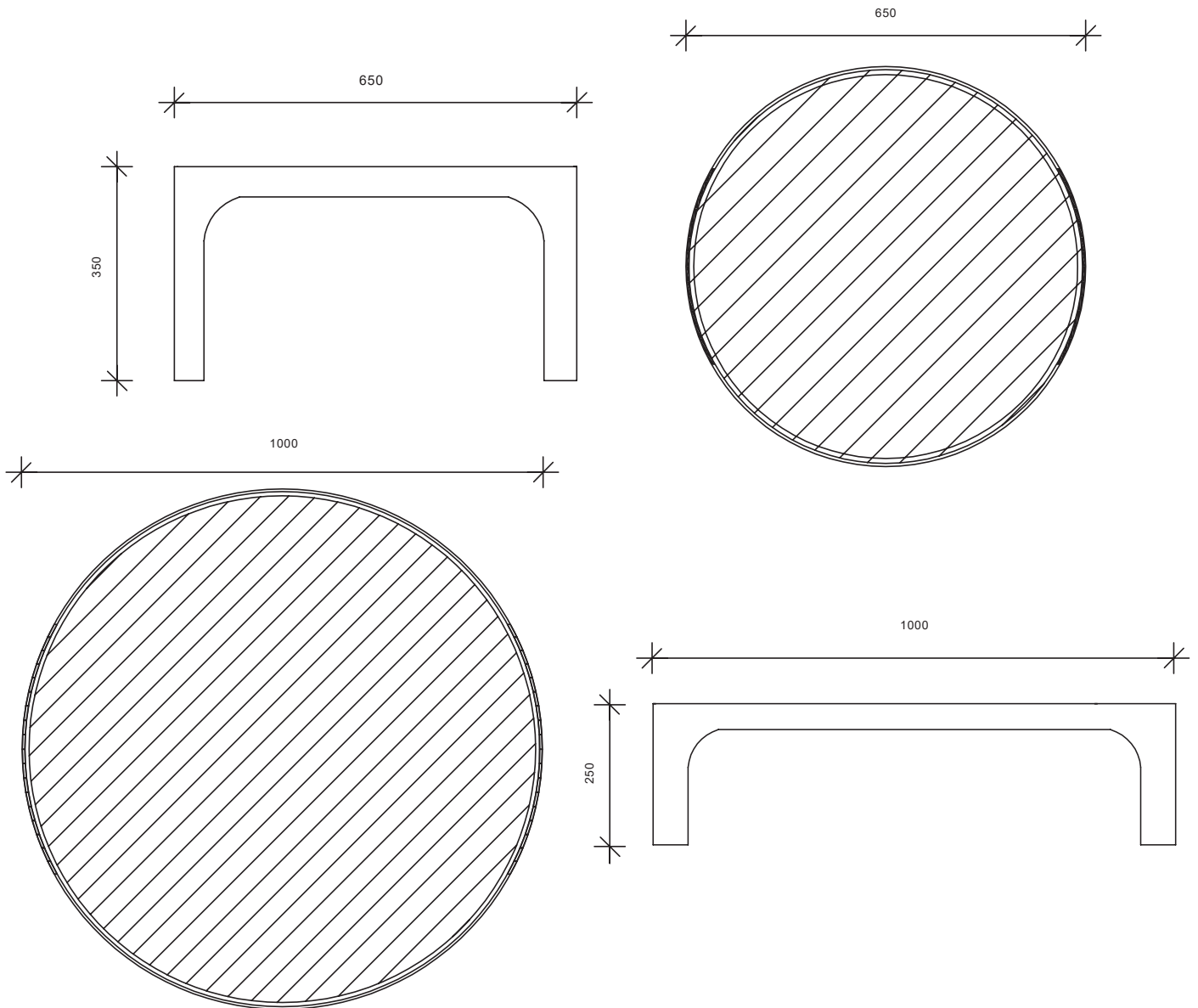

DIMENSIONS

SMALL: 650D x 350H mm

LARGE: 1000D x 270H mm

DESCRIPTION

Mild steel powder coated frame available in black, white or Saddlewood Ferrogain, 10 mm toughened glass top available in clear, grey, bronze tint or mirror. A choice of granite top inserts are available upon request.

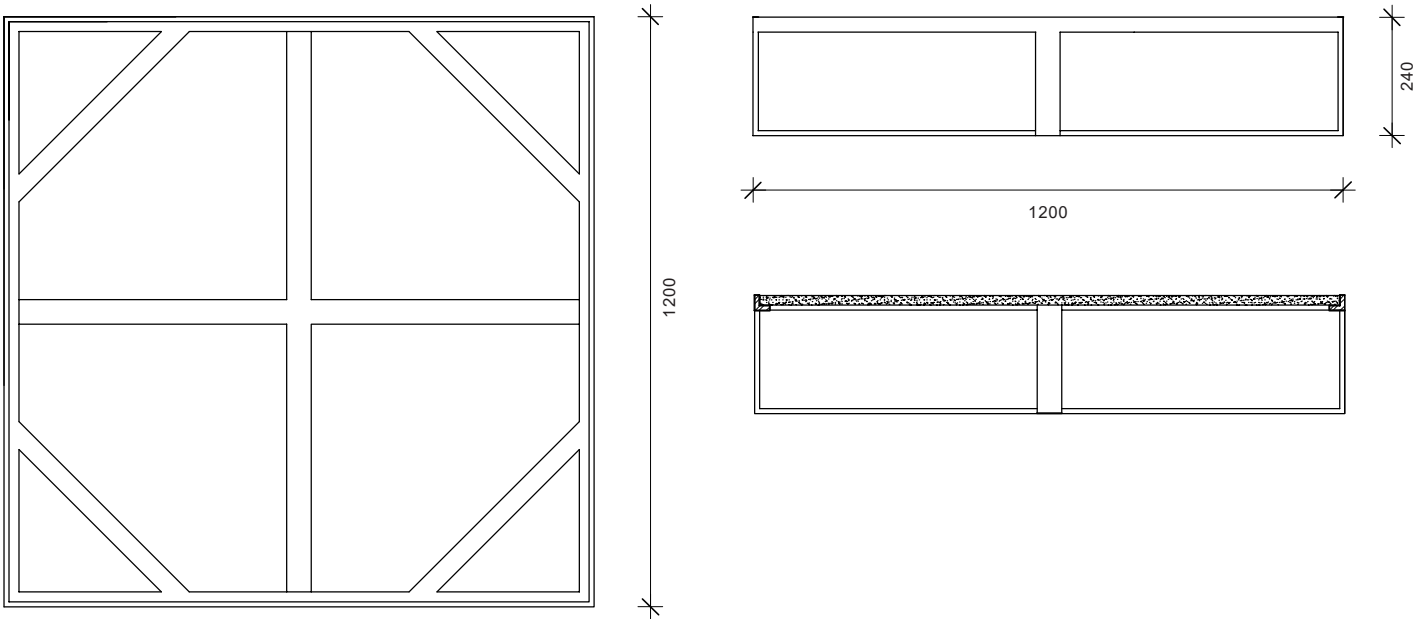
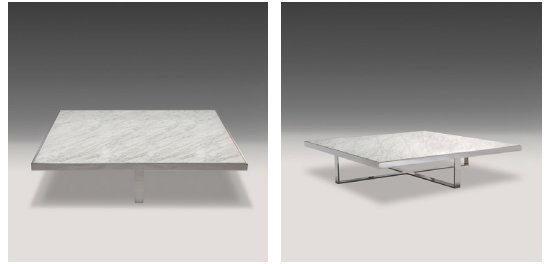

DIMENSIONS

1200W x 1200D x 240H mm

DESCRIPTION

Mirror polished stainless steel frame. Table top available in Nero Marquina or Volakas marble. An additional choice of polished marble tops are available upon request.

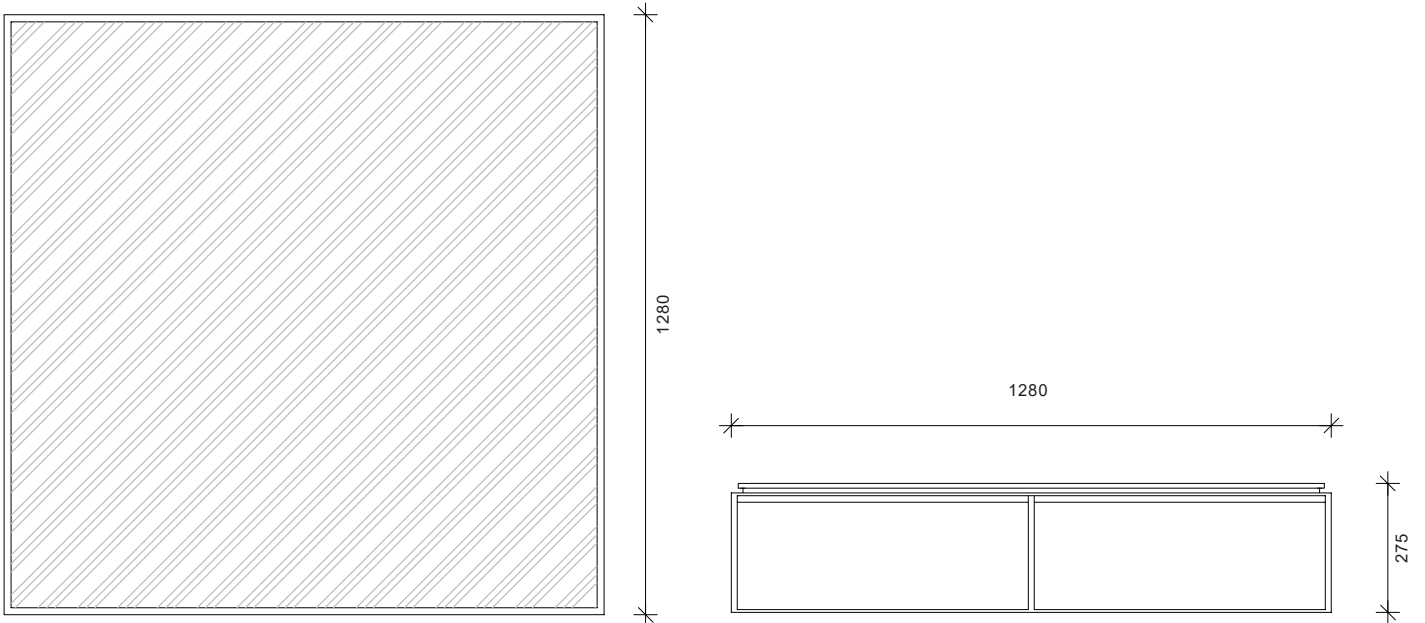

DIMENSIONS

1280W x 1280D x 275H mm

DESCRIPTION

Powder coated mild steel base available in black or white. Table top available in oak, walnut, Nero Marquina or Volakas marble. An additional choice of polished marble tops are available upon request.

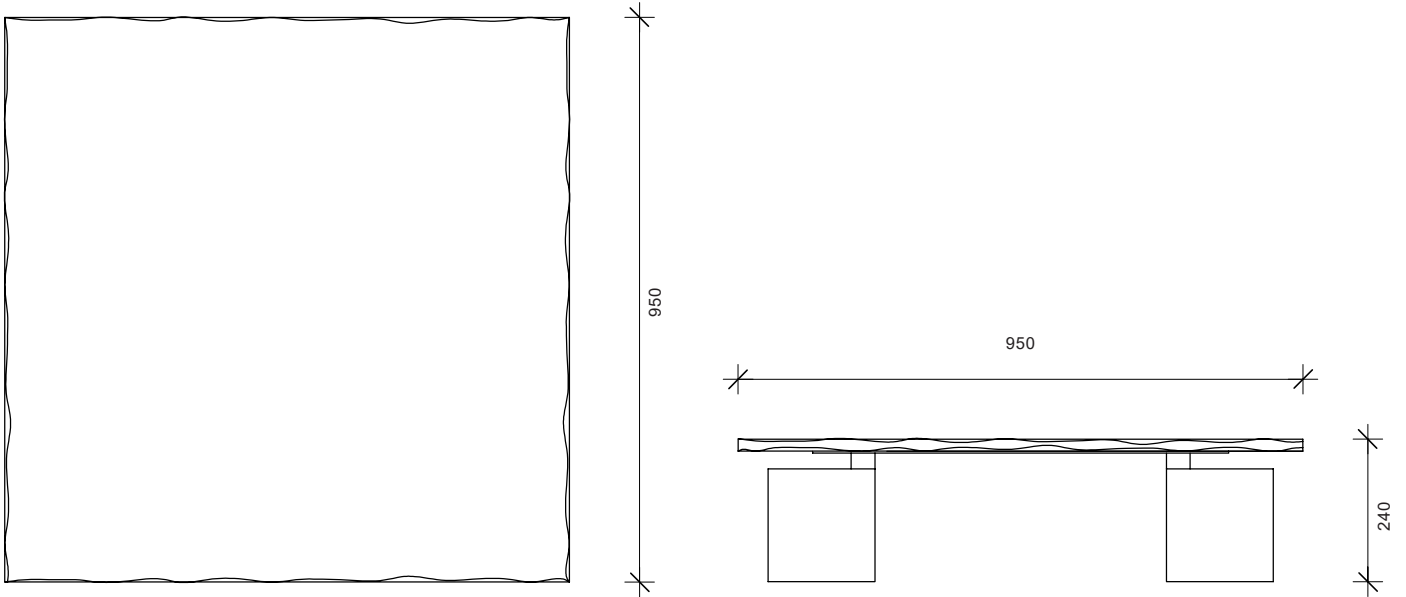

DIMENSIONS

950W x 950D x 240H mm

DESCRIPTION

Mirror polished stainless steel base and support. Available in nero marquina or volakas. An additional choice of polished marble tops is available upon request.

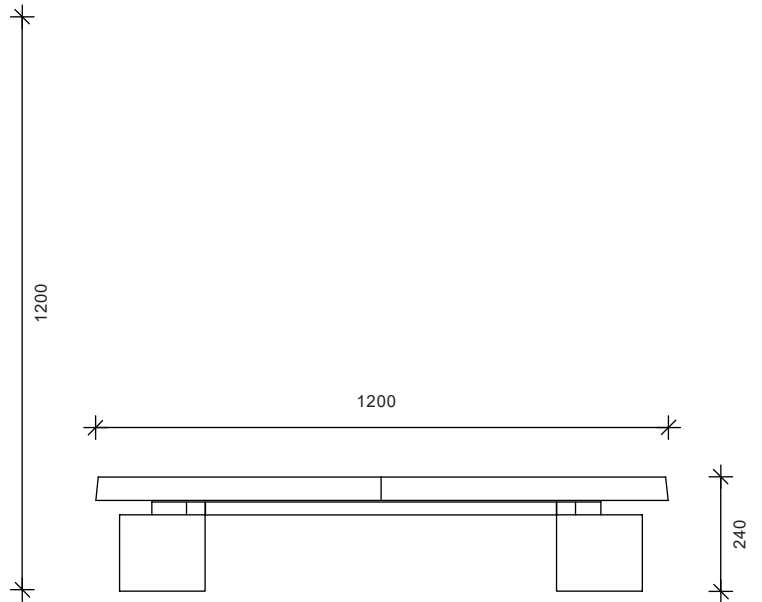
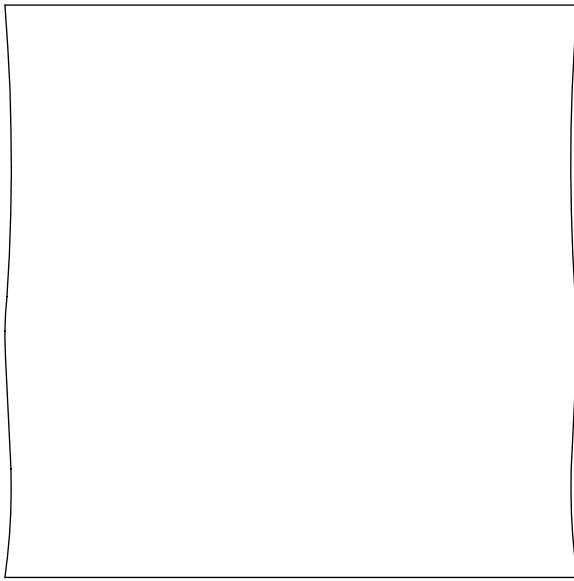

WOOD OPTIONS



Natural Oak

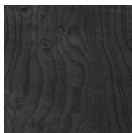

Carbon Oak



Chalked Oak

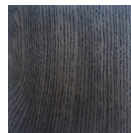

Mocca Oak



Natural Ash



Carbon Ash



Walnut

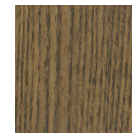

Dark Java Oak

DIMENSIONS

1200W x 1200D x 240H mm

DESCRIPTION

Mirror polished stainless steel base and support. Available in oak or walnut.

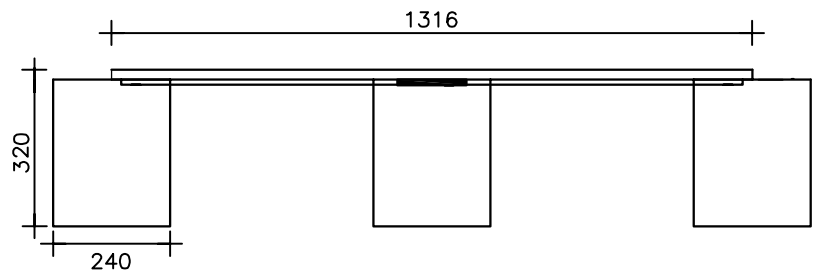
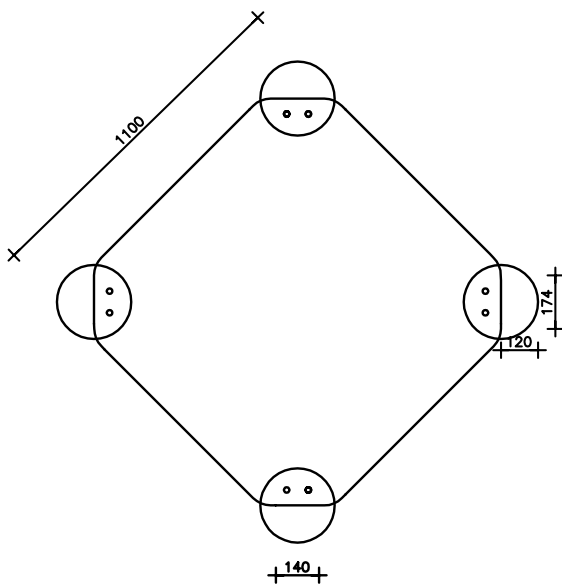

WOOD OPTIONS



Natural Oak

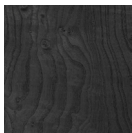

Carbon Oak



Chalked Oak

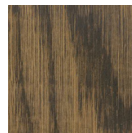

Dark Java Ash



Natural Ash



Carbon Ash



Walnut

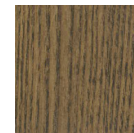

Dark Java Oak

DIMENSIONS

1100W x 320H mm

WEIGHT

80 kg unboxed

DESCRIPTION

Wire brushed Larch or other timber legs. Selection of stone tops available.

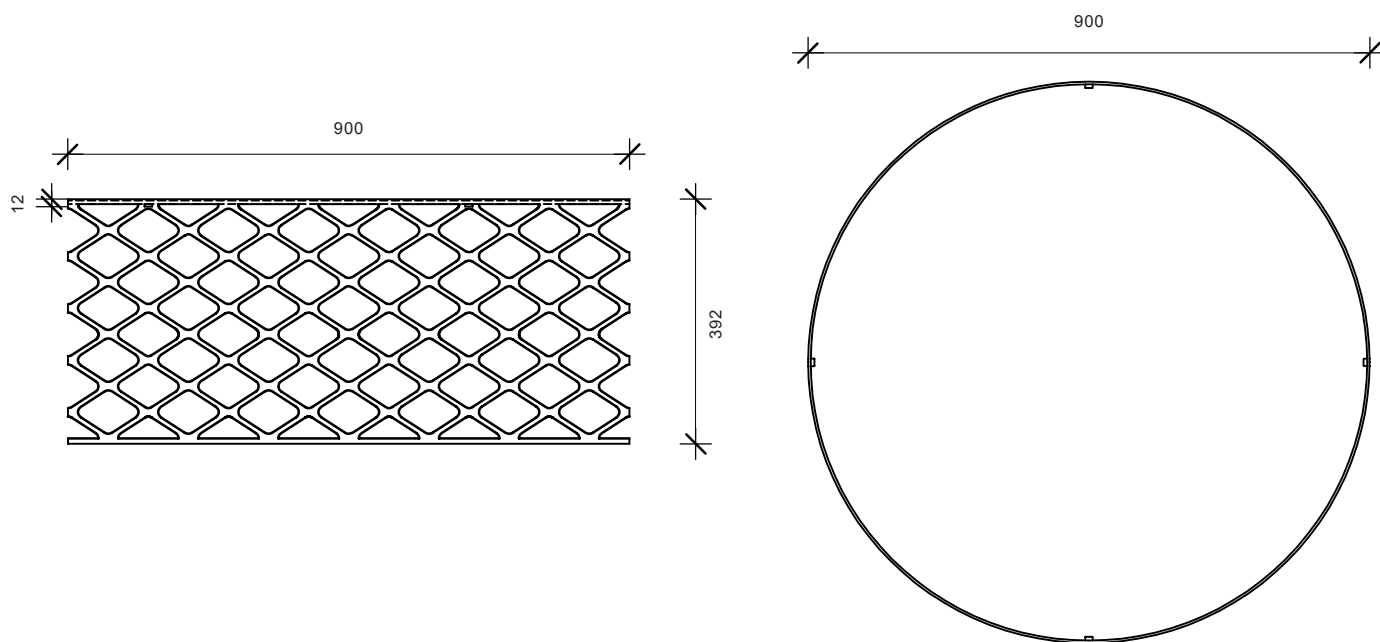
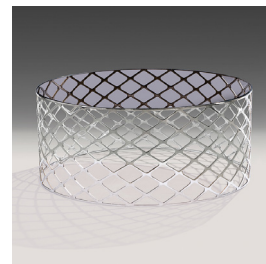

DIMENSIONS

900D x 392H mm

DESCRIPTION

Mirror polished stainless steel frame, toughened glass top available in clear, grey or bronze tint.

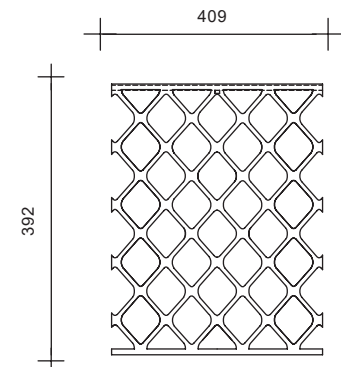
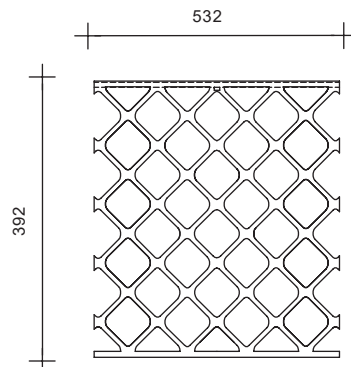
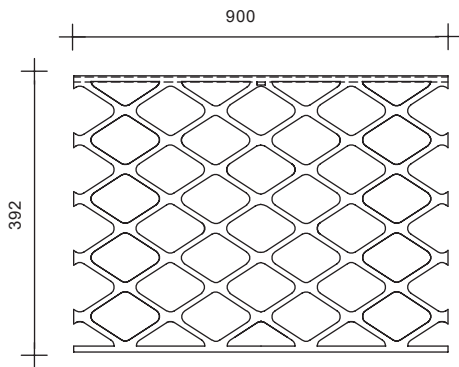
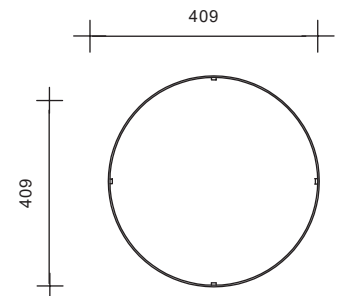
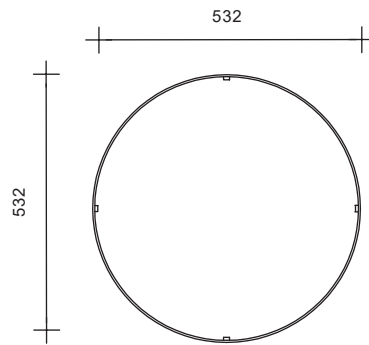
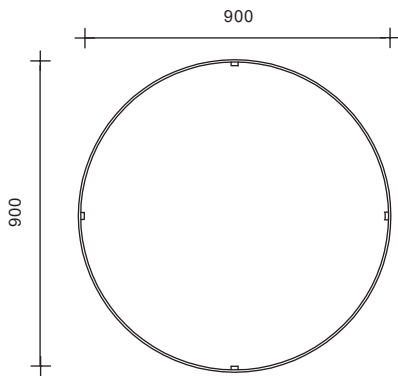

DIMENSIONS

SMALL: 409D x 392H mm

MEDIUM: 532D x 392H mm

LARGE: 900D x 392H mm

DESCRIPTION

Mirror polished stainless steel frame, toughened glass top available in clear, grey or bronze tint.

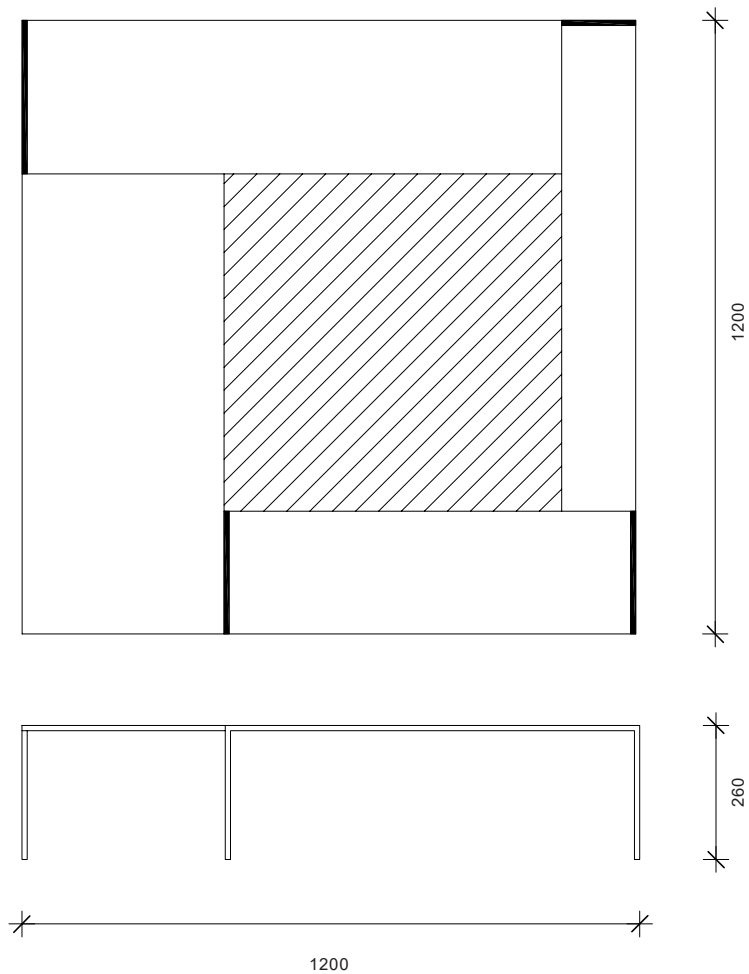

DIMENSIONS

1200W x 1200D x 260H mm

DESCRIPTION

Powder coated mild steel sections available in black & white with a 10 mm tinted glass insert. Also available in an oxidised mild steel frame.

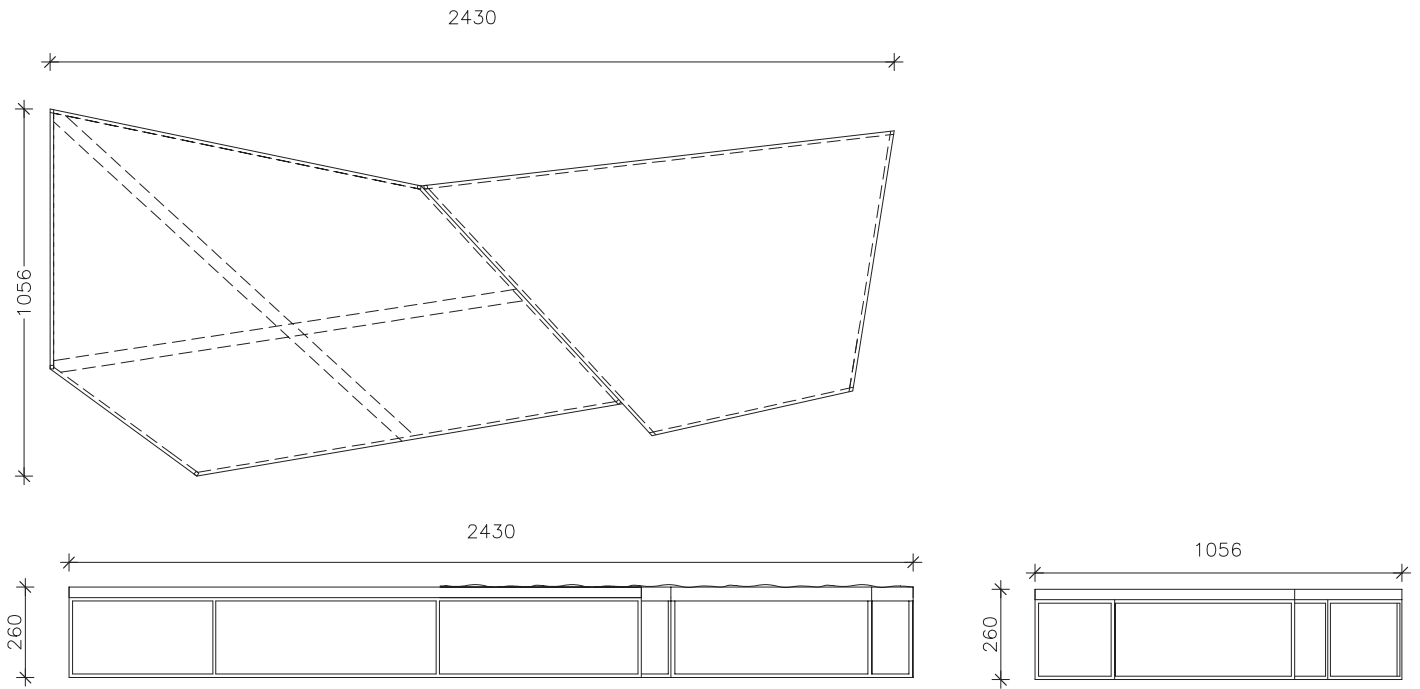
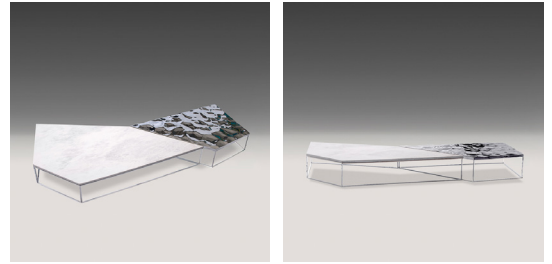

DIMENSIONS

2430W x 1056D x 260H mm

DESCRIPTION

Polished Brass frame. Table 1: Oxidised/Aged Brass. Table 2: 20 mm Volakas marble top. Also available in Nero Marquina. An additional choice of polished marble tops are available upon request.

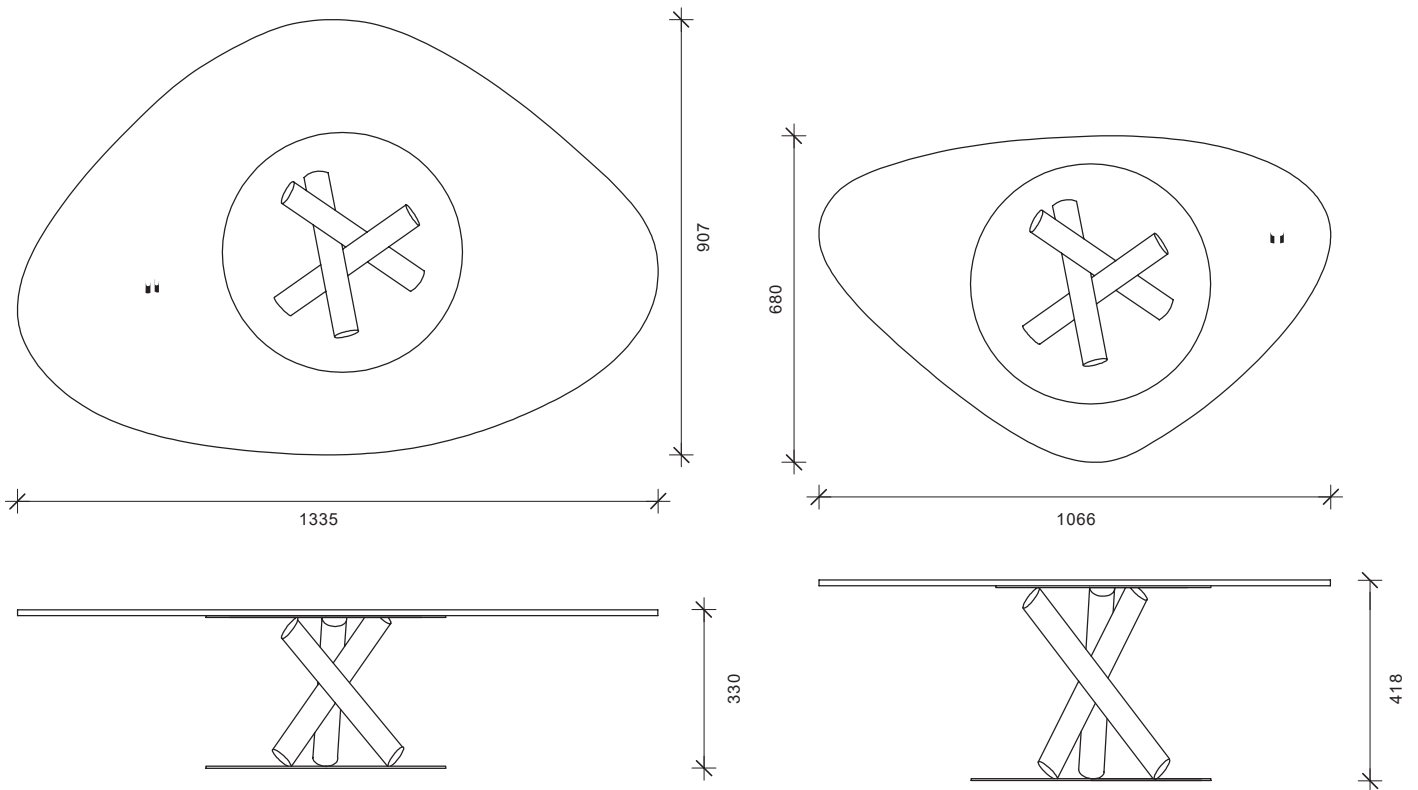

DIMENSIONS

SMALL: 1066W x 680D x 418H mm

LARGE: 1335W x 907D x 330H mm

DESCRIPTION

Corian table top, black or white powder coated mild steel base.

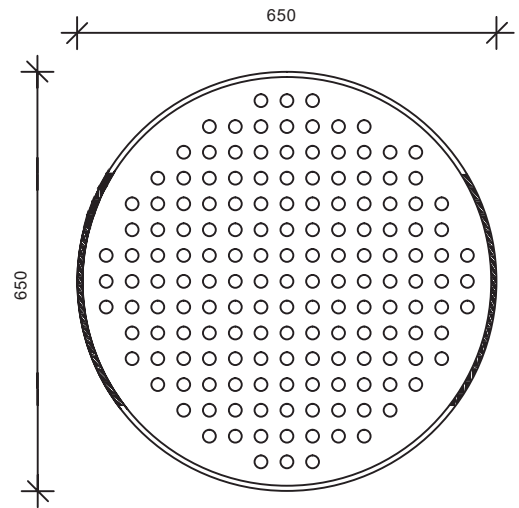
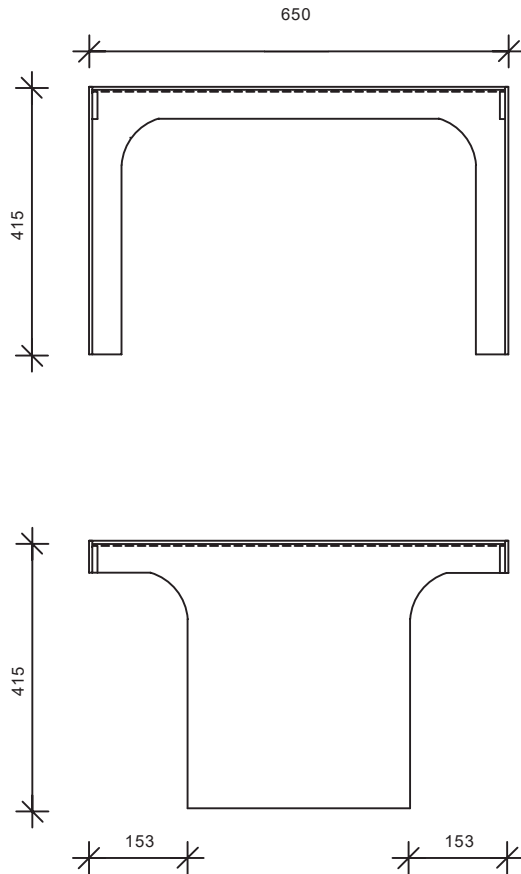

DIMENSIONS

SMALL: 650D x 415H mm

MEDIUM: 800D x 350H mm

DESCRIPTION

Patinated mild steel frame construction, with perforated solid Brass top.

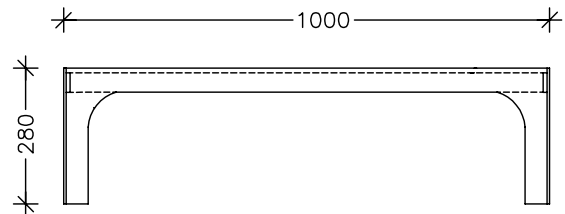
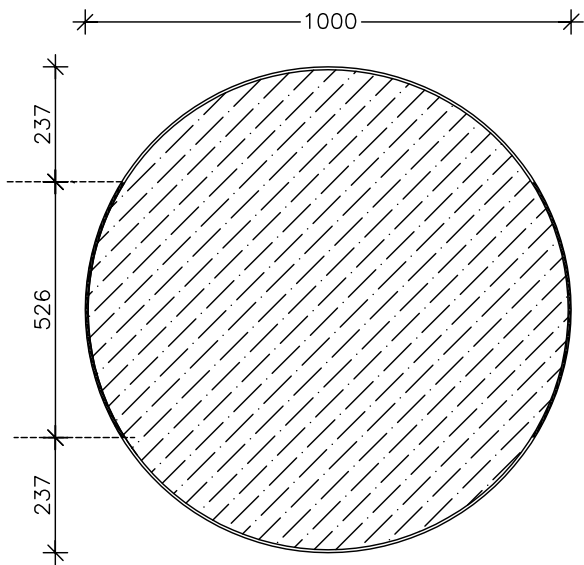
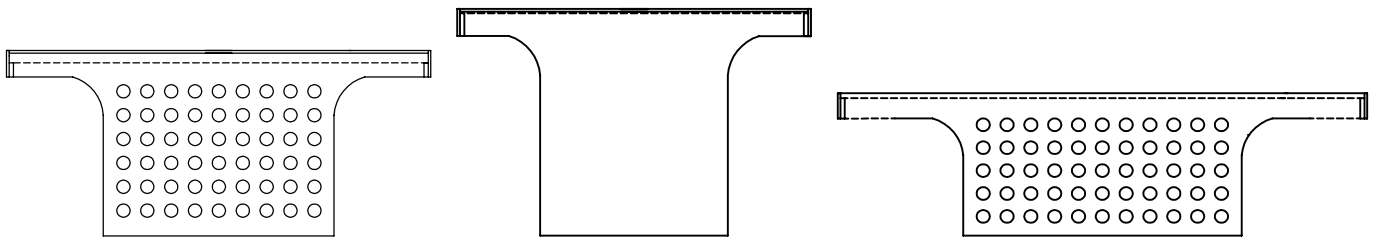

DIMENSIONS

LARGE: 1000D x 280H mm
MEDIUM: 800D x 350H mm
SMALL: 650D x 415H mm

DESCRIPTION

Patinated and perforated mild steel frame construction, and Nero Marquina polished marble top.

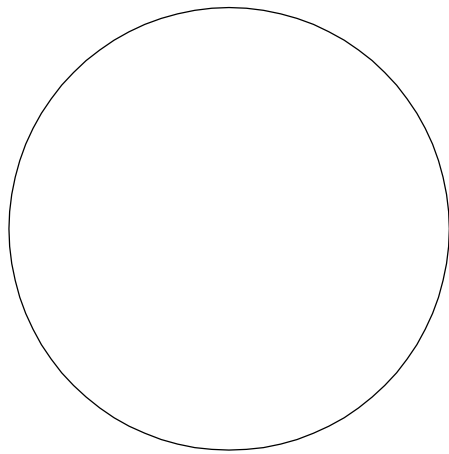

800

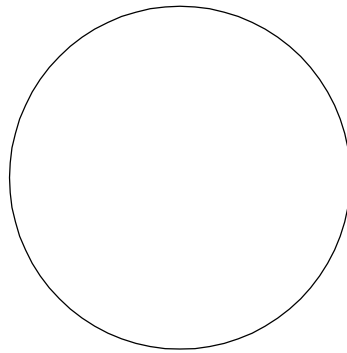

620

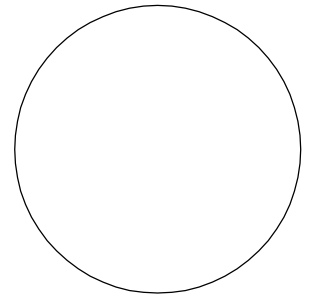

520

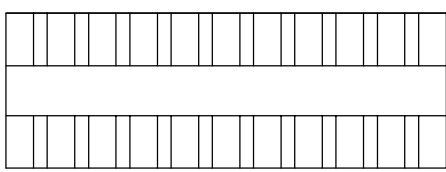

280

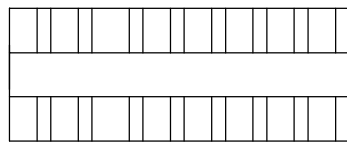

240

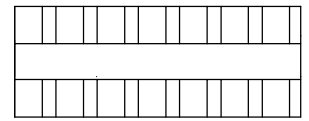

200

DIMENSIONS

SMALL: 520D x 200H mm

MEDIUM: 620D x 240H mm

LARGE: 800D x 280H mm

DESCRIPTION

Naturally felled solid eucalyptus. Belt detail available in mirror polished steel, waxed mild steel, copper or brass.

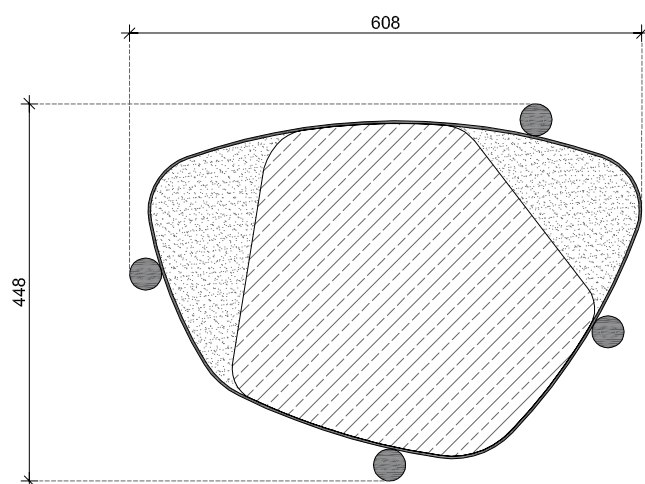
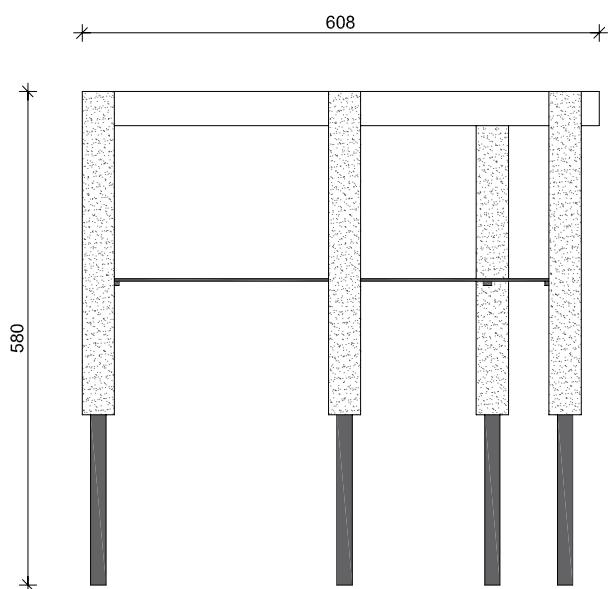

DIMENSIONS

608W x 448D x 580H mm

DESCRIPTION

Mirror polished solid brass base with toughened glass insert top in clear, grey or bronze tint. Upon request glass insert can be replaced with marble / granite of choice. Base also available in mirror polished stainless steel.

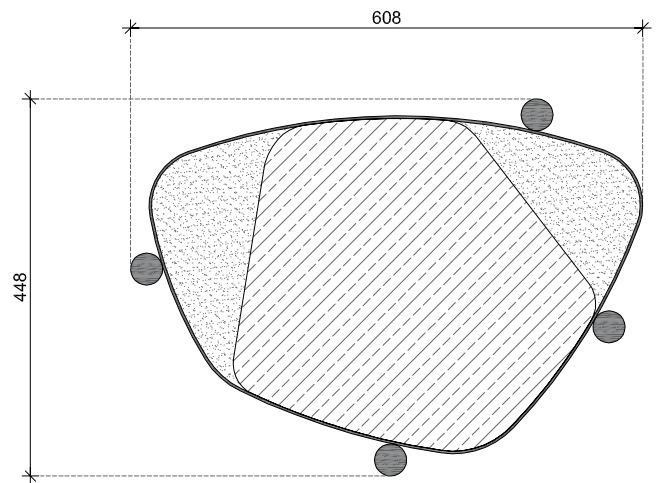
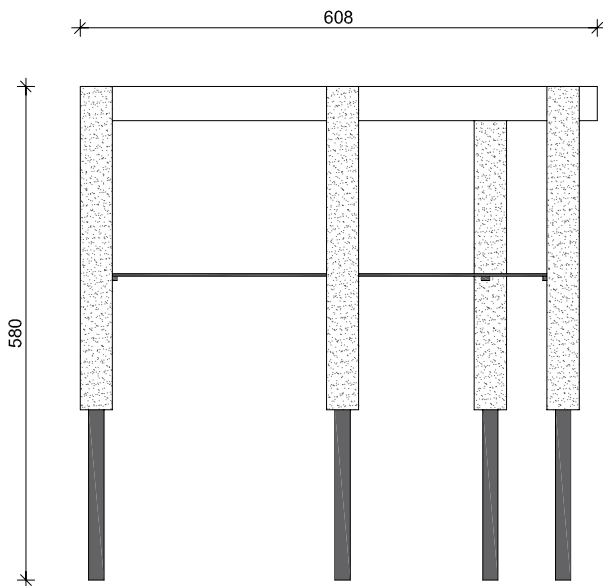
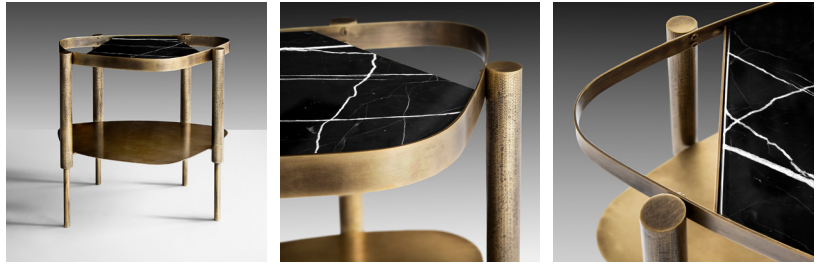

DIMENSIONS

608W x 448D x 580H mm

DESCRIPTION

Oxidized, aged and hammered solid brass with marble insert. Upon request marble insert can be replaced with granite of choice / toughened glass insert top in clear, grey or bronze tint. Base also available in mirror polished stainless steel.

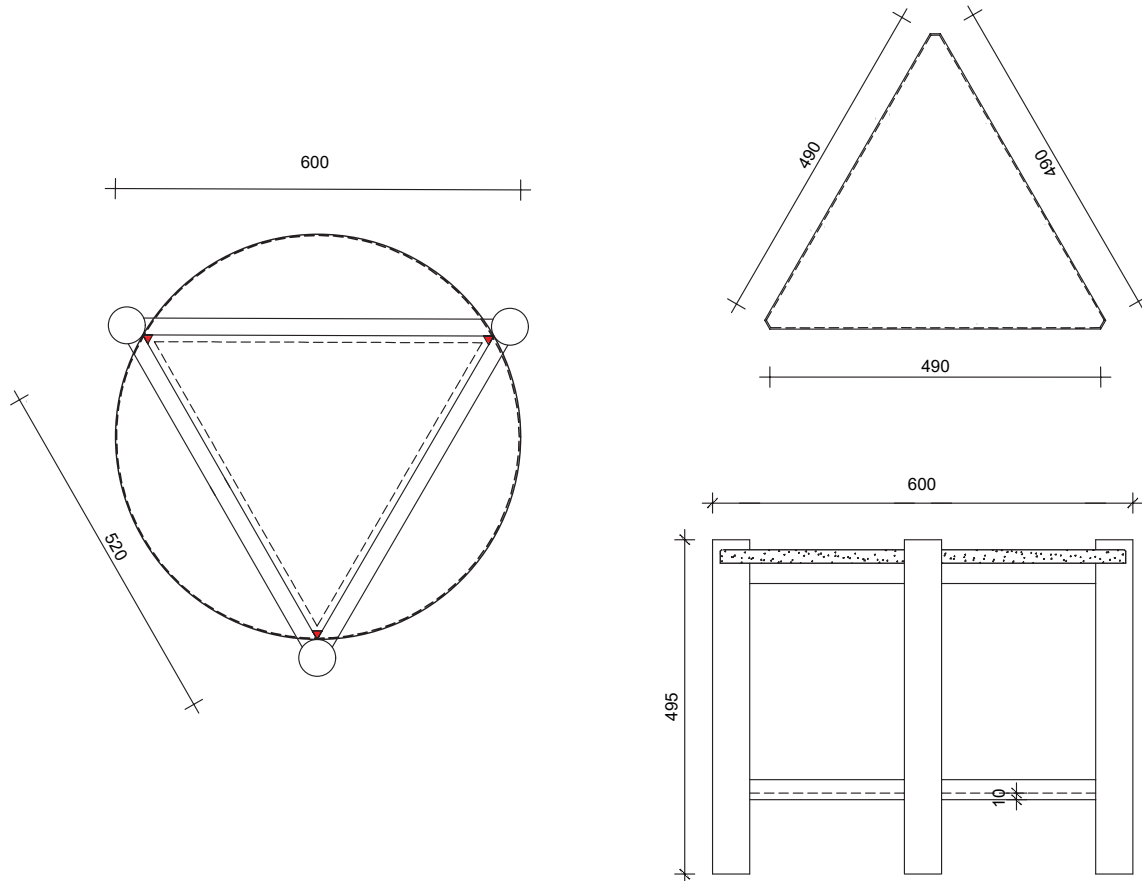

WOOD OPTIONS



Natural Oak

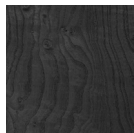

Carbon Oak



Chalked Oak

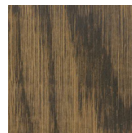

Dark Java Ash



Natural Ash



Carbon Ash



Walnut



Dark Java Oak

DIMENSIONS

600W x 495H mm

WEIGHT

20 kg unboxed

DESCRIPTION

Wire brushed Larch or other timber legs. Selection of stone tops available.

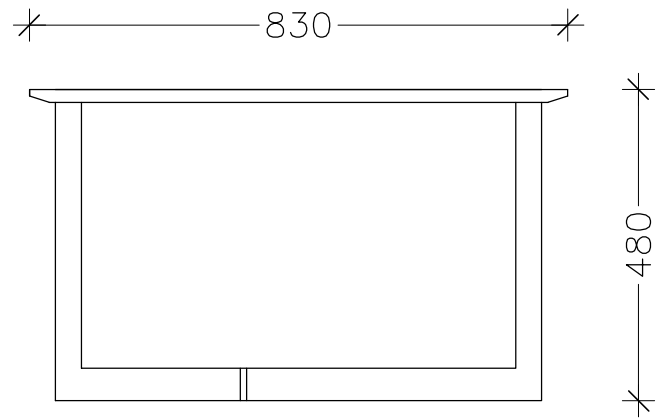
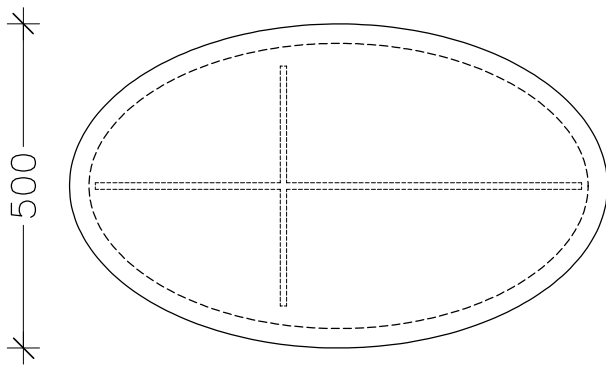

DIMENSIONS

830W x 500D x 480H mm

DESCRIPTION

Steel base with a variety of top options.

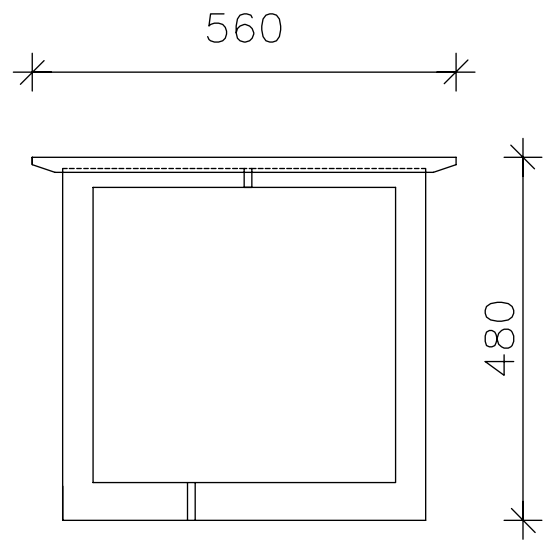
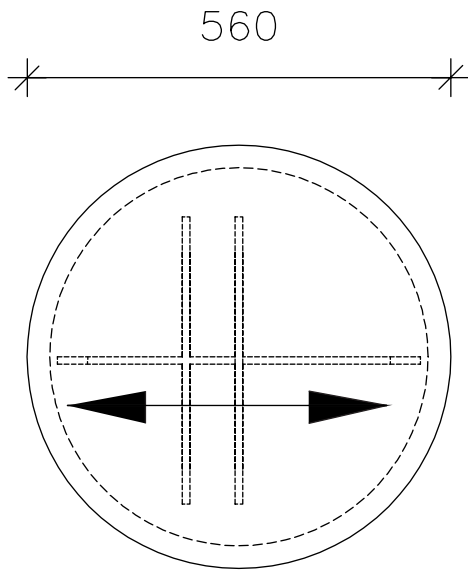

DIMENSIONS

350W x 480H mm

DESCRIPTION

Steel base with a variety of top options.

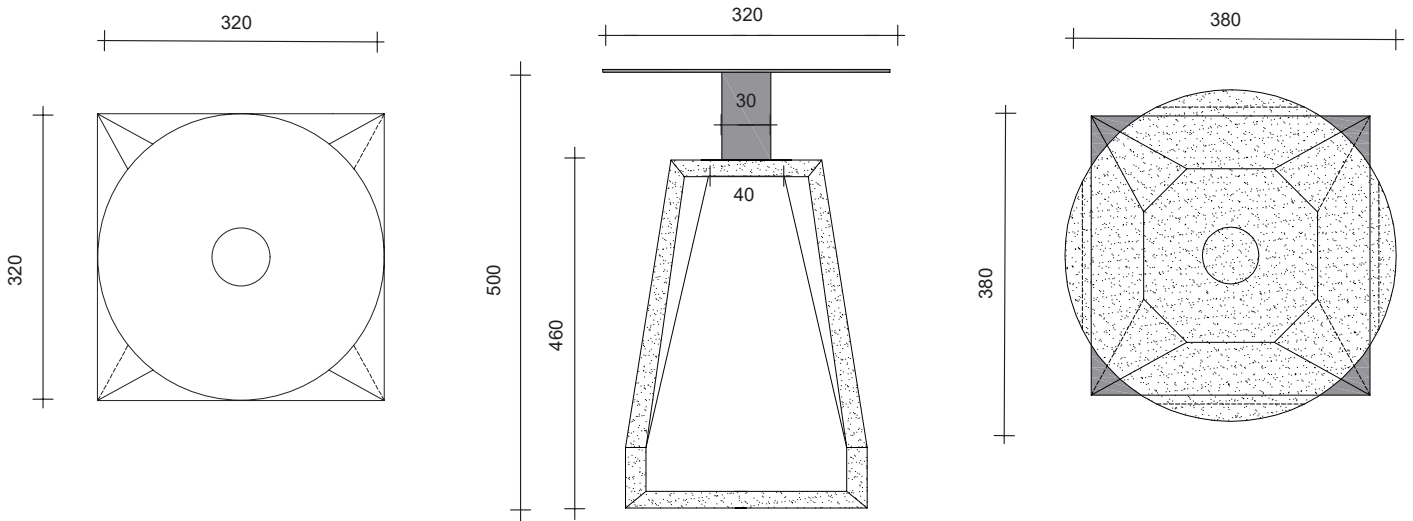

WOOD OPTIONS



Natural Oak



Carbon Oak



Chalked Oak

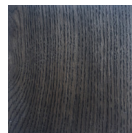

Mocca Oak



Natural Ash



Carbon Ash

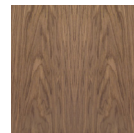

Walnut

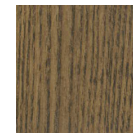

Dark Java Oak

DIMENSIONS

320W x 50H mm

WEIGHT

?? kg unboxed

DESCRIPTION

?

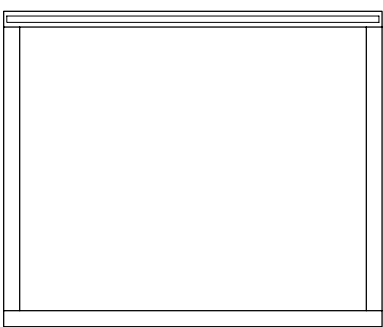

500

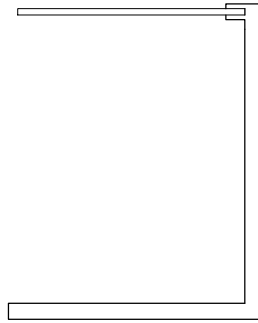

600

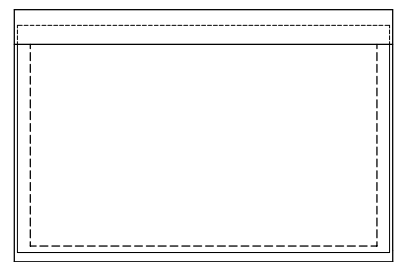

400

DIMENSIONS

600W x 400D x 500H mm

DESCRIPTION

Mirror polished stainless steel base, toughened glass top available in clear, grey or bronze tint.

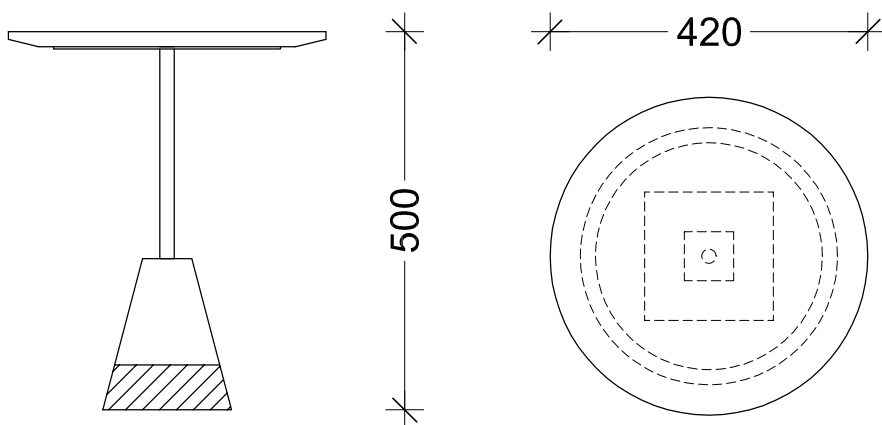
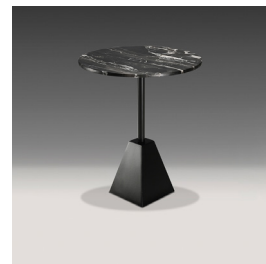

DIMENSIONS

420D x 500H mm

DESCRIPTION

Weighted powder coated mild steel base available in black or white with a variety of Marble Top options

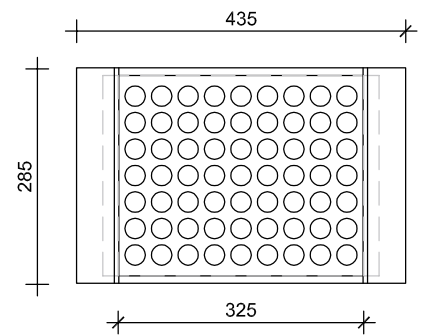
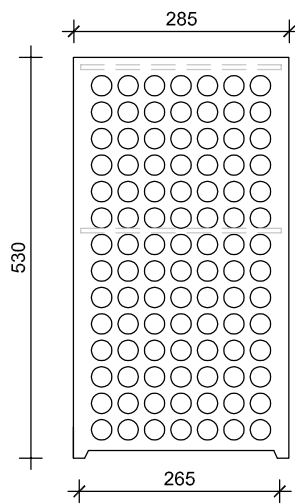
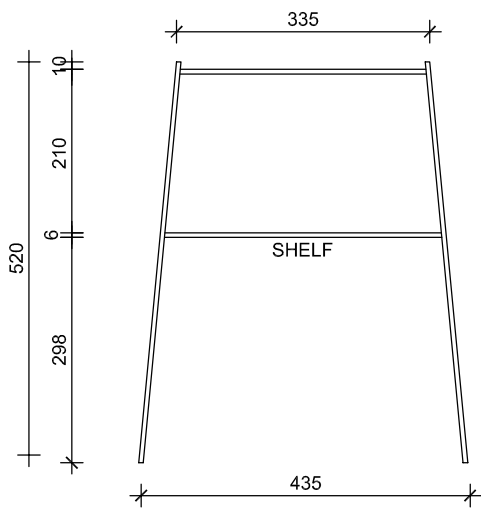

DIMENSIONS

435W x 285L x 520H mm

WEIGHT

1.5 kg unboxed

DESCRIPTION

Cold, rolled mild steel with patinated and waxed finish.

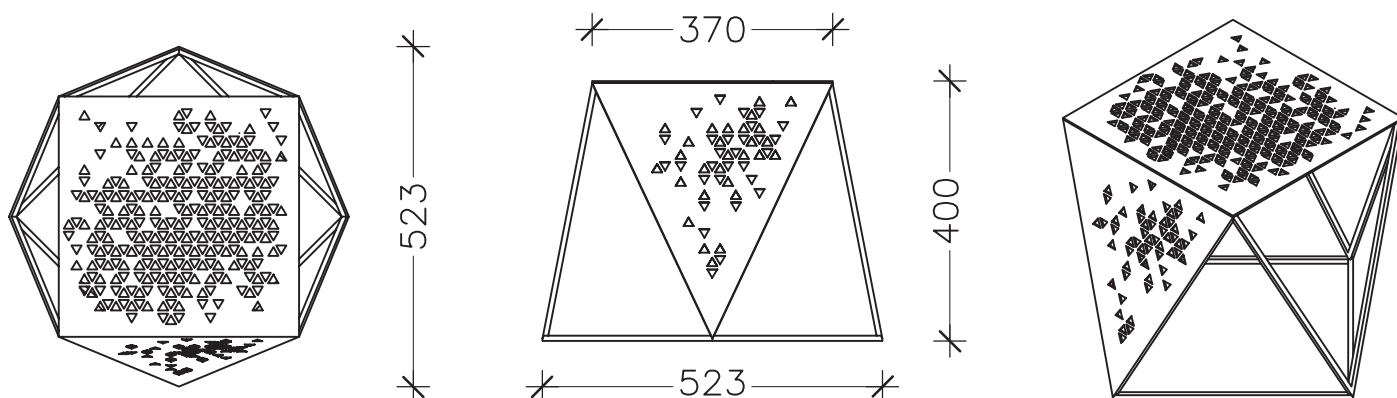

DIMENSIONS

523W x 523D x 400H mm

DESCRIPTION

Mirror polished stainless steel or powder coated mild steel structure available in black or white.

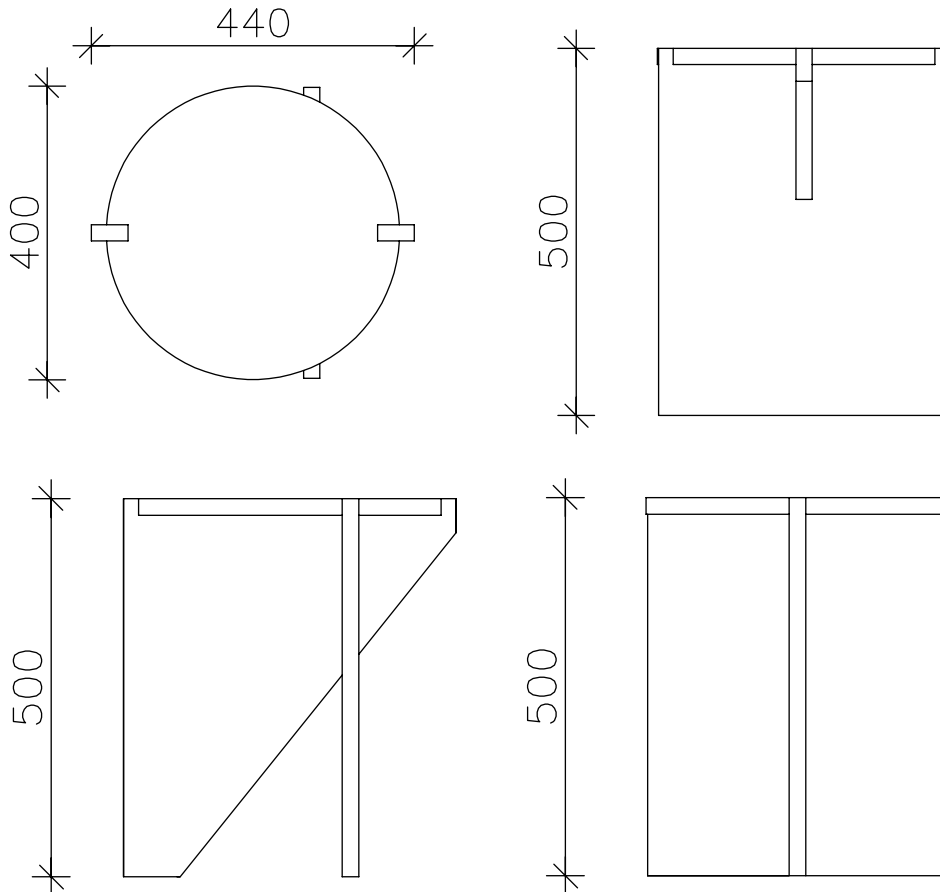

WOOD OPTIONS

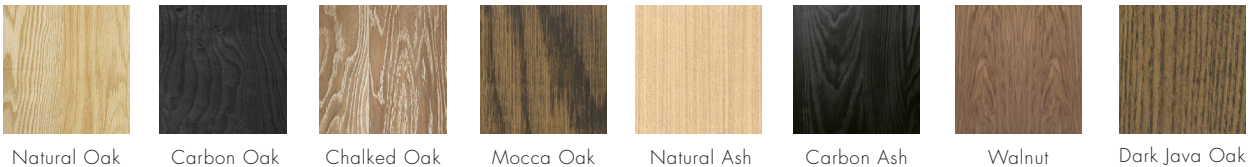

DIMENSIONS

440W x 400D x 500H mm

DESCRIPTION

Solid oak top and base.

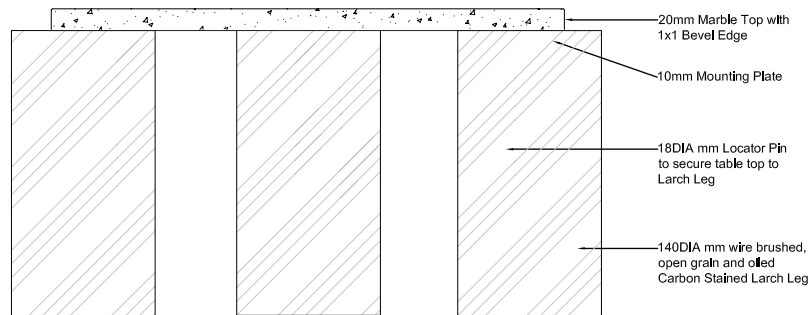
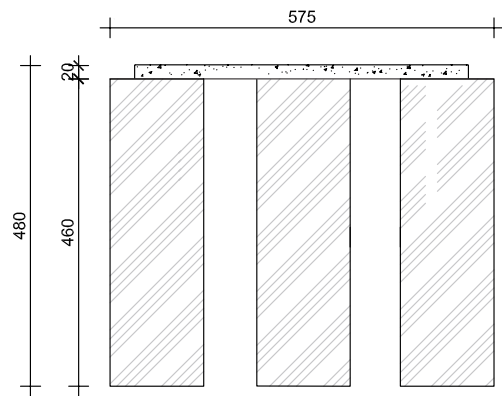
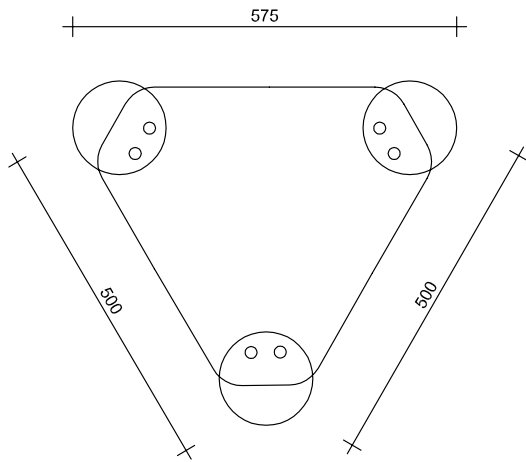

WOOD OPTIONS



Natural Oak



Carbon Oak



Chalked Oak

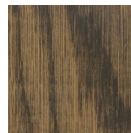

Dark Java Ash



Natural Ash



Carbon Ash



Walnut



Dark Java Oak

DIMENSIONS

575W x 480H mm

WEIGHT

25 kg unboxed

DESCRIPTION

Wire brushed Larch or other timber legs. Selection of stone tops available.

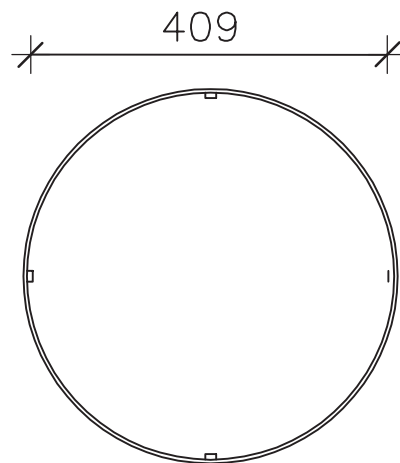
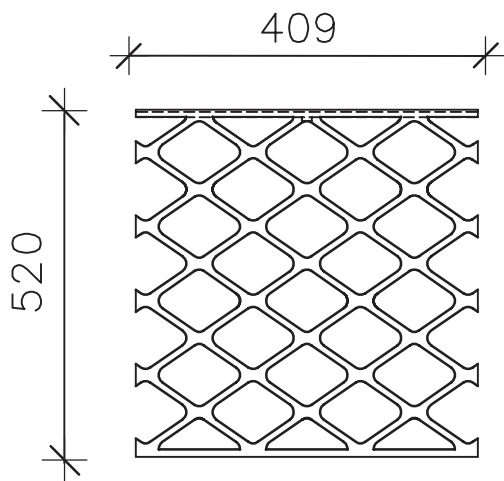
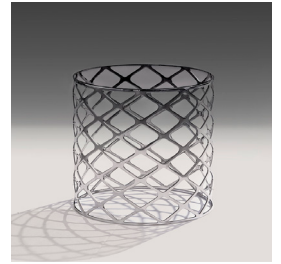

DIMENSIONS

409D x 520H mm

DESCRIPTION

Mirror polished stainless steel frame, toughened glass top available in clear, grey or bronze tint.

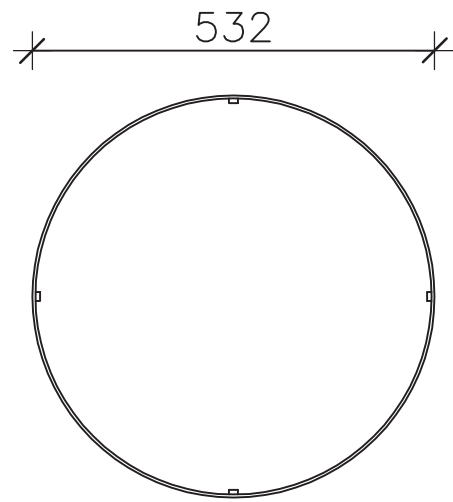
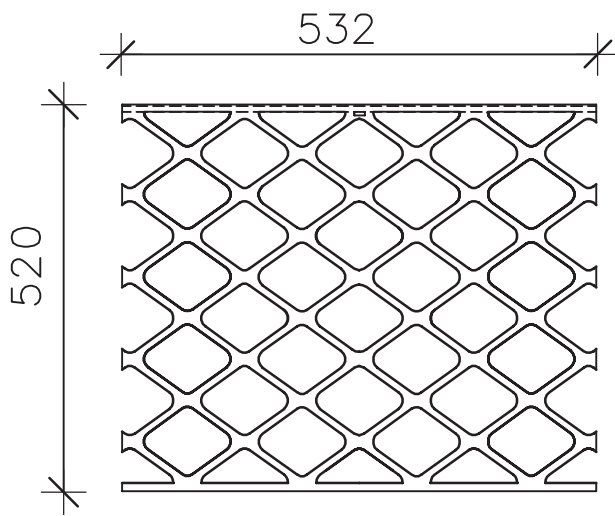
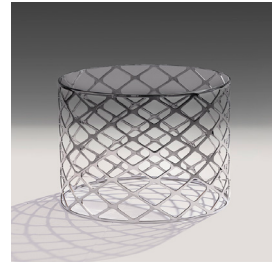

DIMENSIONS

532D x 520H mm

DESCRIPTION

Mirror polished stainless steel frame, toughened glass top available in clear, grey or bronze tint.

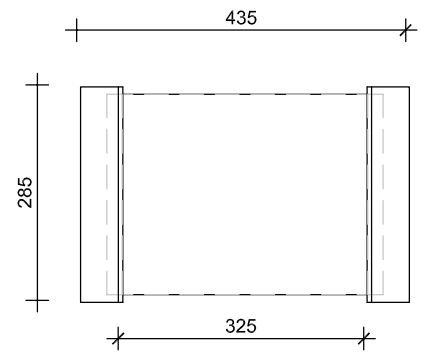
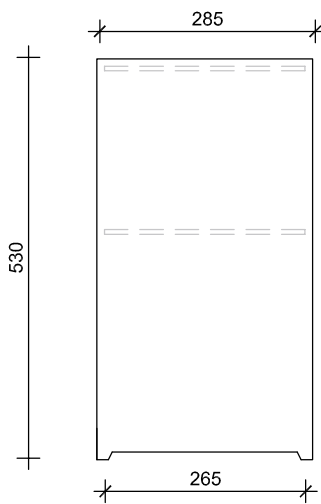
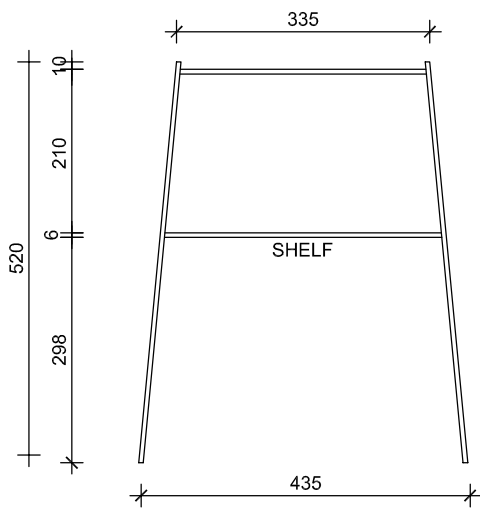

DIMENSIONS

435W x 285L x 520H mm

WEIGHT

20 kg unboxed

DESCRIPTION

Cold, rolled mild steel with patinated and waxed finish.

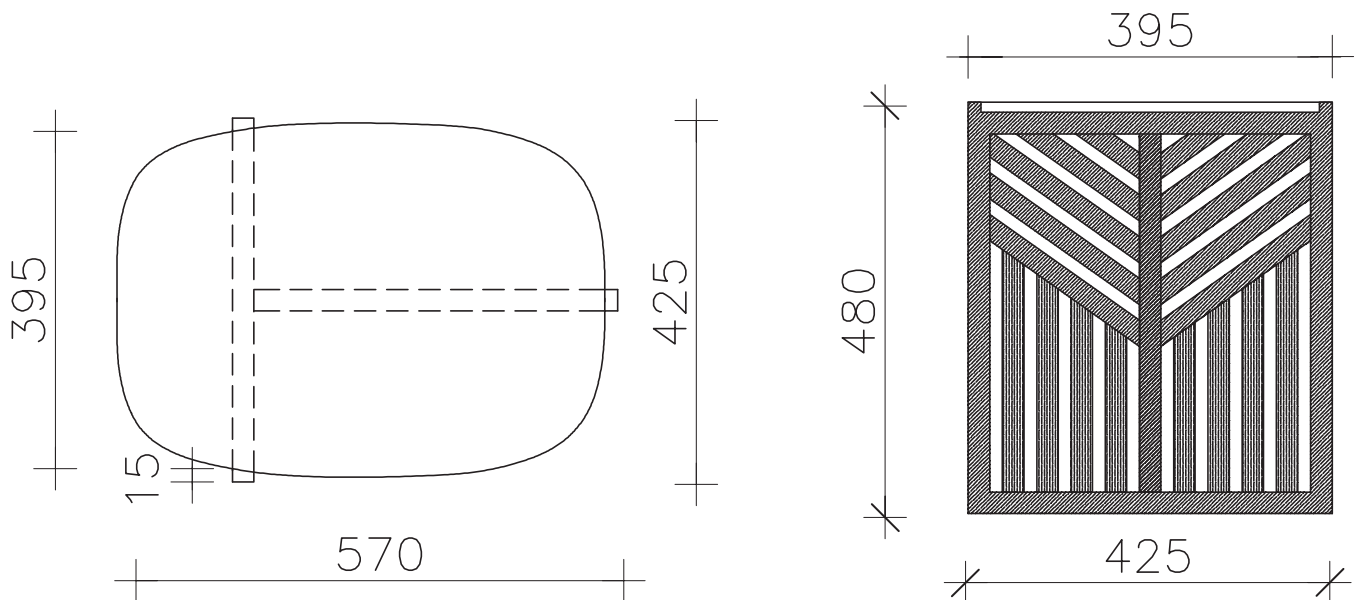

WOOD OPTIONS



Natural Oak

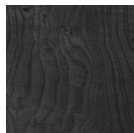

Carbon Oak



Chalked Oak

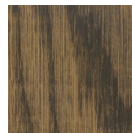

Dark Java Ash



Natural Ash

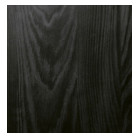

Carbon Ash



Walnut

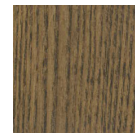

Dark Java Oak

DIMENSIONS

570W x 425L x 480H mm

WEIGHT

12 kg unboxed

DESCRIPTION

Clear or tinted glass top. Timber base available in a variety of finishes

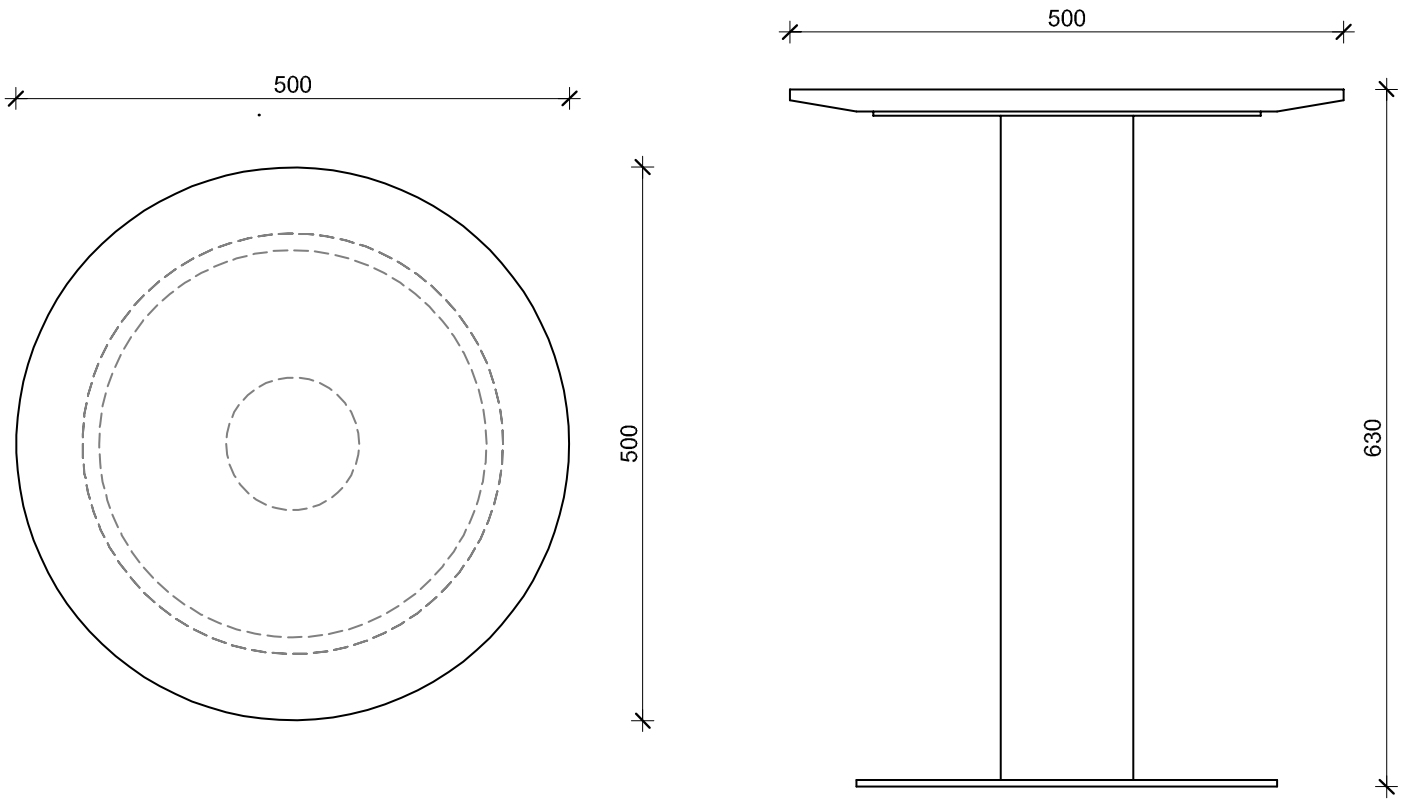

DIMENSIONS

500D x 630H mm

DESCRIPTION

Powdercoated Mild Steel Base with 20mm Granite/Marble Top of choice.

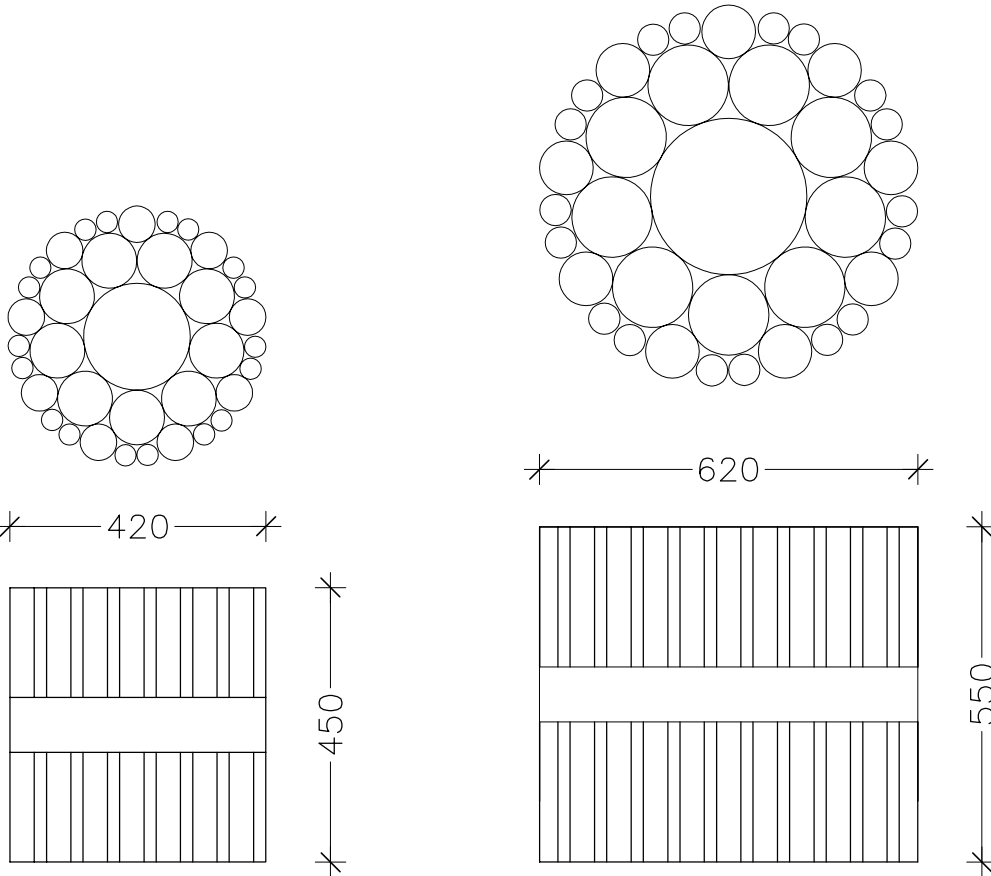

DIMENSIONS

SMALL: 420D x 450H mm

LARGE: 620D x 550H mm

DESCRIPTION

Naturally felled solid eucalyptus. Belt detail available in mirror polished steel, waxed mild steel, copper or brass.

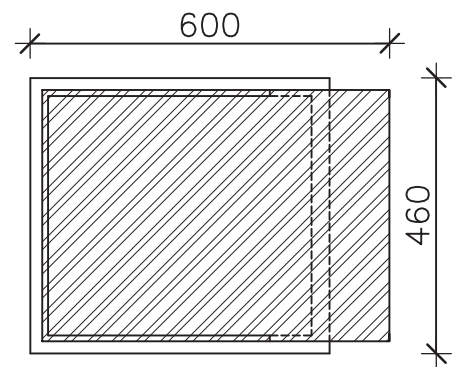
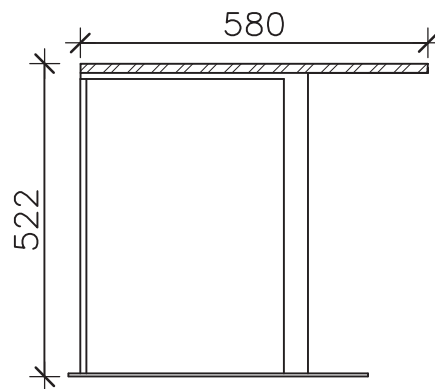
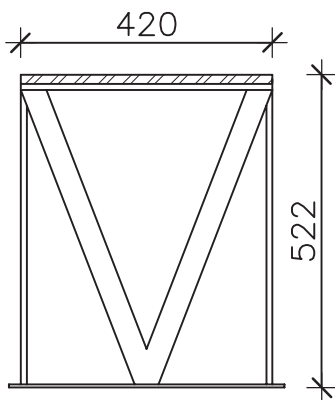

DIMENSIONS

580W x 460D x 522H mm

DESCRIPTION

Steel base with a variety of options.
Bronze and Grey Tinted Glass options available.

DESIGNED BY OKHA

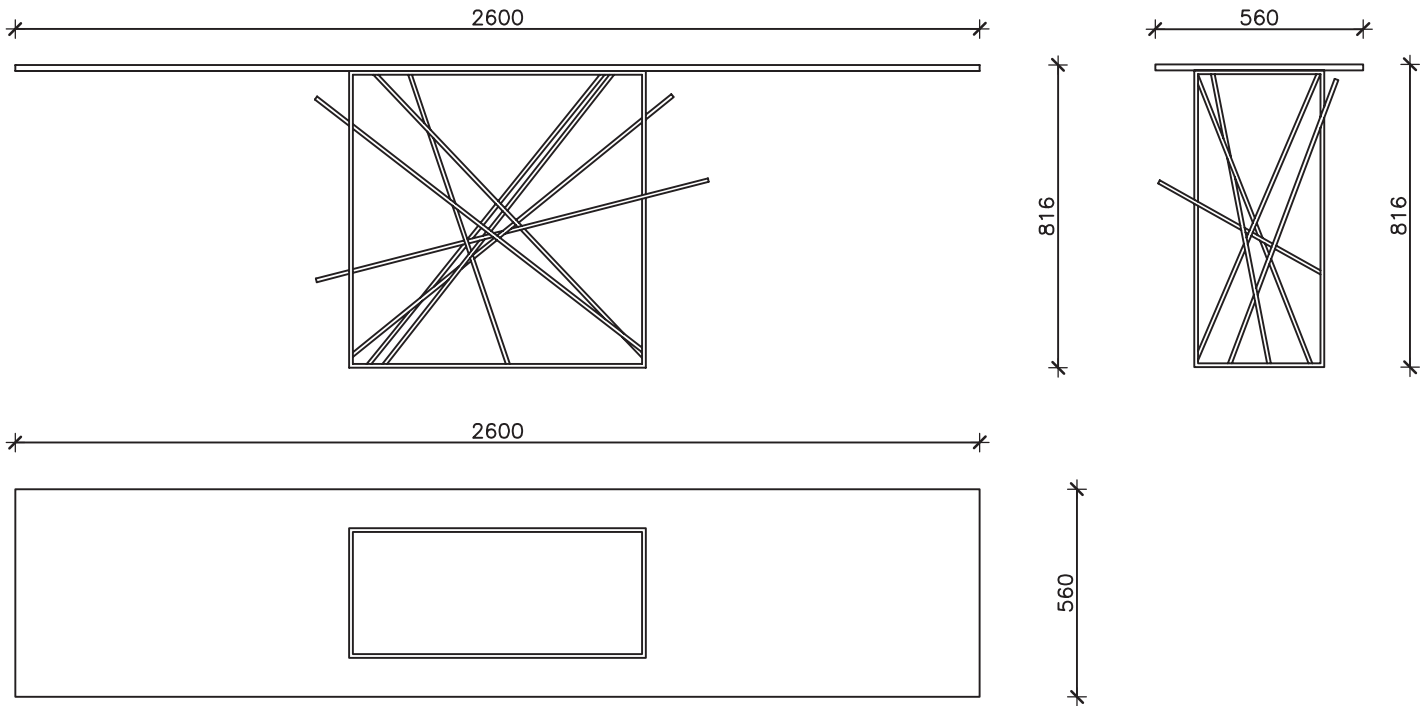
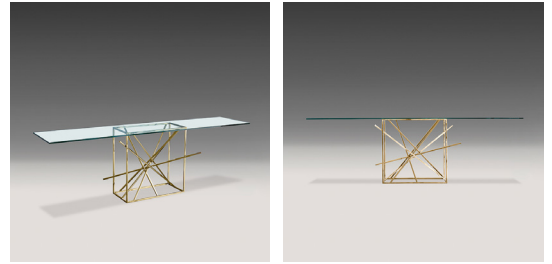

DIMENSIONS

2600W x 560D x 816H mm

DESCRIPTION

Bright polished brass base with a 16mm toughened clear glass top.

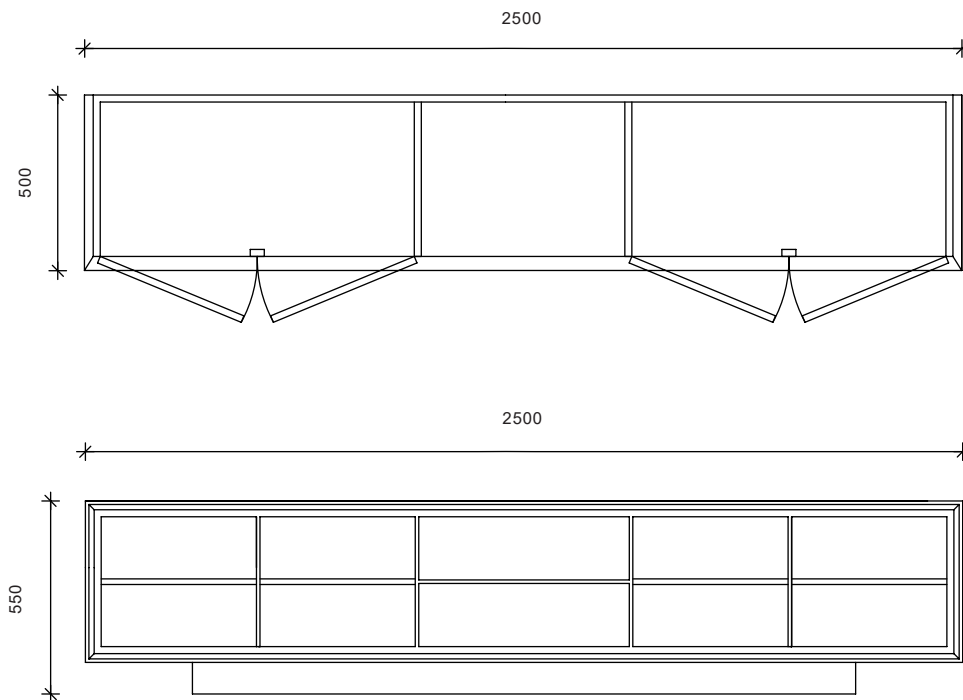
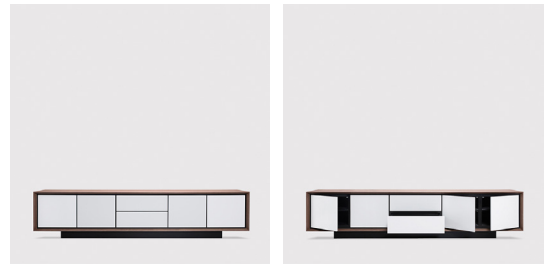

WOOD OPTIONS



Natural Oak

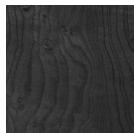

Carbon Oak



Chalked Oak

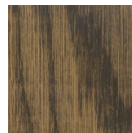

Dark Java Ash



Natural Ash

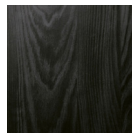

Carbon Ash



Walnut



Dark Java Oak

DIMENSIONS

2350W x 500D x 605H mm

DESCRIPTION

MDF construction body, duco door fronts and interior, wood veneer surround.

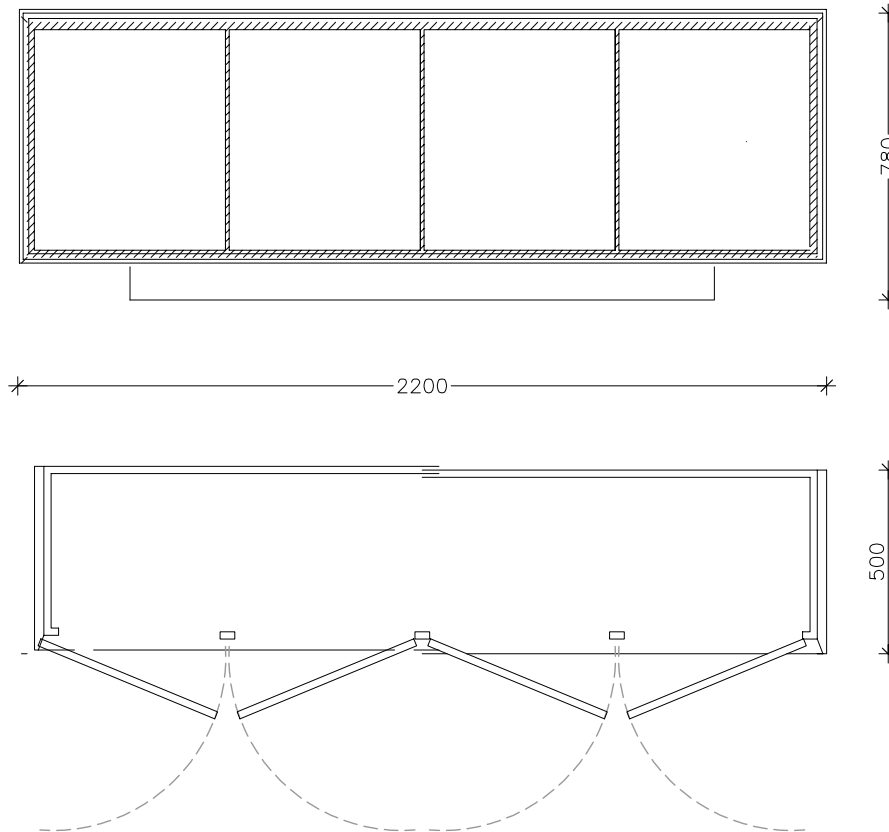

WOOD OPTIONS



Natural Oak



Carbon Oak



Chalked Oak

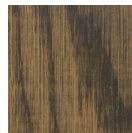

Dark Java Ash



Natural Ash



Carbon Ash



Walnut

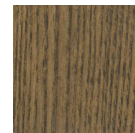

Dark Java Oak

DIMENSIONS

2235W x 500D x 780H mm

DESCRIPTION

Solid wood frame construction, MDF inner frame construction with Duco finish, and solid Brass feet.

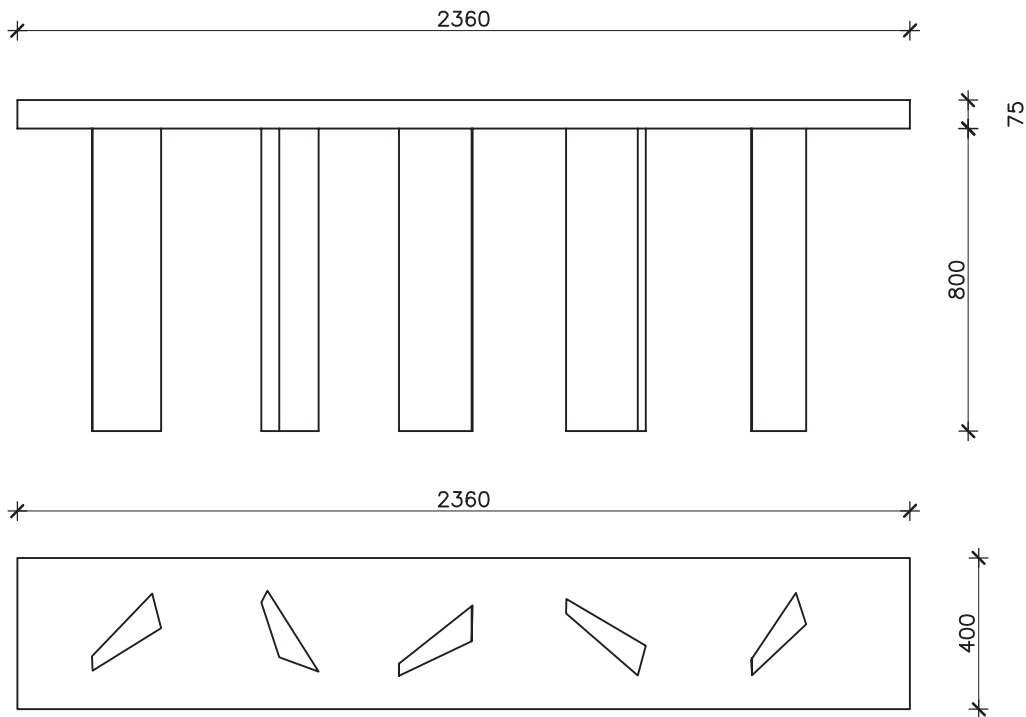

WOOD OPTIONS



Natural Oak

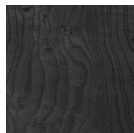

Carbon Oak



Chalked Oak

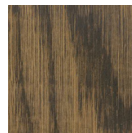

Dark Java Ash



Natural Ash

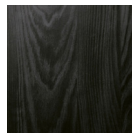

Carbon Ash



Walnut

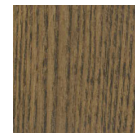

Dark Java Oak

DIMENSIONS

2360W x 400D x 875H mm

DESCRIPTION

5 x Raw mild steel bases with a Panga Panga timber top.
Base options: black or white mild steel.

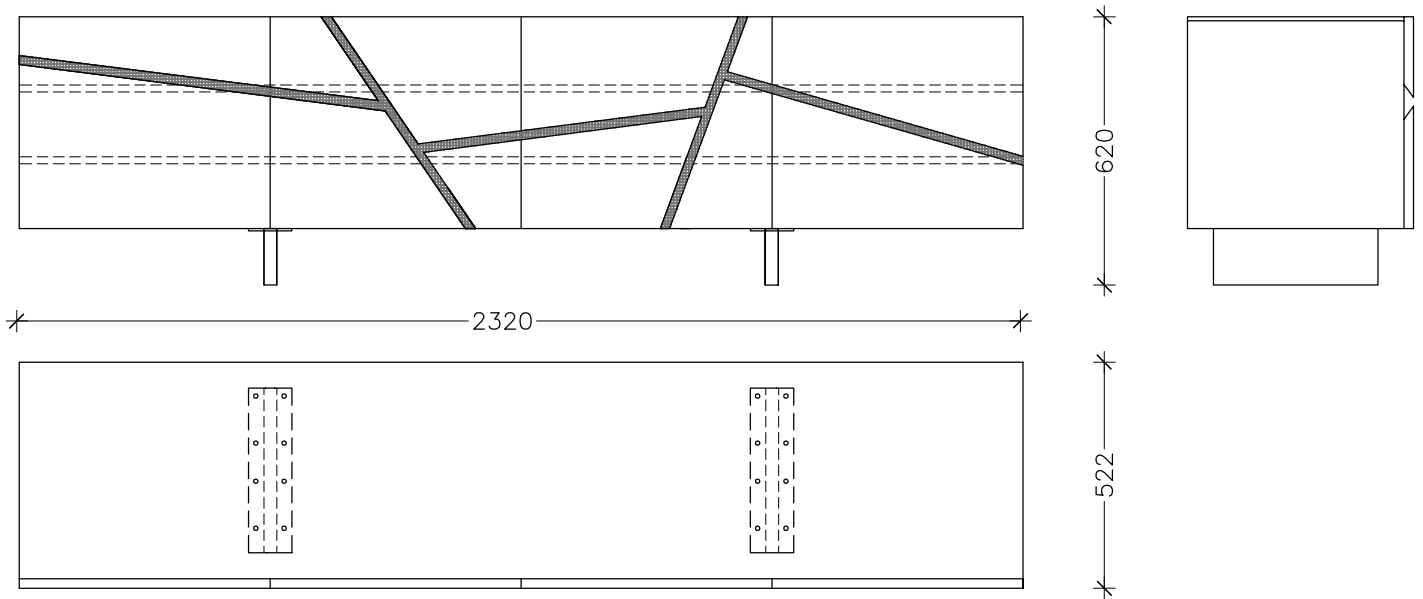

DIMENSIONS

2320W x 522D x 620H mm

DESCRIPTION

Mdf construction body, high gloss duco finish. Duco colour to client specification. Satin duco option available. Clear Perspex feet, interchangeable interior shelving. 10 mm Toughened tinted grey glass top with bright polished edges.

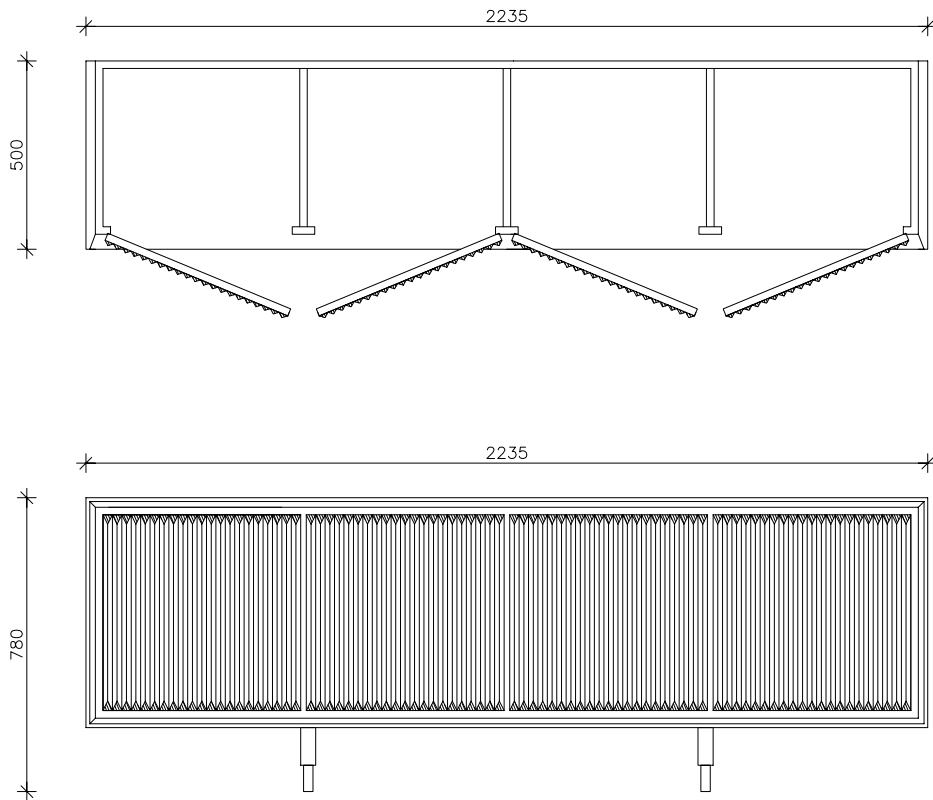

WOOD OPTIONS



Natural Oak

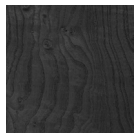

Carbon Oak



Chalked Oak

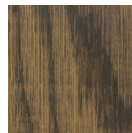

Dark Java Ash



Natural Ash



Carbon Ash



Walnut



Dark Java Oak

DIMENSIONS

2235W x 500D x 780H mm

DESCRIPTION

Solid wood frame construction with V-Groove detail to Door fronts, MDF inner frame construction with Duco finish, and solid Brass feet.

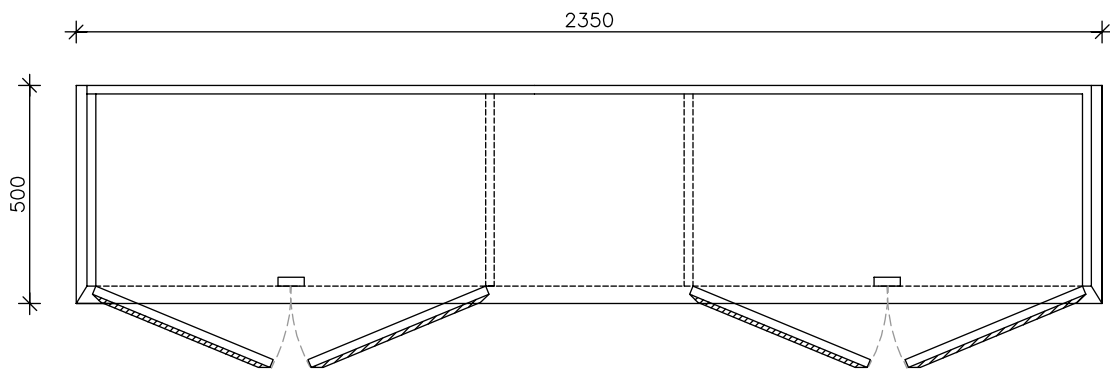
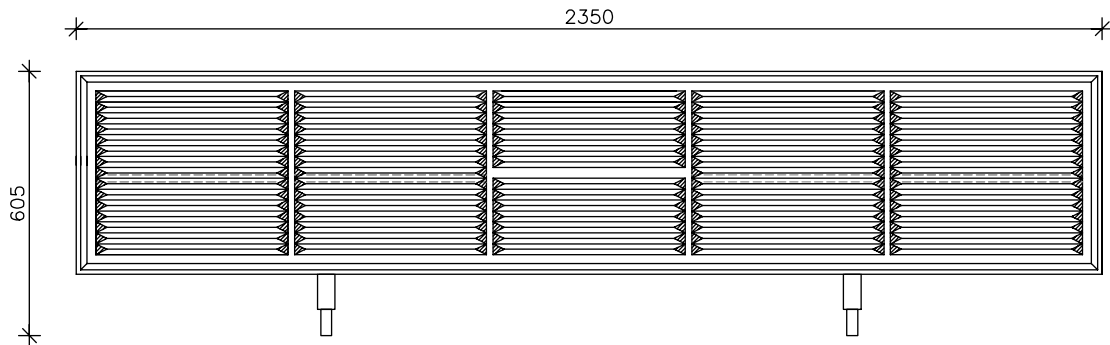

WOOD OPTIONS



Natural Oak

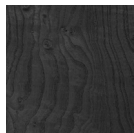

Carbon Oak



Chalked Oak

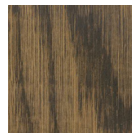

Dark Java Ash



Natural Ash

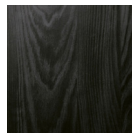

Carbon Ash



Walnut

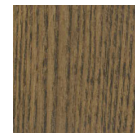

Dark Java Oak

DIMENSIONS

2350W x 500D x 605H mm

DESCRIPTION

Solid wood frame construction with V-Groove detail to Door and Drawer fronts, MDF inner frame construction with Duco finish, and solid Brass feet.

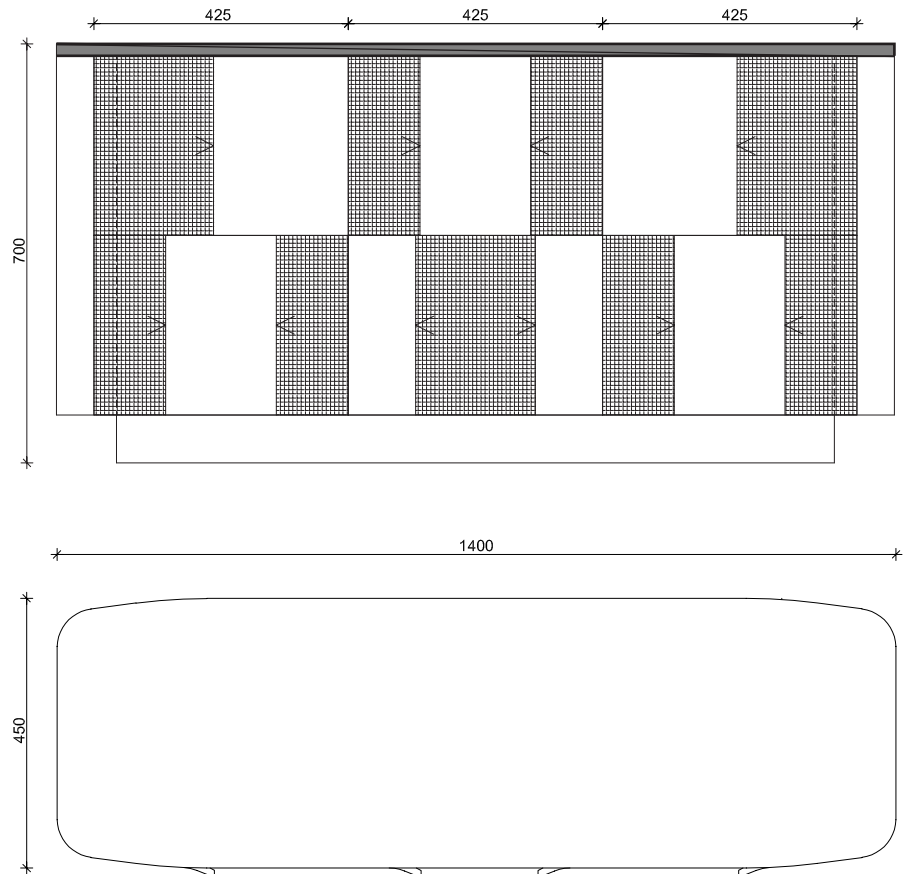
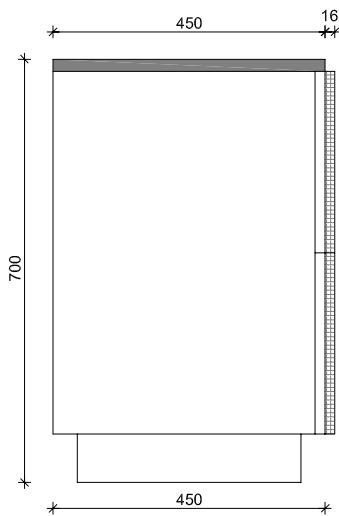

WOOD OPTIONS



Natural Oak

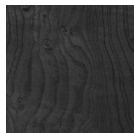

Carbon Oak



Chalked Oak

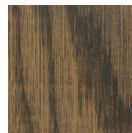

Dark Java Ash



Natural Ash



Carbon Ash



Walnut



Dark Java Oak

DIMENSIONS

1400W x 450D x 700H mm

DESCRIPTION

Veneered Oak Server with 6x Drawers with finger grip detail to drawer fronts, 30mm Beauty Dark Granite Top.

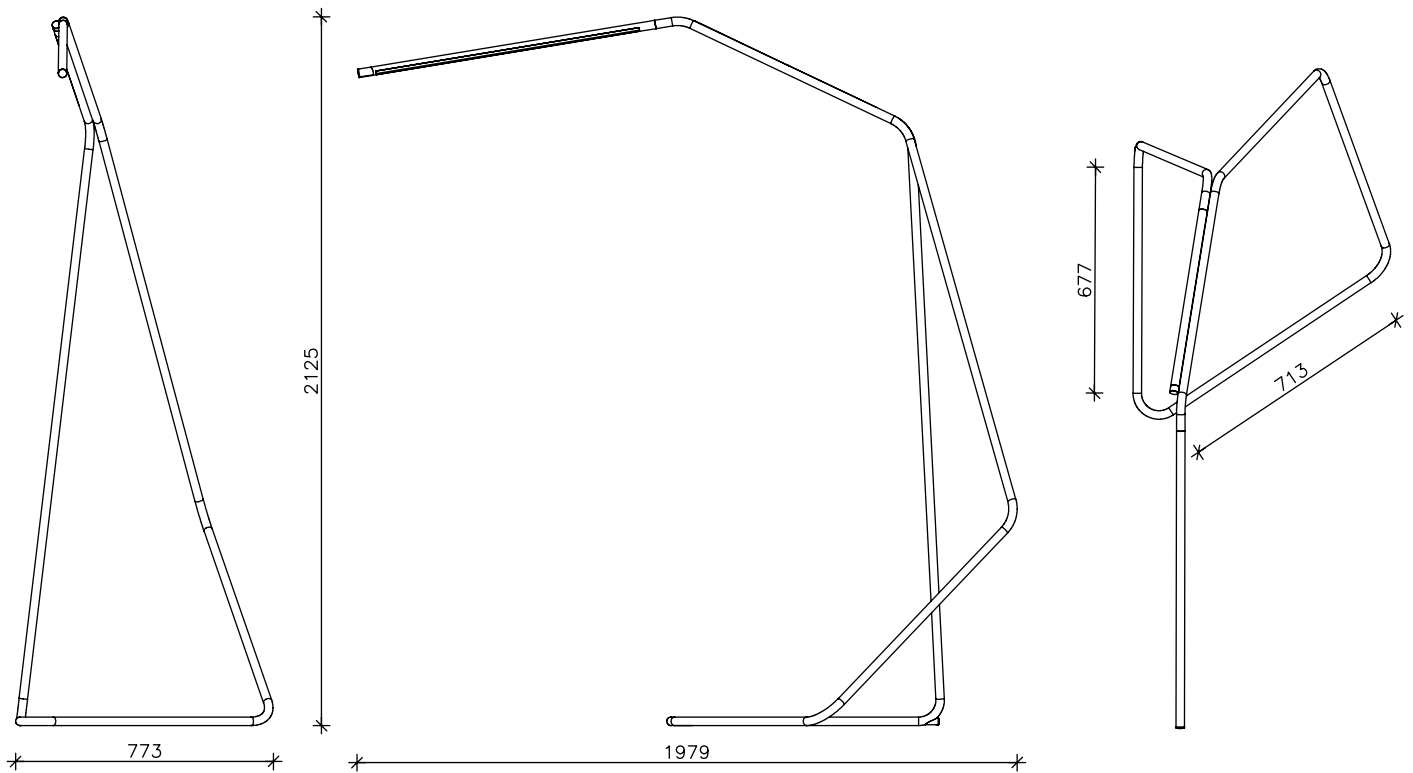

DIMENSIONS

1979W x 773D x 2125H mm

DESCRIPTION

Available in black or white powder coated finish.

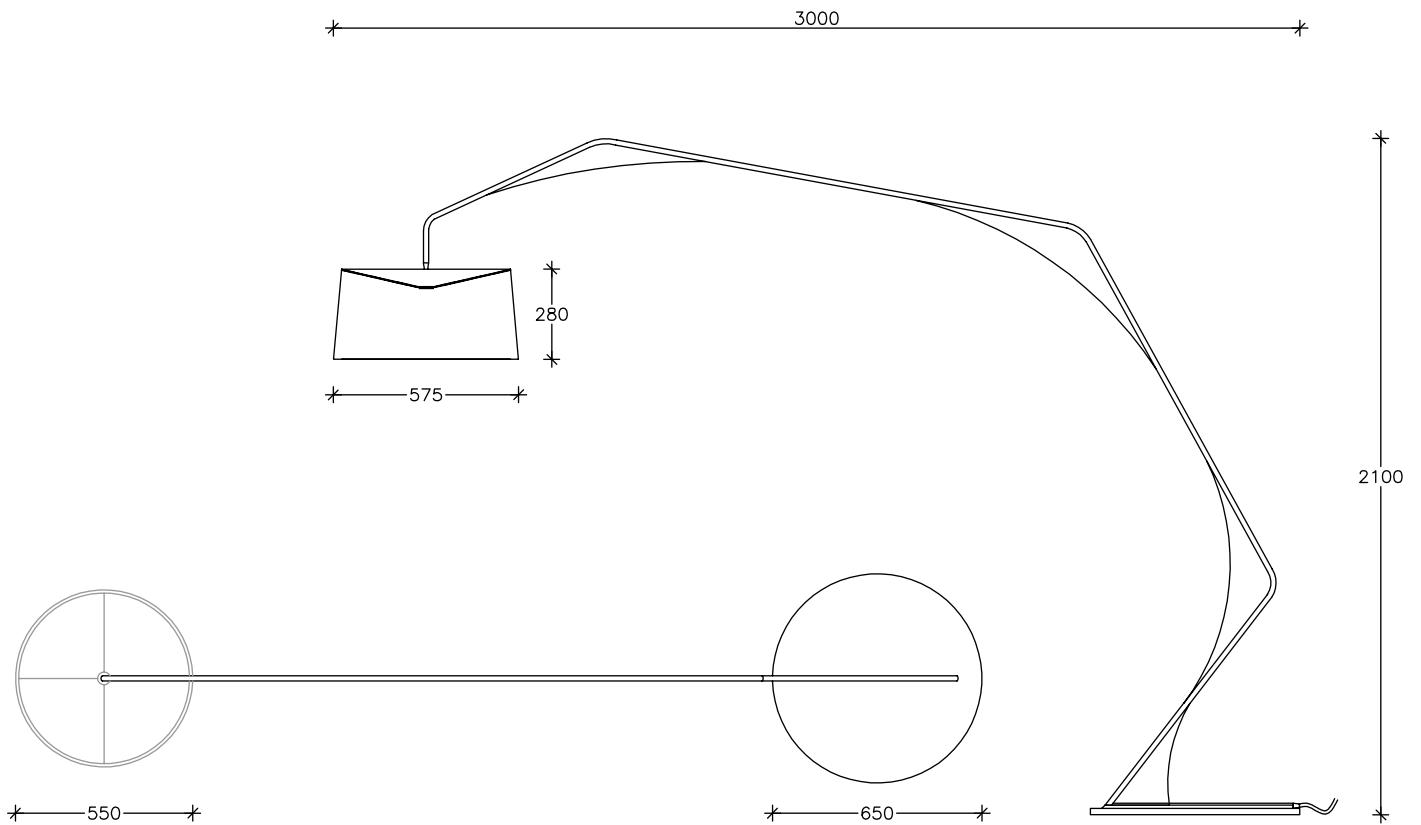

DIMENSIONS

3000W x 650D x 2100H mm - incl. shade

DESCRIPTION

Cantilevered structure available in black or white powder coat finish or mirror polished stainless steel. Dimmable foot switch. Cotton drum shade.

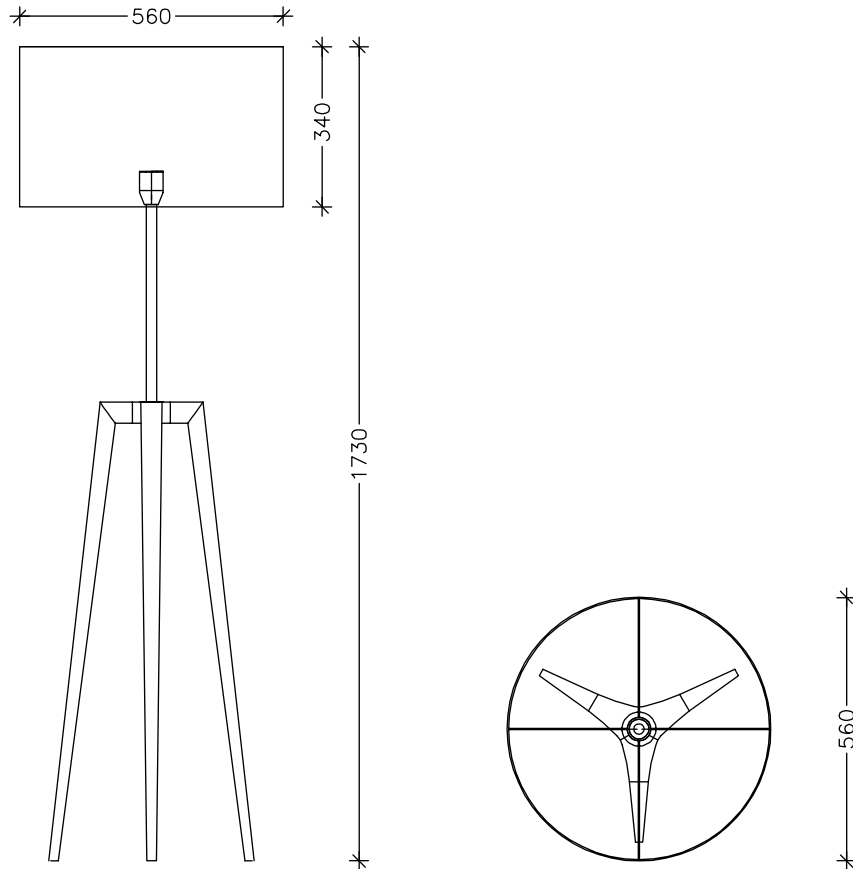

WOOD OPTIONS



Natural Oak



Carbon Oak



Chalked Oak

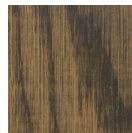

Dark Java Ash



Natural Ash



Carbon Ash



Walnut



Dark Java Oak

DIMENSIONS

560D x 1730H mm - incl. shade

DESCRIPTION

Naturally oiled solid walnut or oak base structure with Stainless Steel stem. Drum shaped cotton shade.

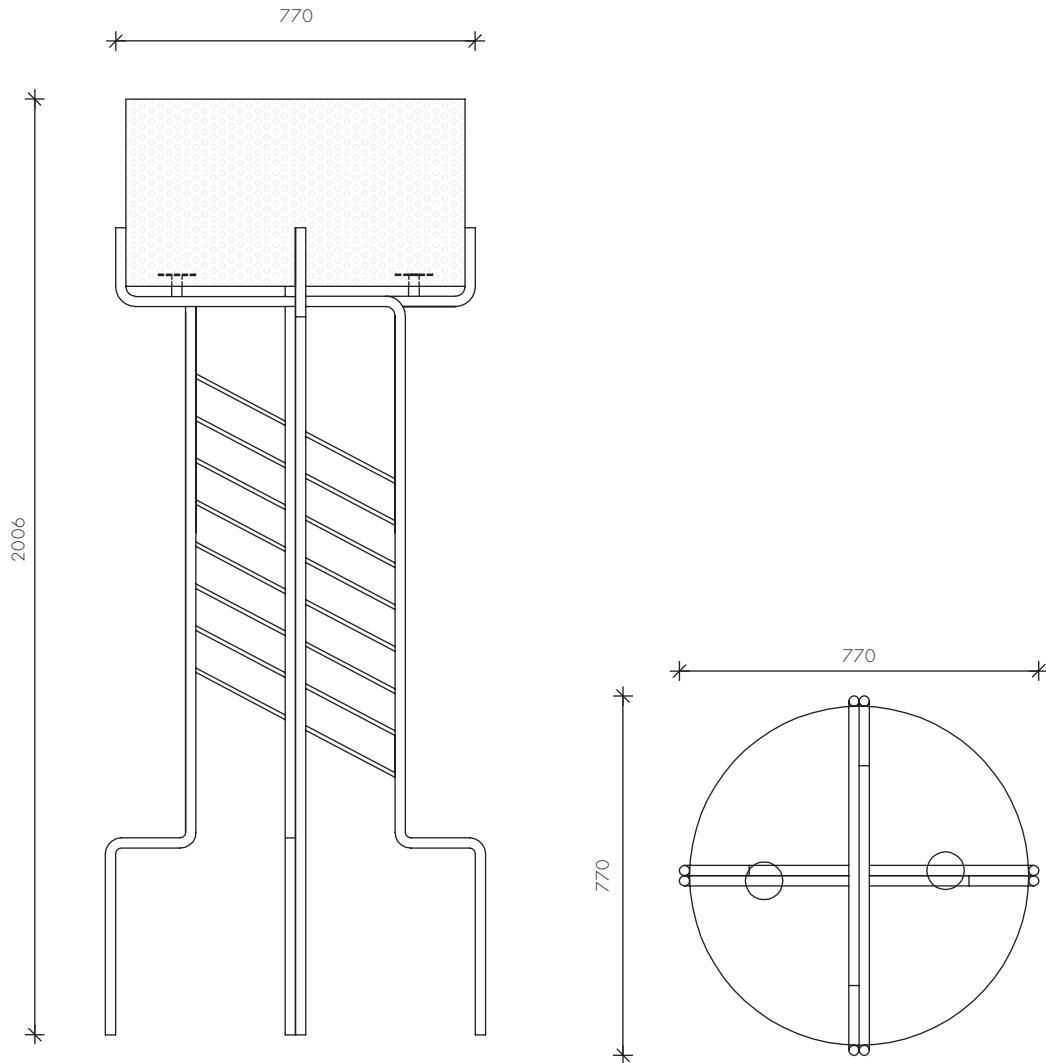

DIMENSIONS

770D x 2006H mm - incl. shade

DESCRIPTION

Powdercoated mild steel tube structure with perforated powdercoated aluminium drum shade, with a dimmable foot switch. Available in black or white powdercoated finish.

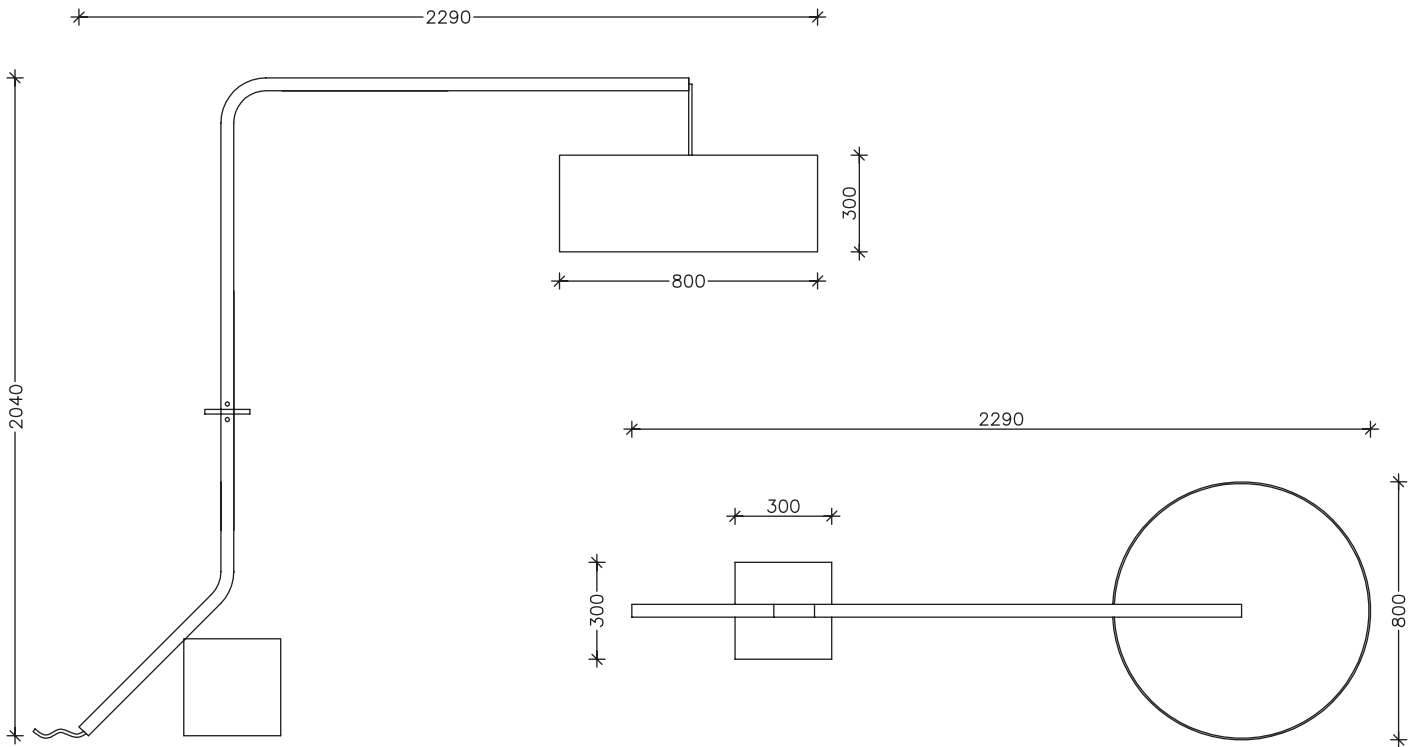

DIMENSIONS

2290W x 800D x 2040H - incl. shade

DESCRIPTION

40 mm Stainless steel counterweight and arm with a drum shaped cotton shade, available in black, white, grey or stone.

Available in black or white powdercoated finish.

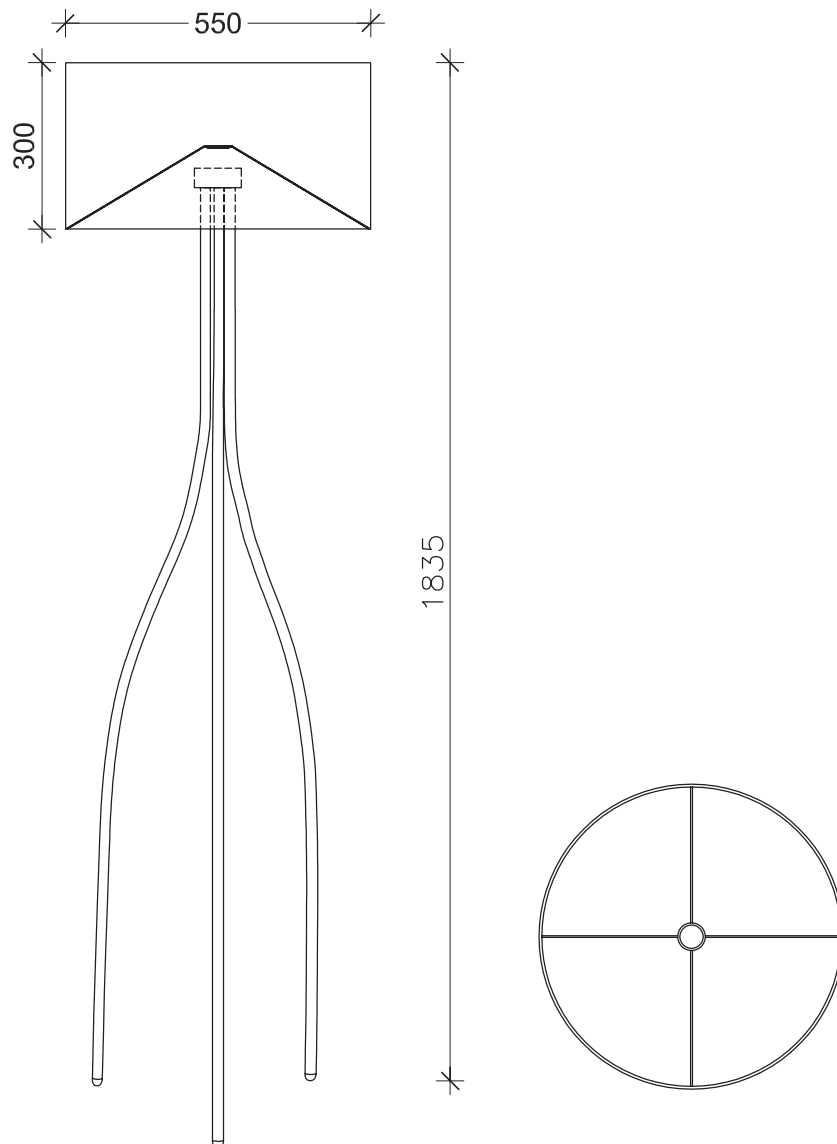

DIMENSIONS

550W x 1835D mm - incl. shade

DESCRIPTION

Powder coated steel tube base with drum shaped cotton shade.

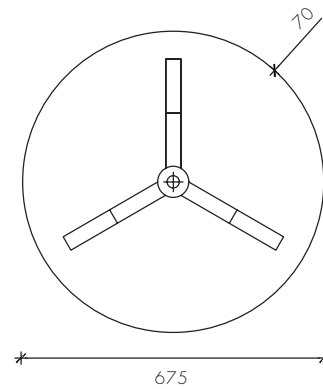
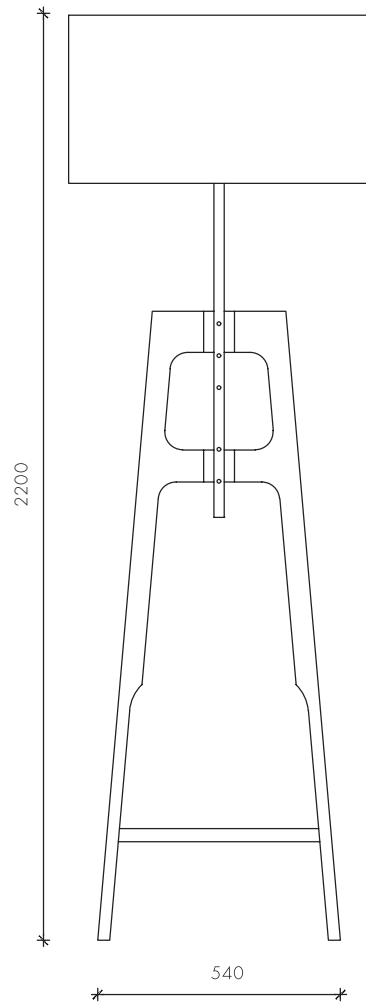

WOOD OPTIONS



Natural Oak

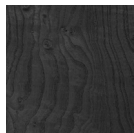

Carbon Oak



Chalked Oak

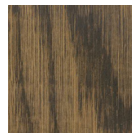

Dark Java Ash



Natural Ash



Carbon Ash



Walnut



Dark Java Oak

DIMENSIONS

540D x 1970 - 2200 H mm

675D mm Shade

DESCRIPTION

Adjustable height floor lamp. Solid oak base. Paper, linen or cotton shade.

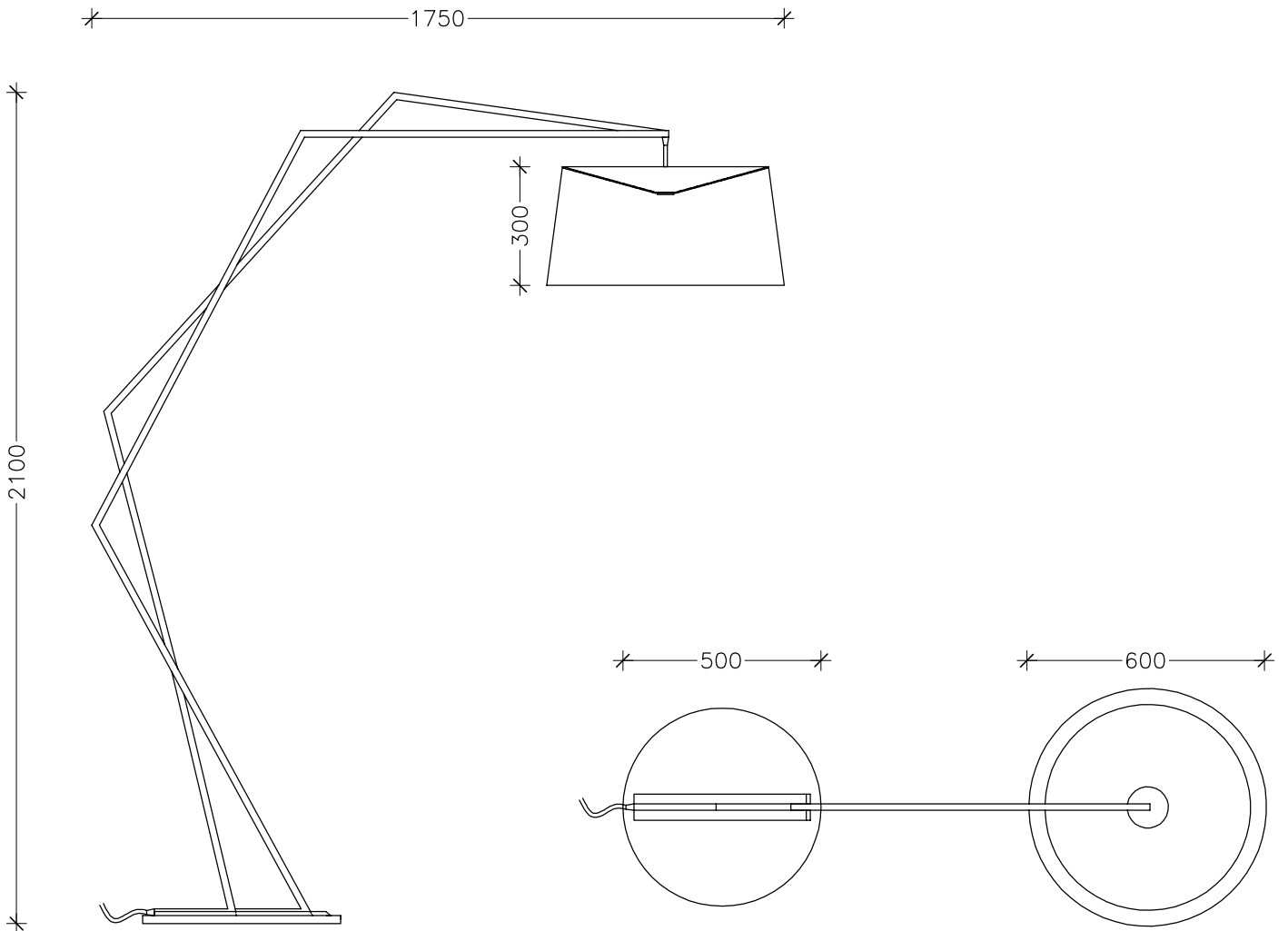

DIMENSIONS

1750W x 500D x 2100H mm - incl. shade
600D Shade

DESCRIPTION

Powder coated mild steel floor lamp available in black or white with a dimmable foot switch. Cotton drum shade.

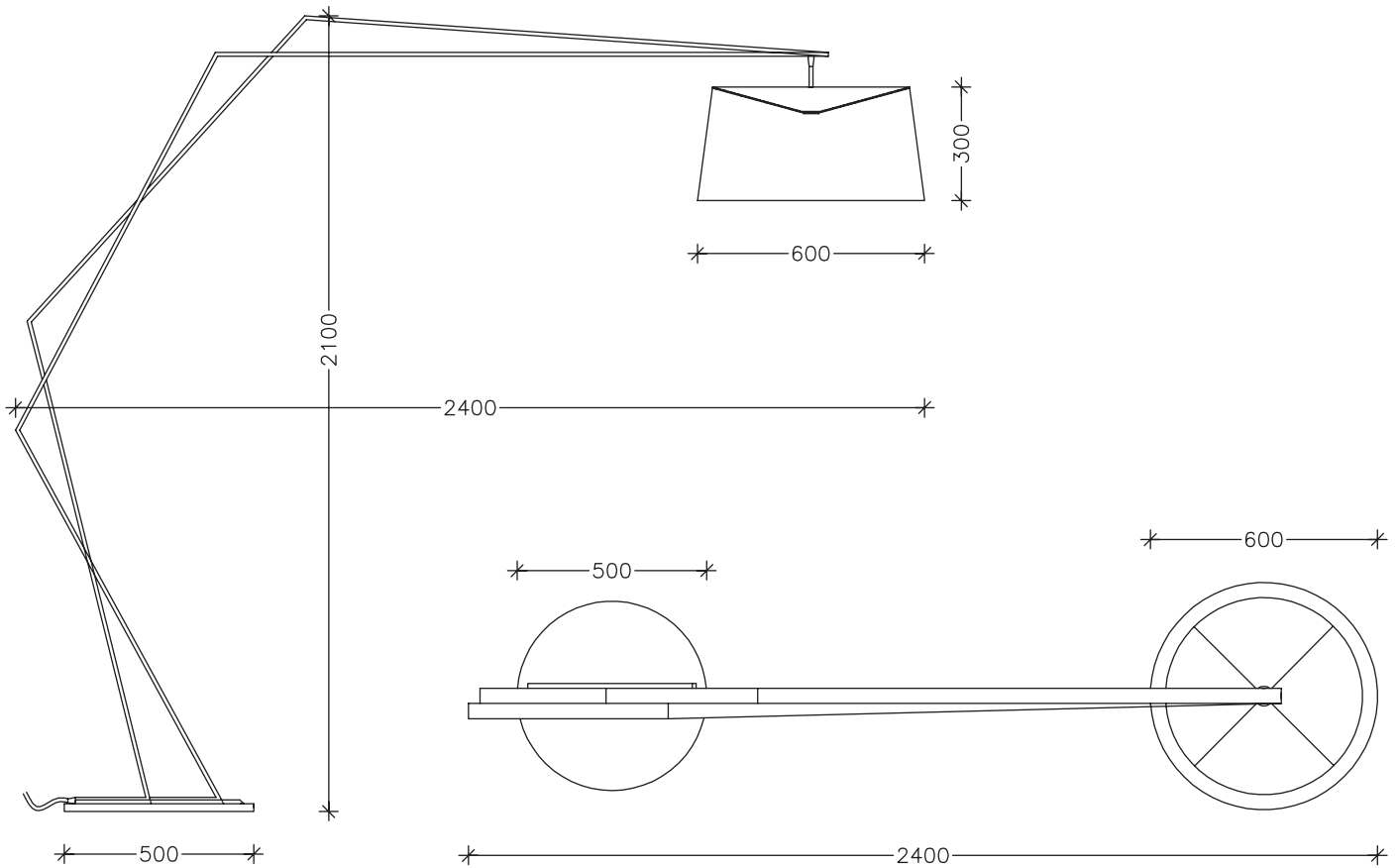

DIMENSIONS

2400W x 500D x 2100H mm - incl. shade

DESCRIPTION

Powder coated mild steel floor lamp available in black or white with a dimmable foot switch. Cotton drum shade.

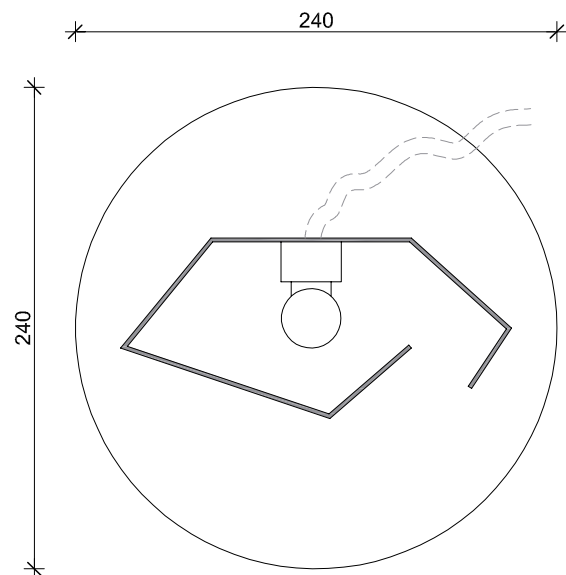
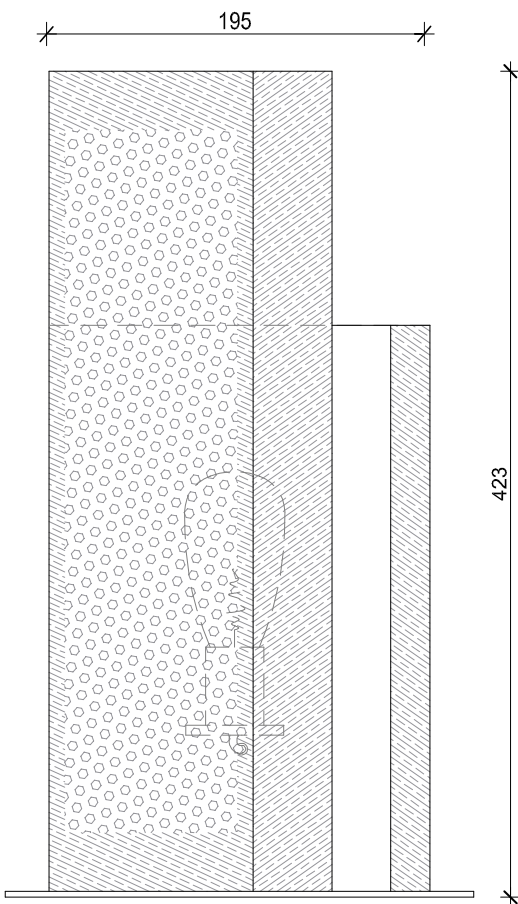
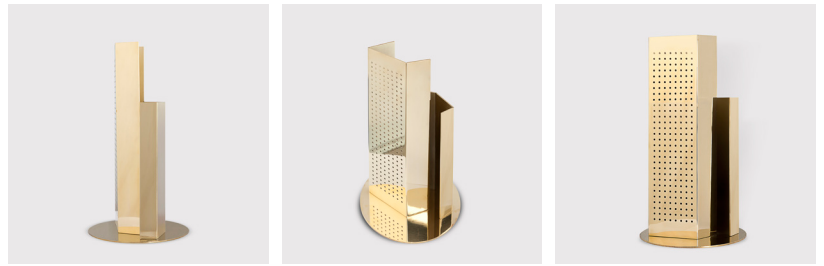

DIMENSIONS

195w x 100d x 290/420h with Baseplate 240DIA x 3d(mm)

DESCRIPTION

Mirror Polished base plate with Perforated Brass Shade.

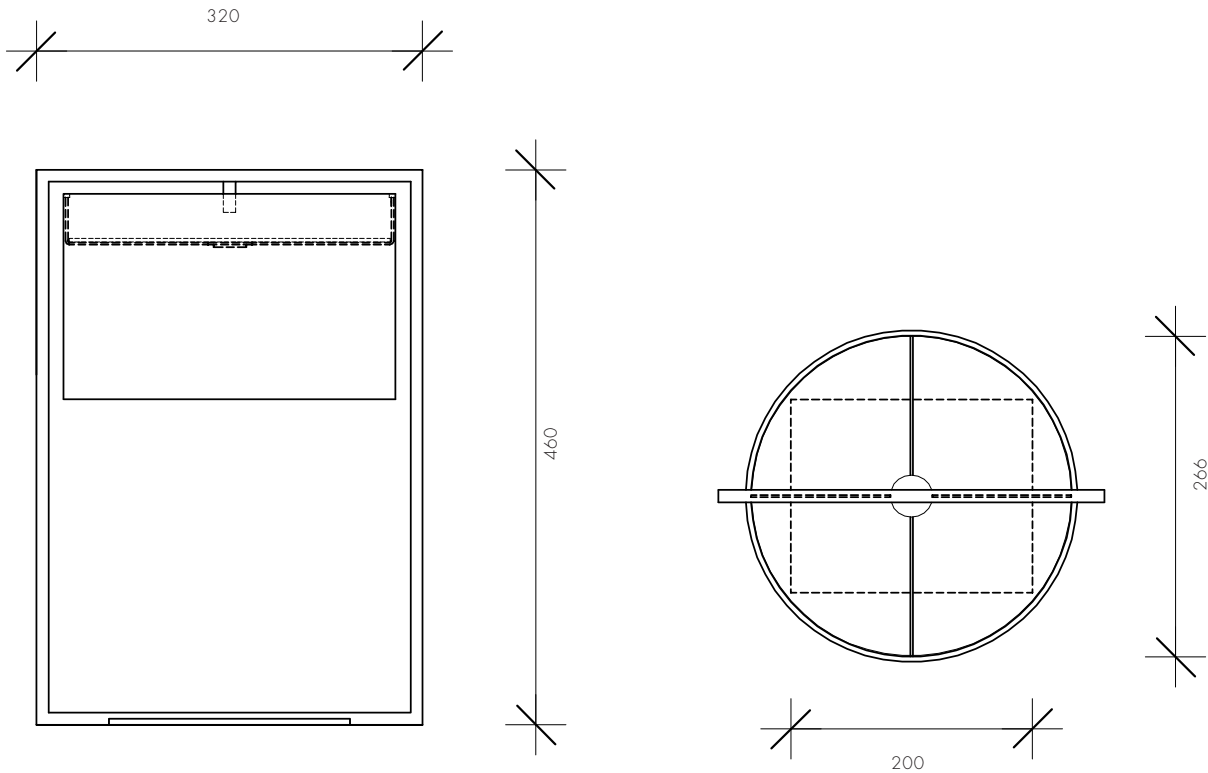

DIMENSIONS

320D x 460H mm - incl. shade

DESCRIPTION

Steel tube structure available in a black or white powder coat finish with a drum shaped cotton shade.

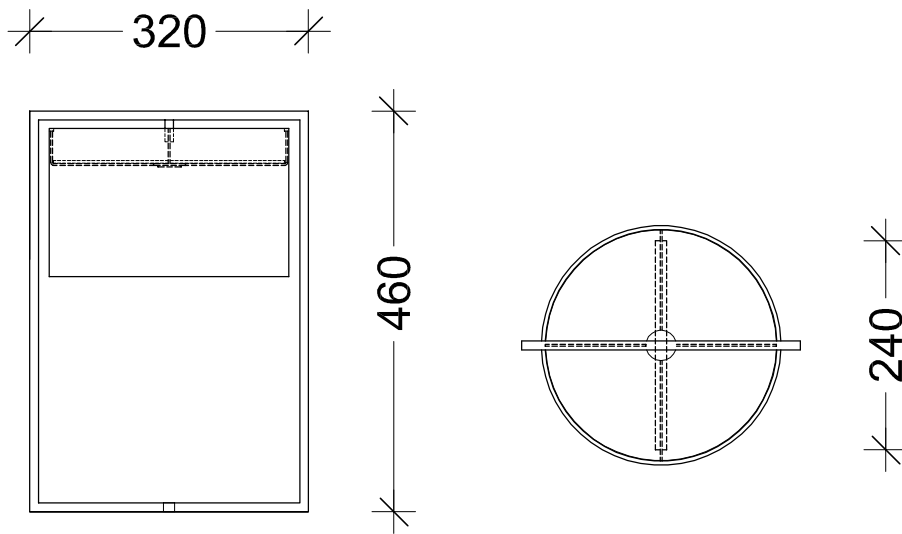

DIMENSIONS

320D x 460H mm - incl. shade

DESCRIPTION

Steel tube structure available in a black or white powder coat finish with a drum shaped cotton shade.

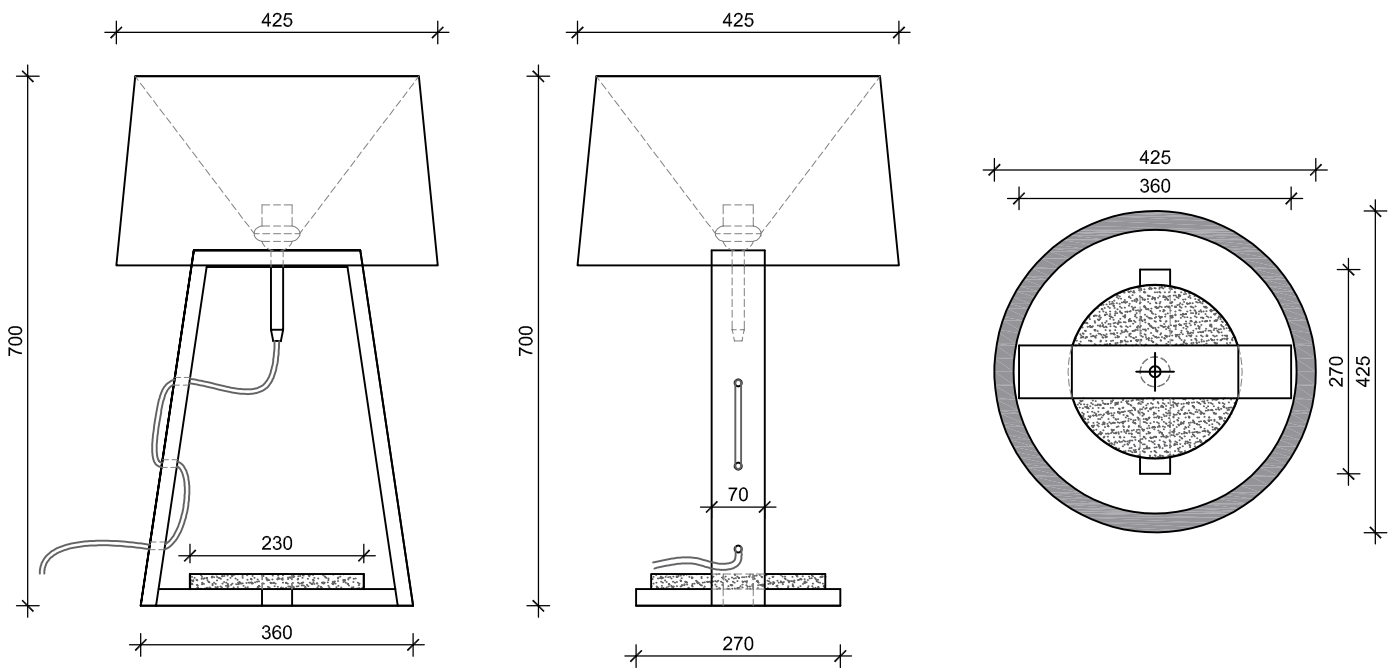

WOOD OPTIONS



Natural Oak

Carbon Oak

Chalked Oak

Dark Java Ash

Natural Ash

Carbon Ash

Walnut

Dark Java Oak

DIMENSIONS

425D x 700H mm

DESCRIPTION

Solid oak base. Paper, linen or cotton shade upon request. Marble disc.

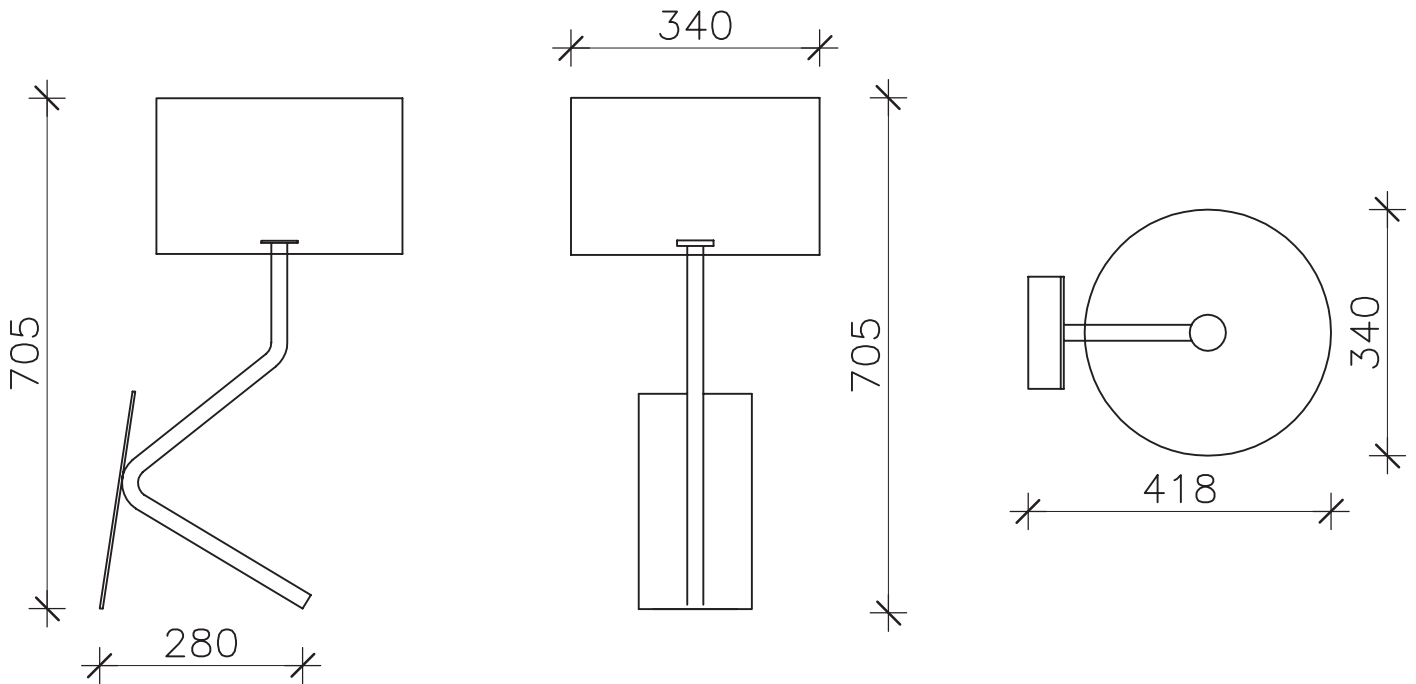

DIMENSIONS

418W x 340D x 705H mm - incl. shade

DESCRIPTION

Mirror polished stainless steel structure with a drum shaped cotton shade.

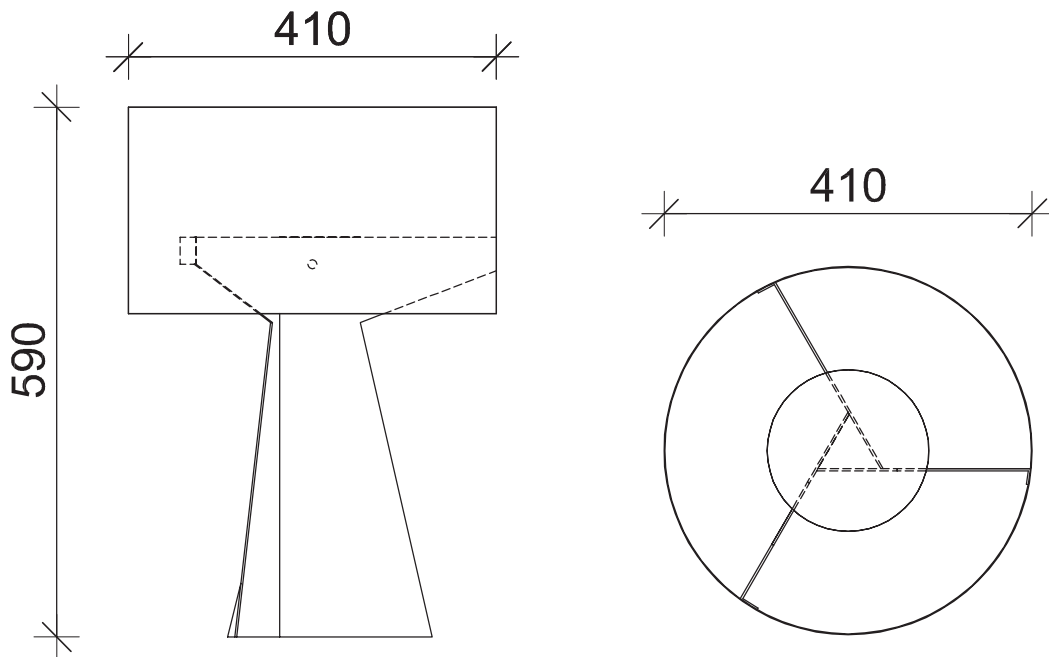

DIMENSIONS

410D x 590H mm - incl. shade

DESCRIPTION

Mirror polished stainless steel base and shade.

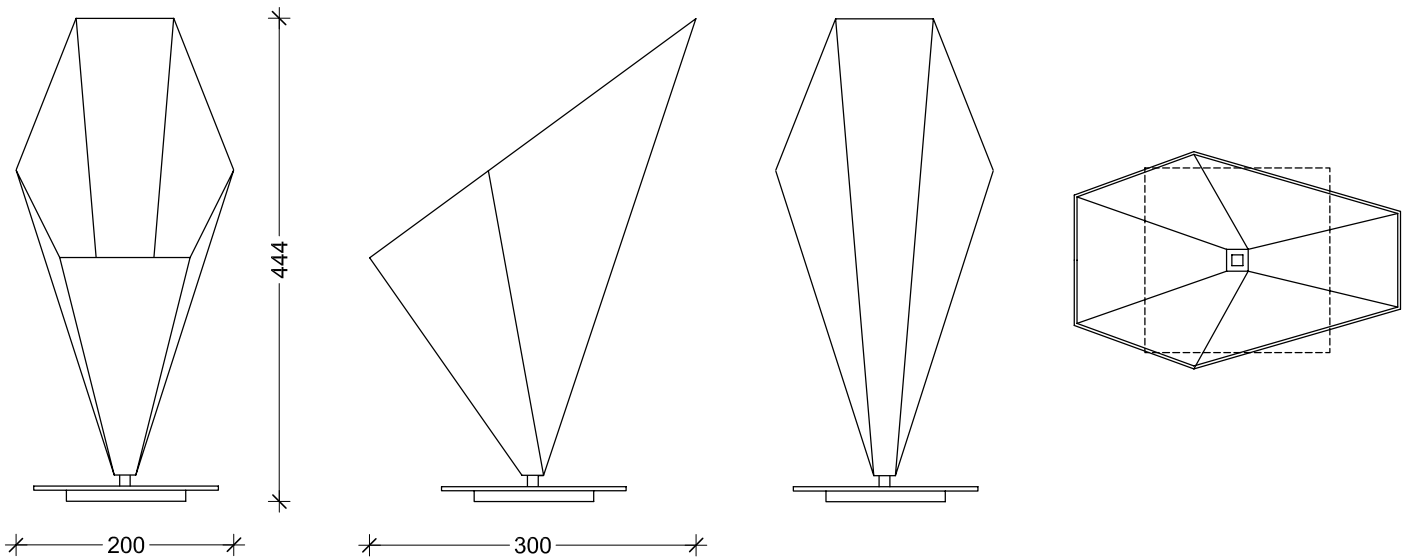

DIMENSIONS

200W x 300D x 444H mm

DESCRIPTION

Steel with perspex diffuser.



350

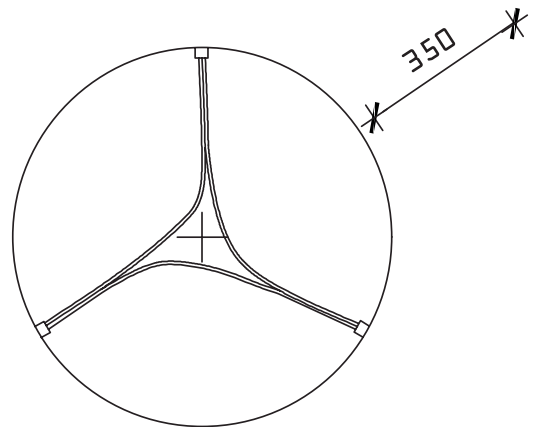
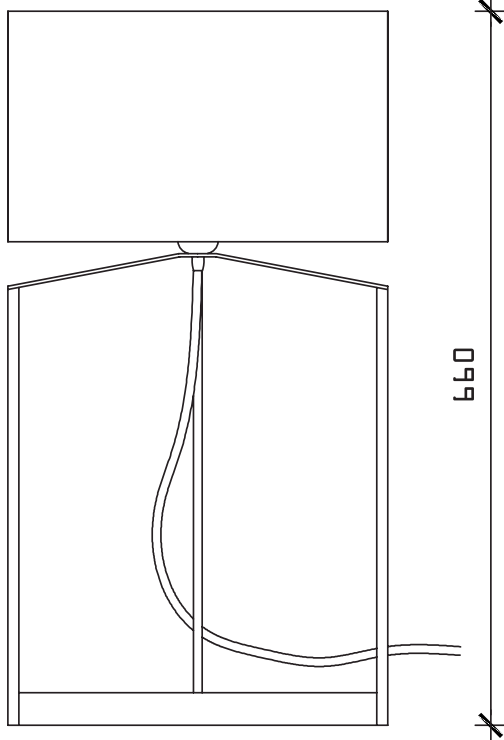

DIMENSIONS

350D x 660H mm

DESCRIPTION

Mirror polished stainless steel base, paper, linen or cotton shade.

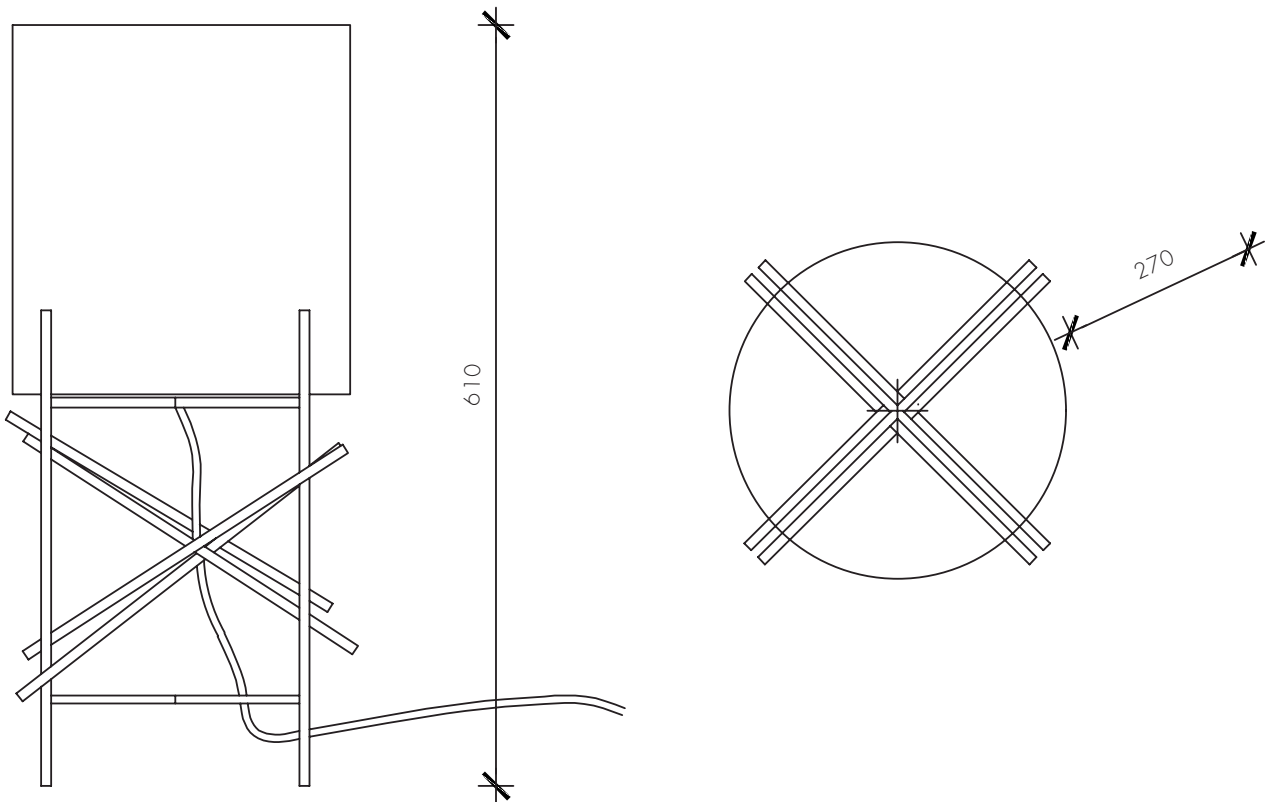
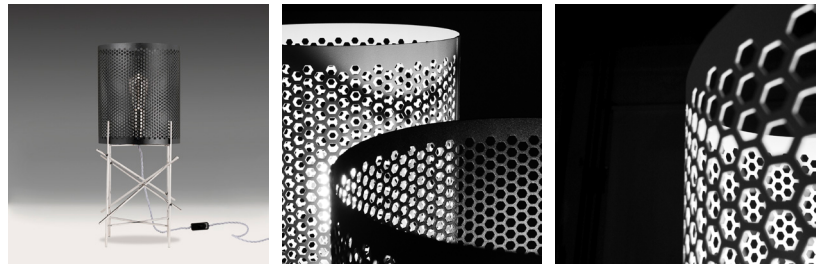

DIMENSIONS

270D x 610H mm

DESCRIPTION

Polished stainless steel base, powder coated metal shade in black or white matte finish.

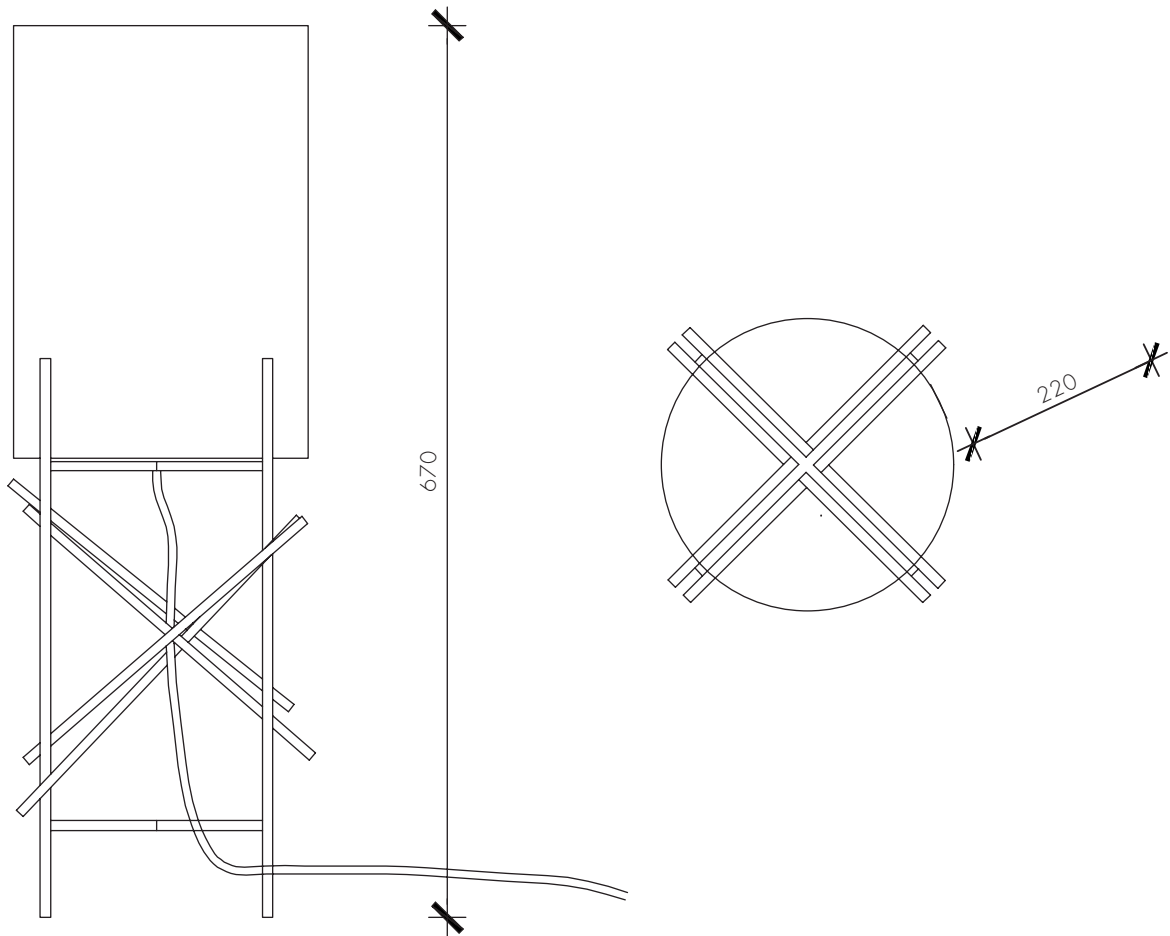
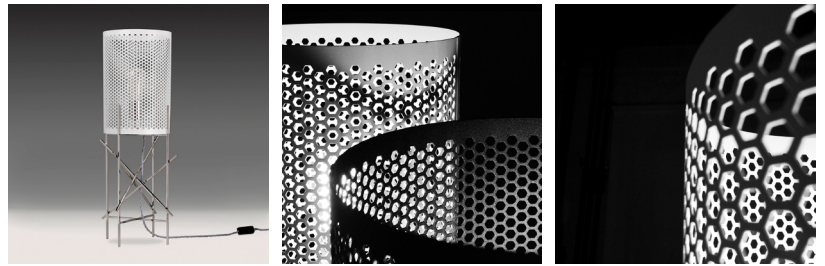

DIMENSIONS

220D x 670 H mm

DESCRIPTION

Polished stainless steel base, powder coated metal shade in black or white matte finish.

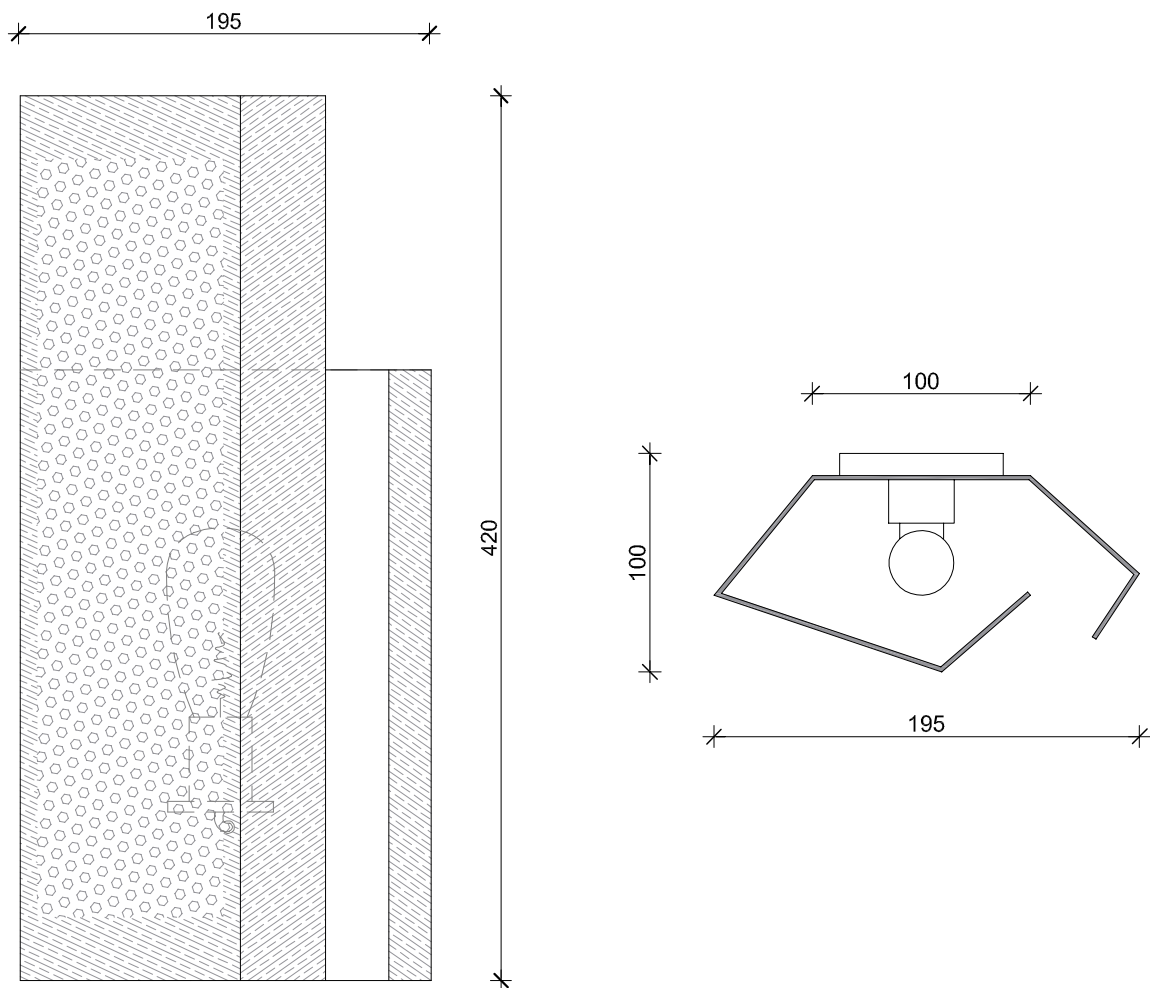

DIMENSIONS

195w x 100d x 290/420h (mm)

DESCRIPTION

Mirror Polished Brass Shade with Perforations. Black Stained Timber mounting block behind

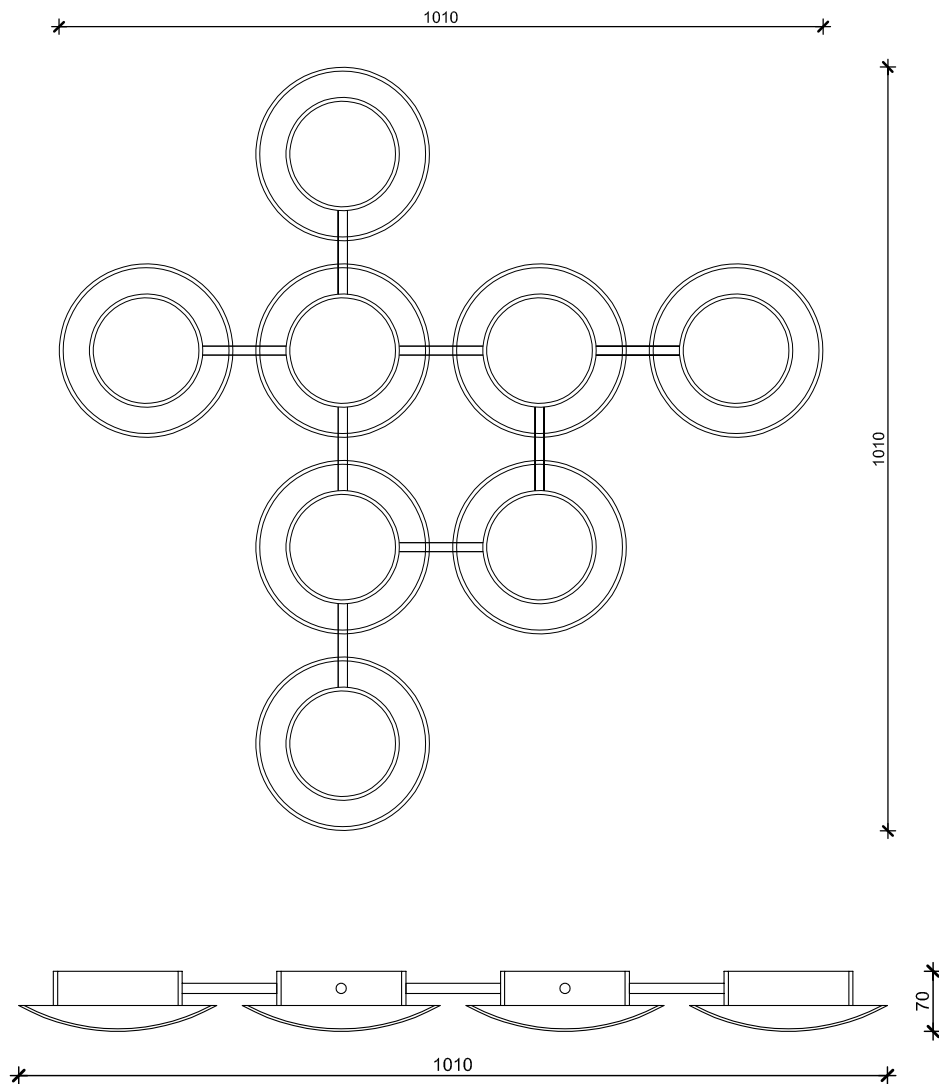

DIMENSIONS

Light Set 1: 1010w x 1010d x 70h (mm)

Light Set 1: 750w x 1010d x 70h (mm)

DESCRIPTION

Mirror Polished Brass Dome Clusters with LED Light fittings.

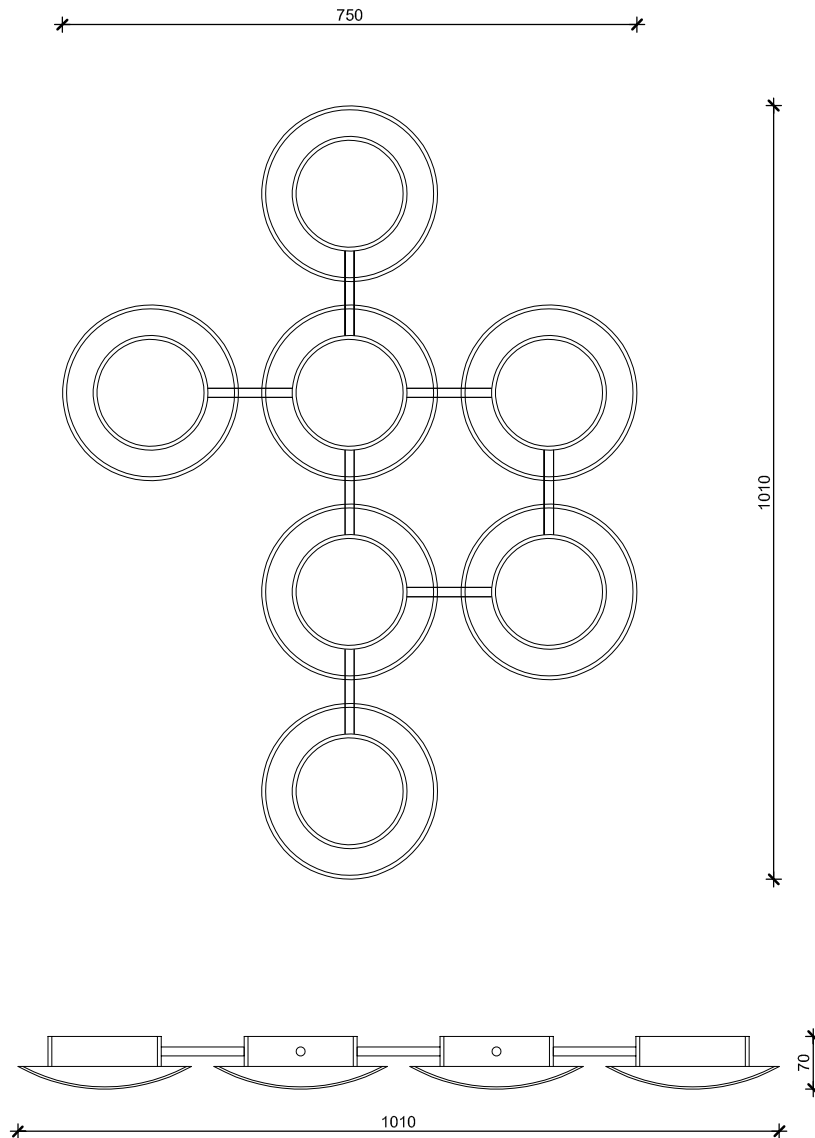

DIMENSIONS

Light Set 2: 1010w x 1010d x 70h (mm)

Light Set 2: 750w x 1010d x 70h (mm)

DESCRIPTION

Mirror Polished Brass Dome Clusters with LED Light fittings.

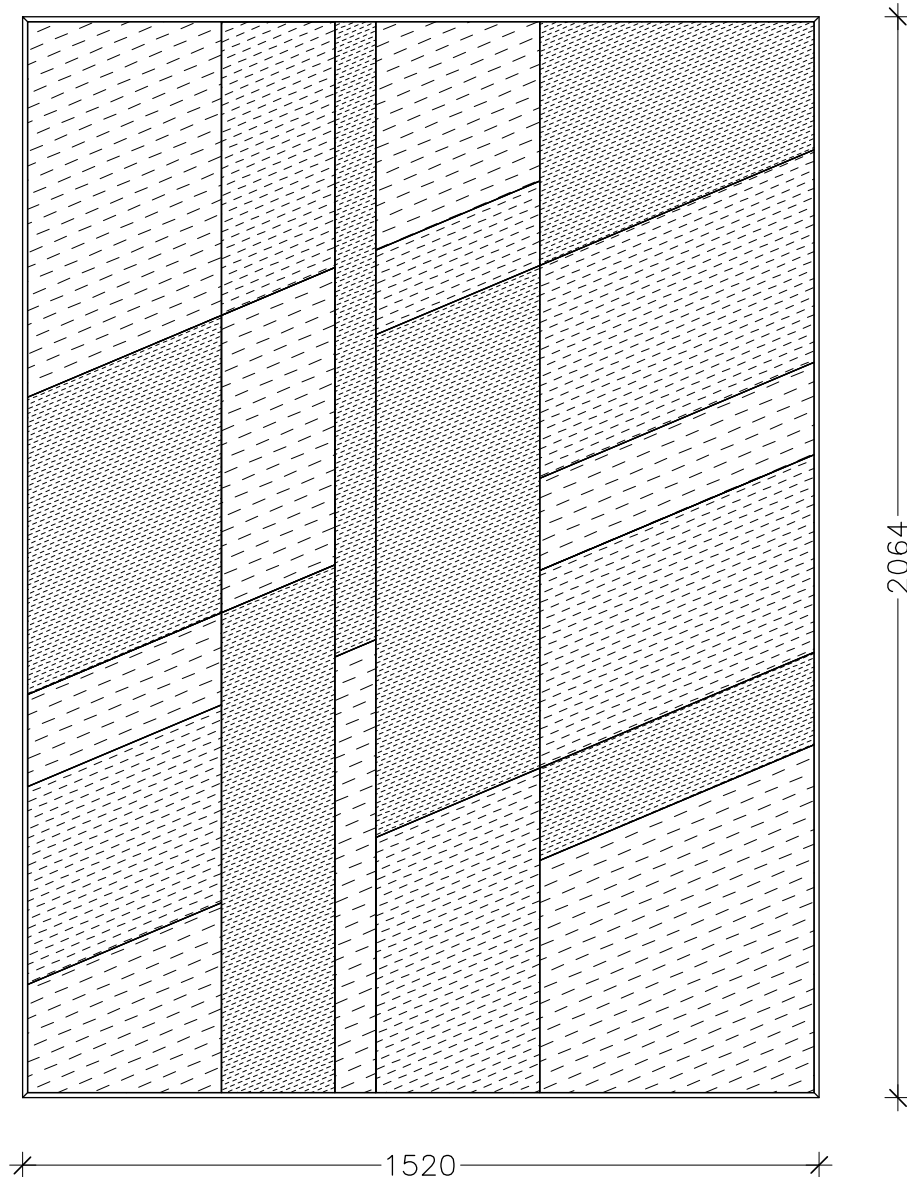
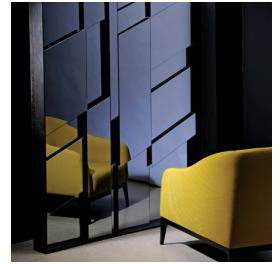

DIMENSIONS

1520W x 100D x 2064H mm

DESCRIPTION

Raw mild steel frame with recessed mirrors available in clear, grey or bronze tint.

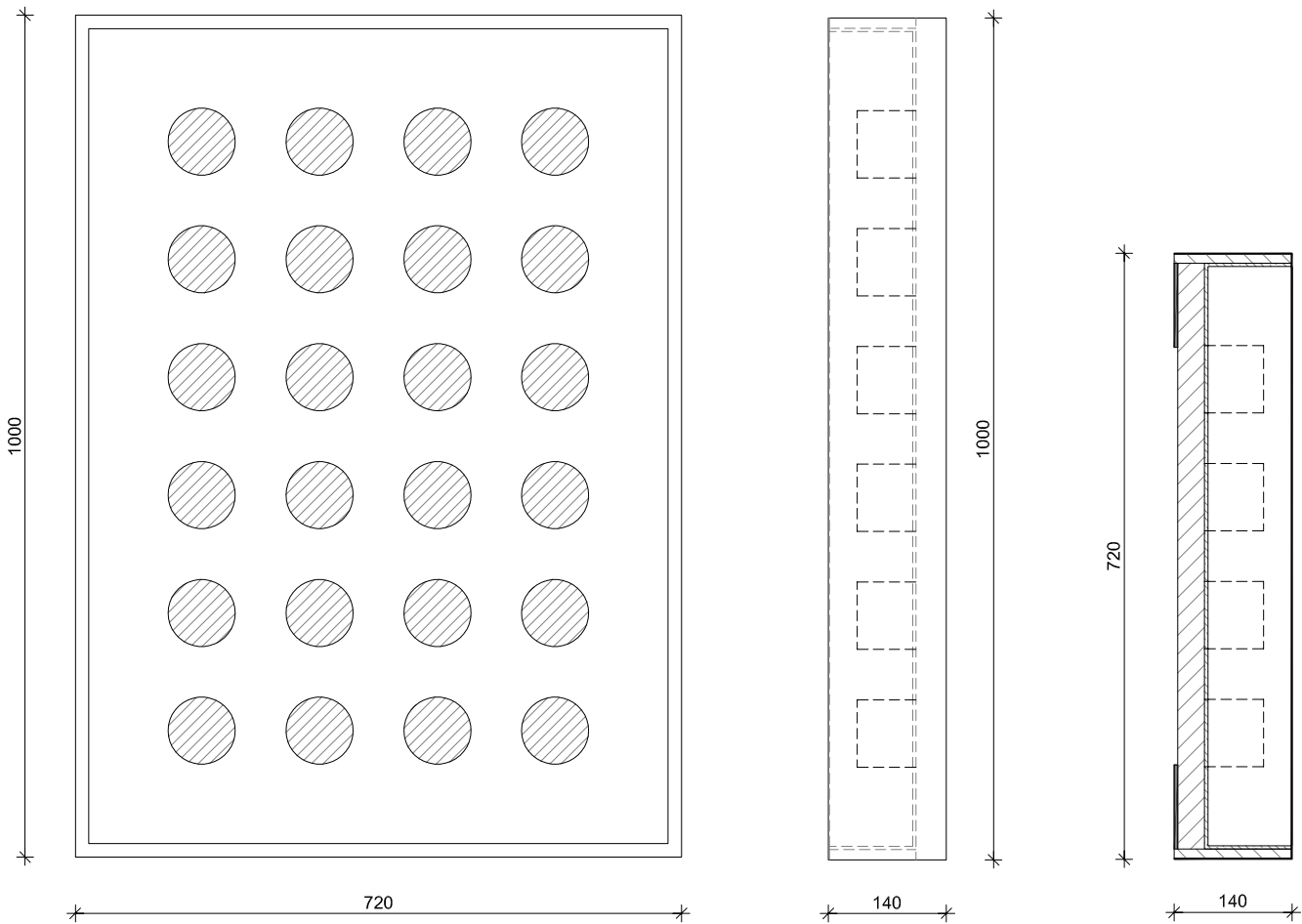

DIMENSIONS

720W x 140D x 1000H mm

DESCRIPTION

Mirror Polished Copper frame and cylinders with closed tops and SP
Blackened Grey Glass backing

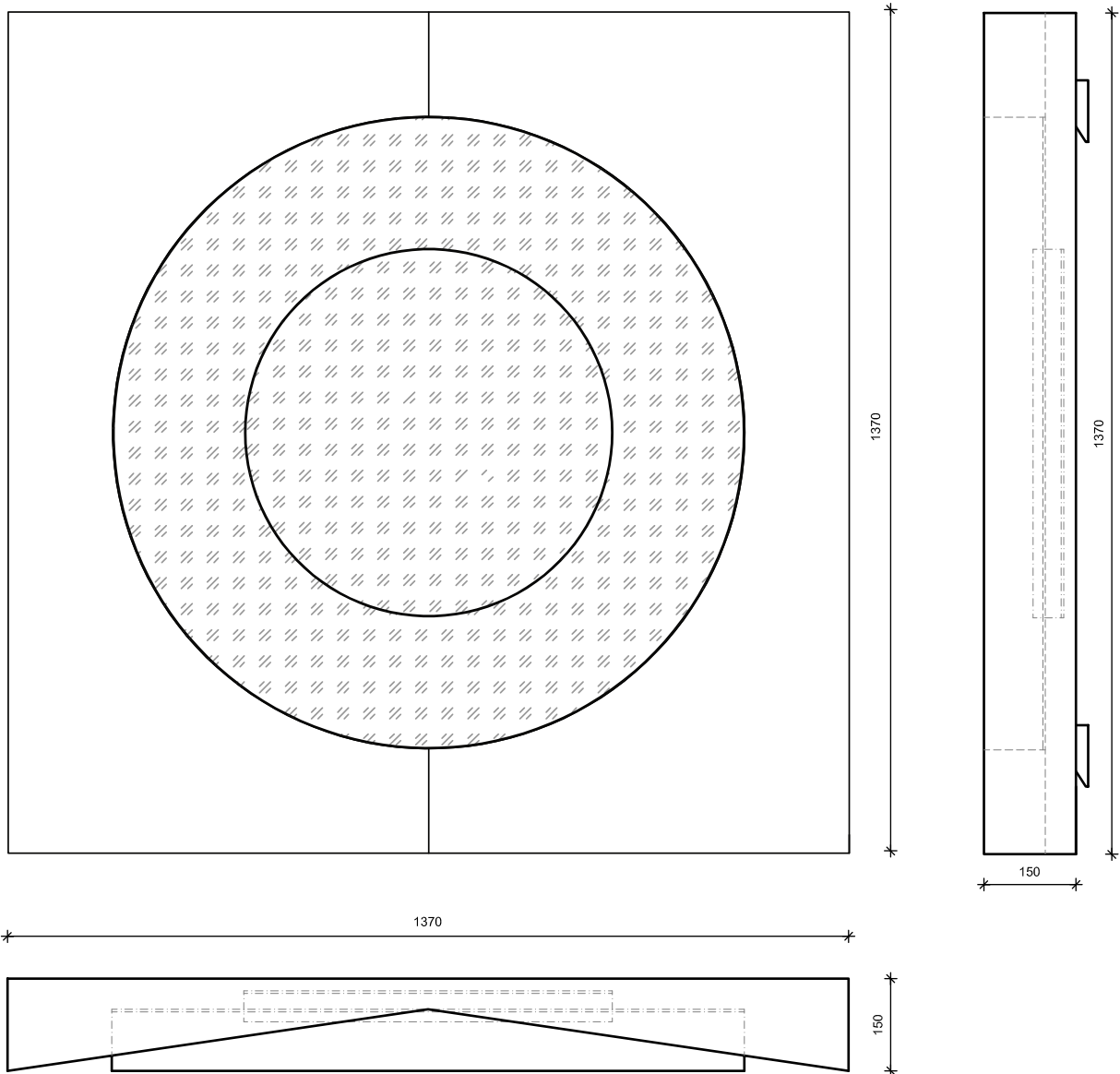
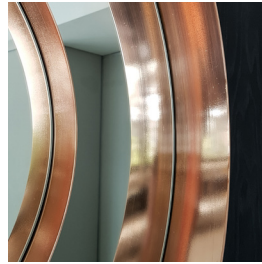

DIMENSIONS

1370W x 150D x 1370H mm

DESCRIPTION

Carbon Stained open grain Ash Timber Base with recessed mirror polished & sealed polished Copper rings.

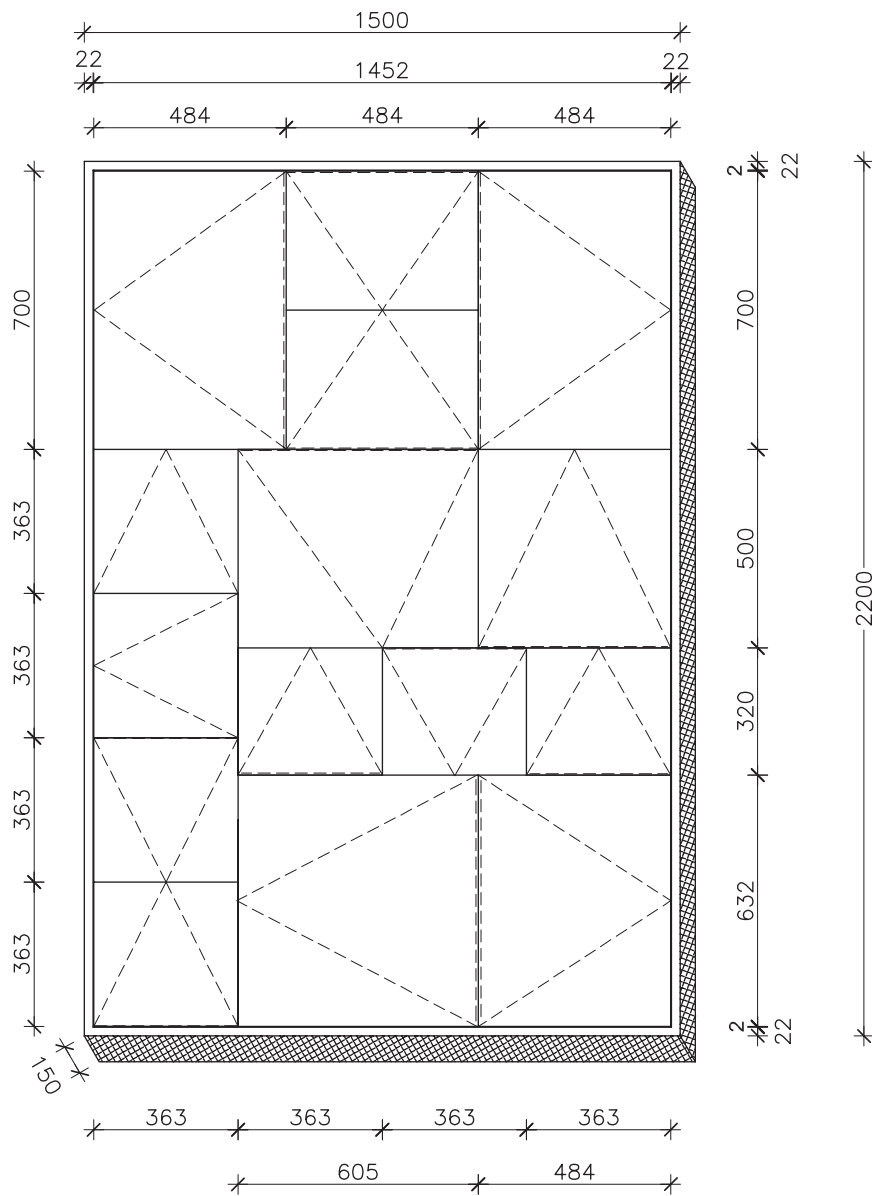

DIMENSIONS

MILD STEEL: 1500W x 150D x 2200H mm

COPPER: 1500W x 150D x 2000H mm

DESCRIPTION

Recessed mirrors set in a mild steel frame or copper clad mild steel frame. Mirrors available in clear, grey or bronze tint.

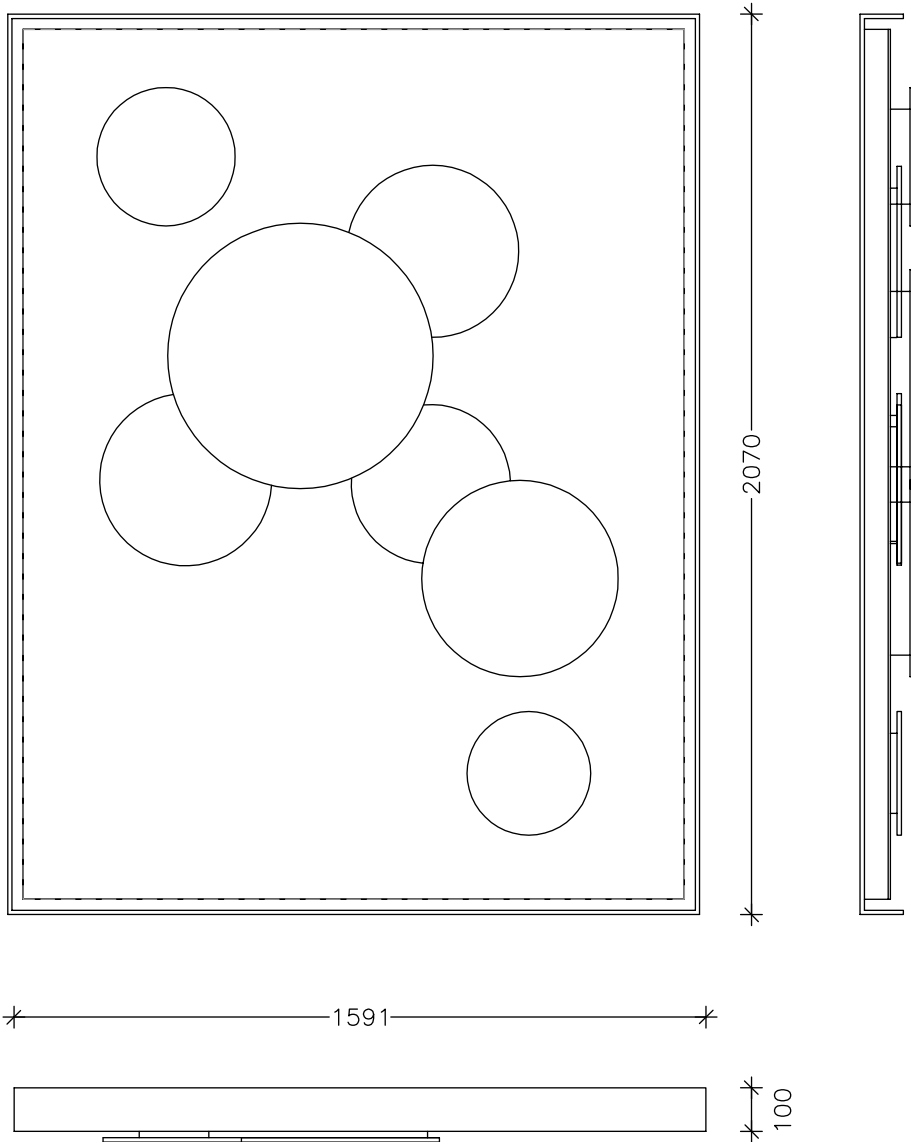

DIMENSIONS

1591W x 100D x 2070H mm

DESCRIPTION

Raw mild steel frame, solid brass cladding and rim lit.
Mirrors available in clear, grey or bronze tint.

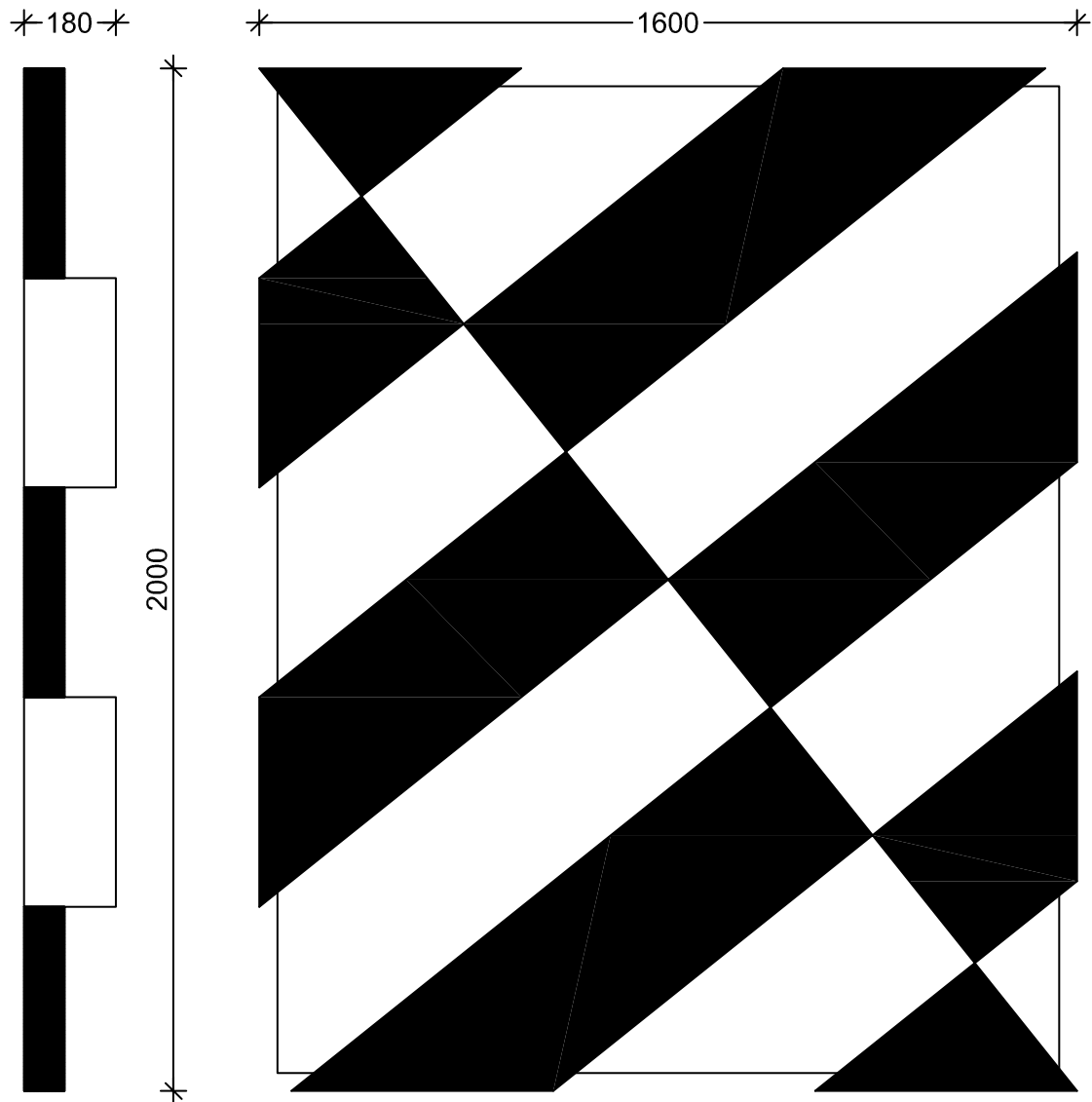

DIMENSIONS

1600W x 180D x 2000H mm

DESCRIPTION

Powder coated steel components combined with mirror elements available in clear, grey or bronze tint. Custom colours available upon request.

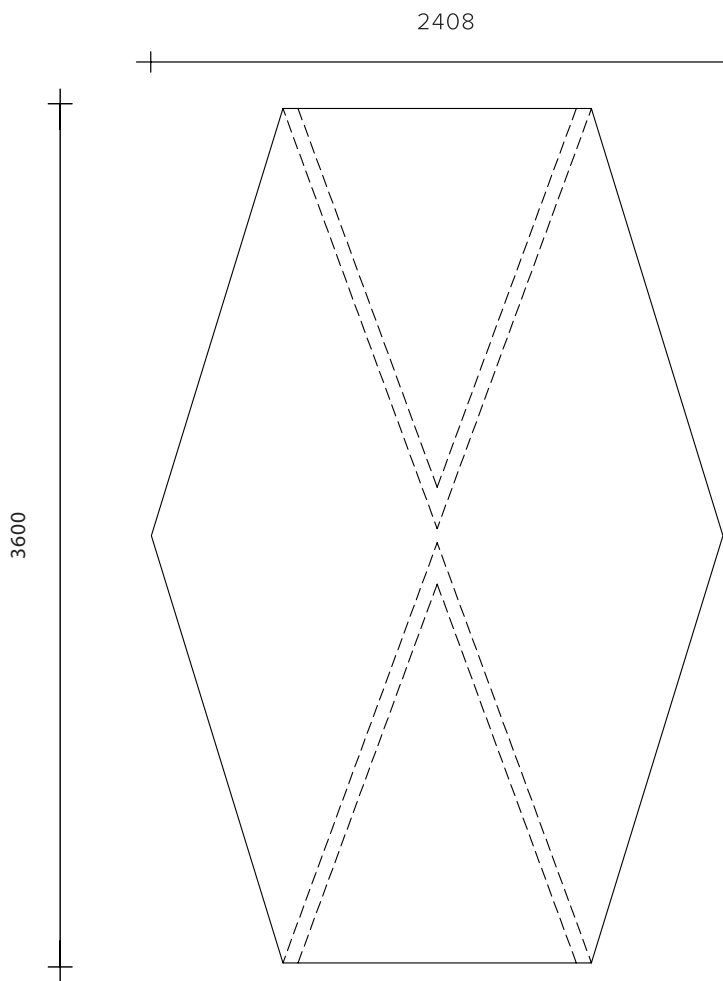

Col. A

DD09	
AA02	
AF07	
CO02	

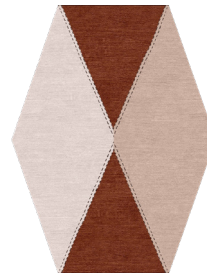

Col. B

AA04	
DP01	
EF12	
AG08	

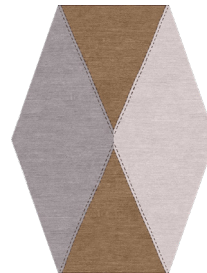

Col. C

AJ11	
AA04	
AJ06	
DT05	

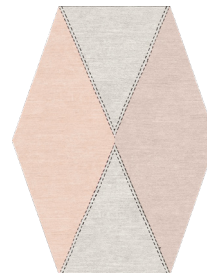

Col. D

AB12	
AA01	
AA12	
DP10	

DIMENSIONS

2408W x 3600D

DESCRIPTION

Hand tufted fine Wool and Bamboo Silk.
Multiple colourways available.

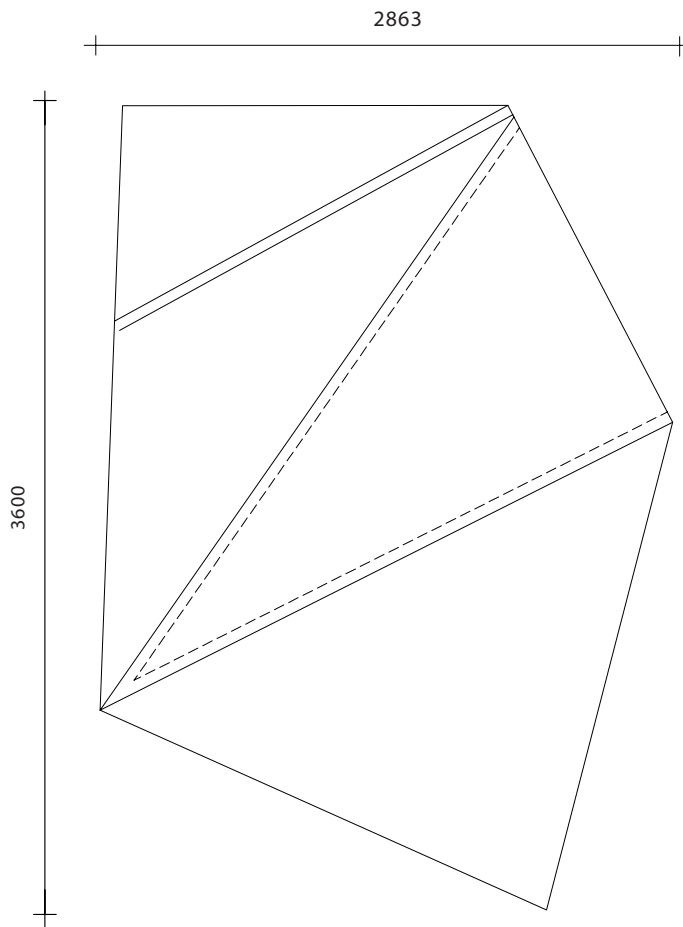

Col. A

CO02	Grey
AA02	Dark Grey
AA10	Dark Grey
AF07	Tan
DD09	Light Tan



Col. B

EF12	Light Grey
AA04	Dark Grey
AG08	Light Grey
DP01	Brown
DT09	Light Tan

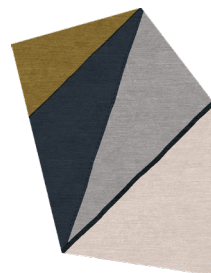

Col. C

AJ11	Light Tan
BL01	Dark Blue
AJ06	Light Grey
BL04	Dark Blue
DT05	Olive Green

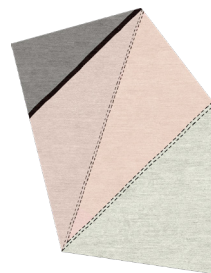

Col. D

AB12	Light Green
AA01	Dark Grey
DP10	Light Tan
AA12	Light Tan
AB05	Dark Brown

DIMENSIONS
2863W x 3600D

DESCRIPTION
Hand tufted fine Wool and Bamboo Silk.
Multiple colourways available.

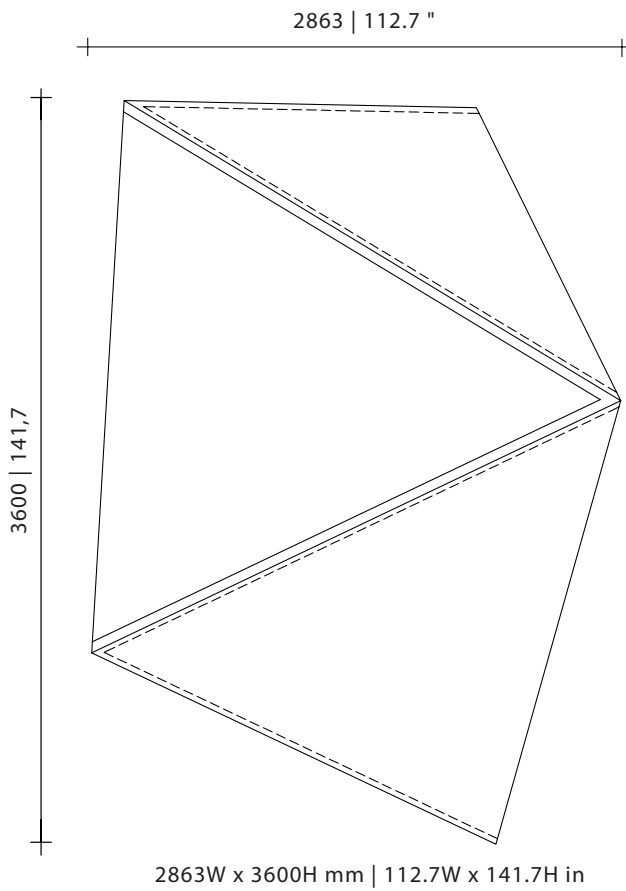
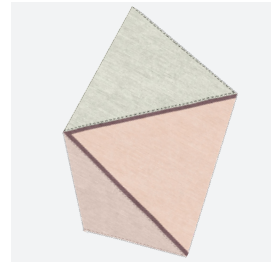

Col. A

AJ11	
BL01	
AJ06	
BL04	
DT05	

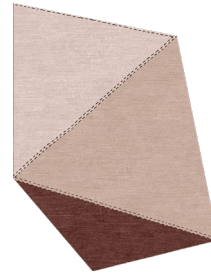

Col. B

EF12	
AA04	
AG08	
DP01	
DT09	

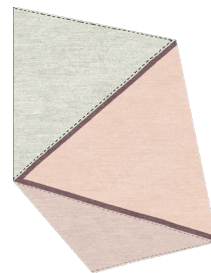

Col. C

AB12	
AA01	
DP10	
AA12	
AB05	

DIMENSIONS

2863W x 3600D

DESCRIPTION

Hand tufted fine Wool and Bamboo Silk.
Multiple colourways available.

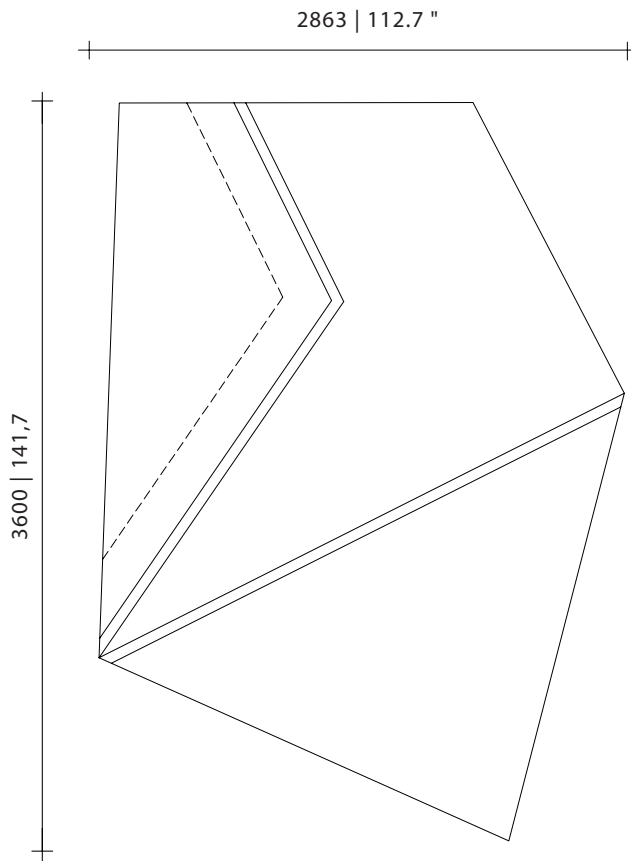

2863W x 3600H mm | 112.7W x 141.7H in



Col. A

AJ11	
BL01	
AJ06	
BL04	
DT05	



Col. B

EF12	
AA04	
AG08	
DP01	
DT09	

DIMENSIONS

2863W x 3600D

DESCRIPTION

Hand tufted fine Wool and Bamboo Silk.
Multiple colourways available.

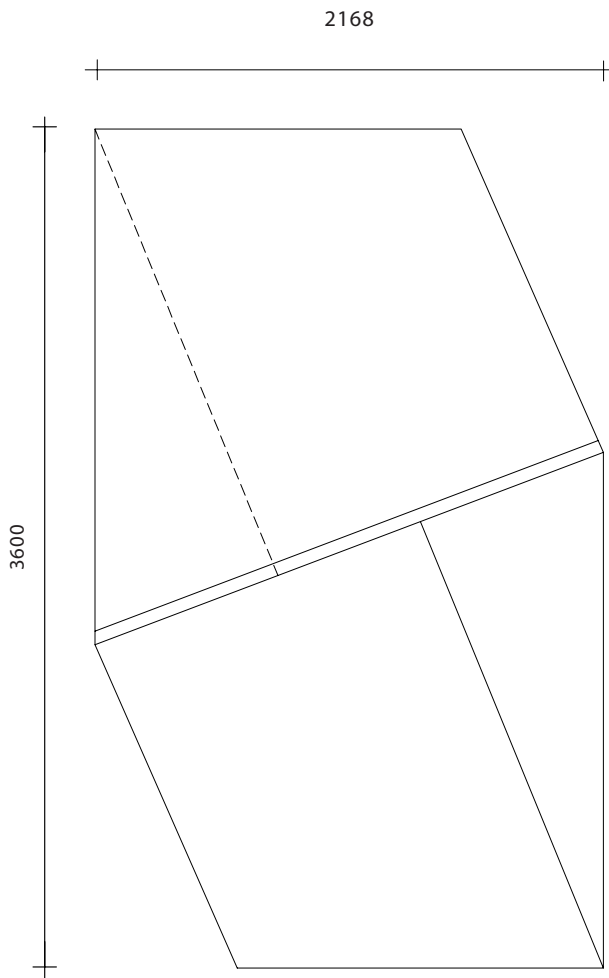
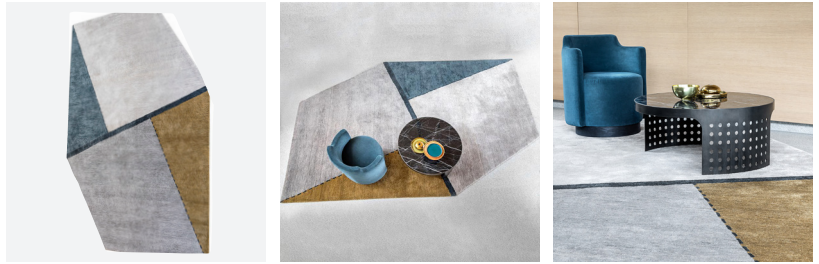

Col. A

AJ11	
BL01	
AJ06	
BL04	
DT05	



Col. B

AA04	
DT09	
DP01	
EF12	
AG08	



Col. C

CO02	
AA04	
AF07	
AA10	
DT09	

DIMENSIONS

2168W x 3600D

DESCRIPTION

Hand tufted fine Wool and Bamboo Silk.
Multiple colourways available.

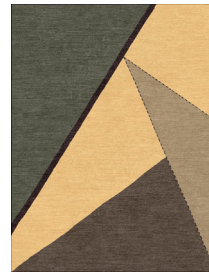
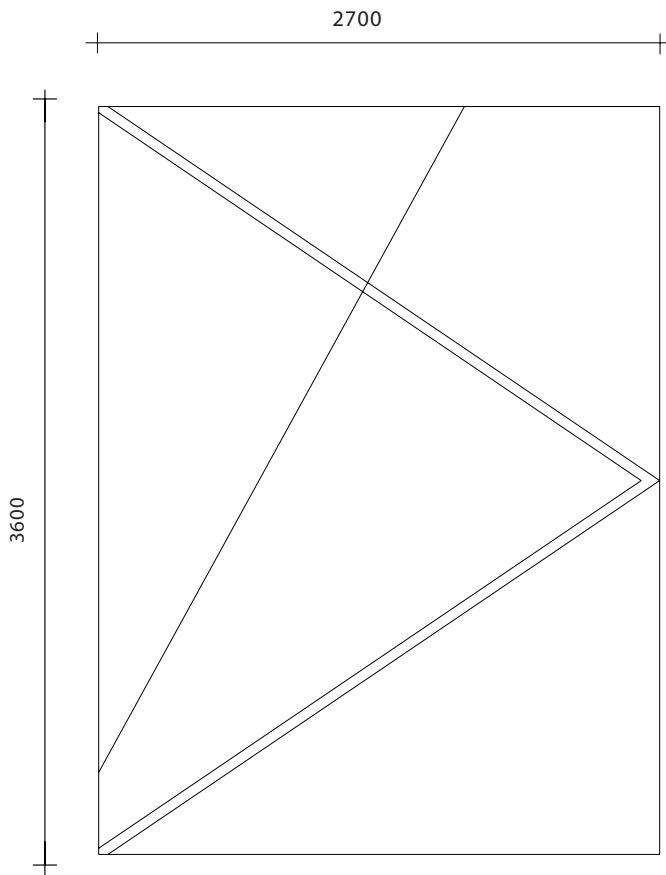
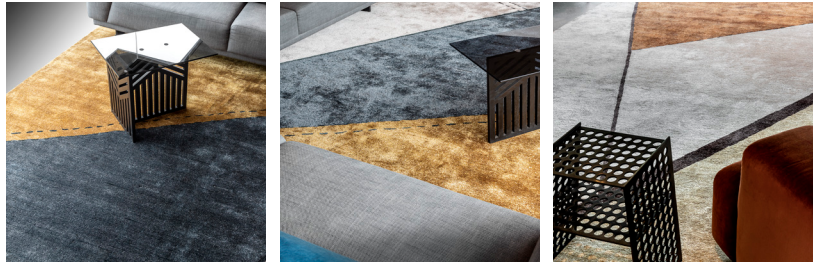

Col. A

AJ11	Light beige
BL01	Dark blue
AJ06	Grey
BL04	Dark blue
DT05	Olive green



Col. B

AA04	Dark blue
DT09	Light beige
DP01	Dark brown
EF12	Light beige
AG08	Light beige

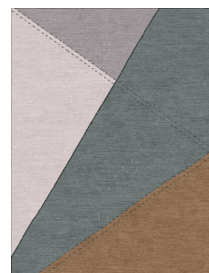

Col. C

CO02	Dark grey
AA04	Dark blue
AF07	Light beige
AA10	Dark brown
DT09	Light beige

DIMENSIONS

2700W x 3600D

DESCRIPTION

Hand tufted fine Wool and Bamboo Silk.
Multiple colourways available.

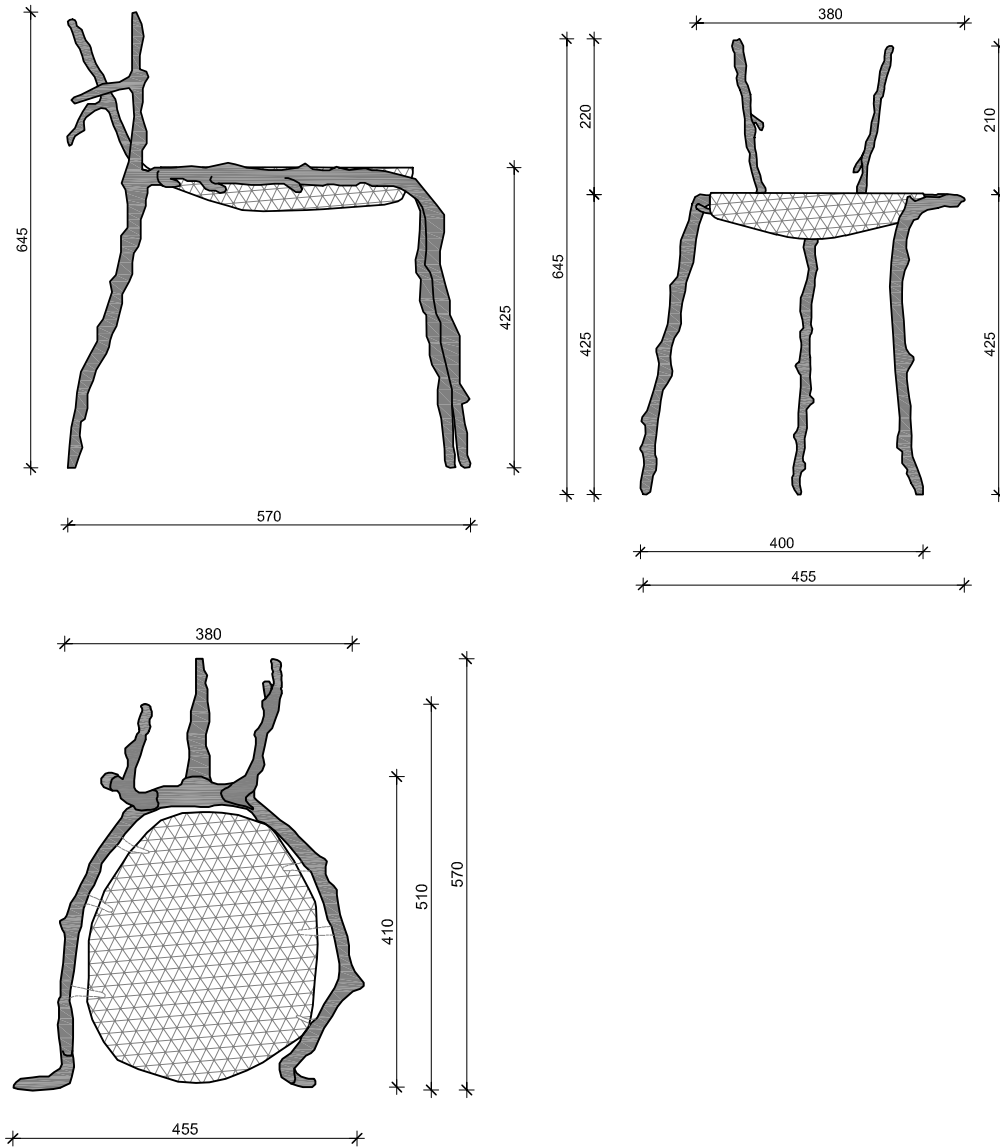

DIMENSIONS

455W x 570D x 645H mm
TABLE TOP HEIGHT: 425 mm

DESCRIPTION

A Limited Edition series consisting of 16 unique hand-made pieces, in collaboration with South African artist and designer, Atang Tshikare.

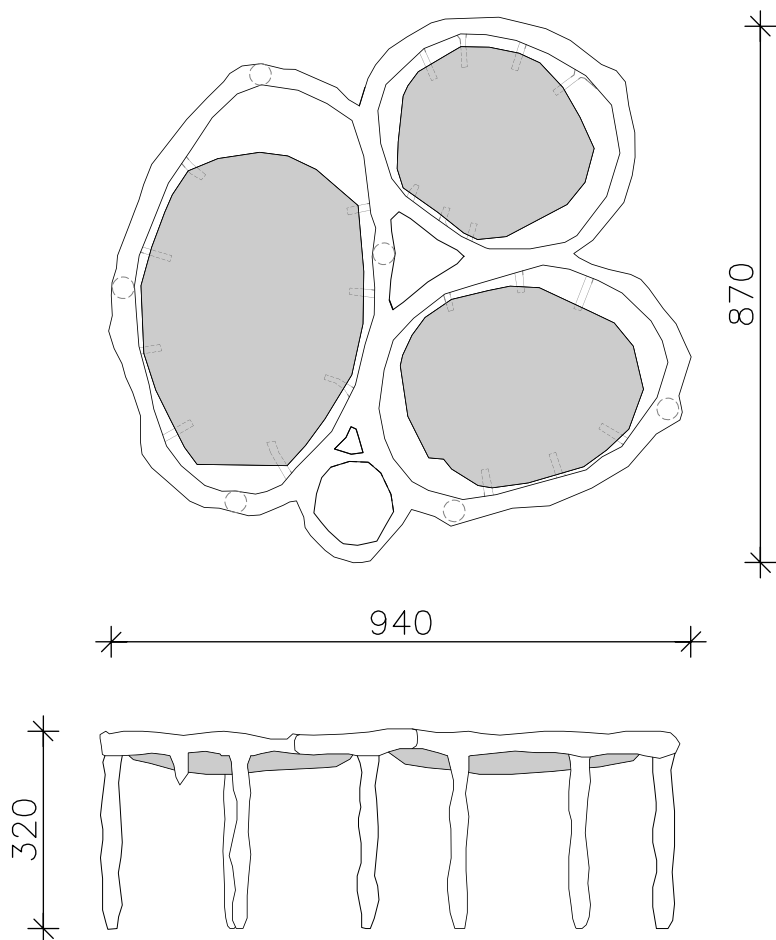

DIMENSIONS

940W x 870D x 320H mm

DESCRIPTION

A Limited Edition series consisting of 16 unique hand-made pieces, in collaboration with South African artist and designer, Atang Tshikare.

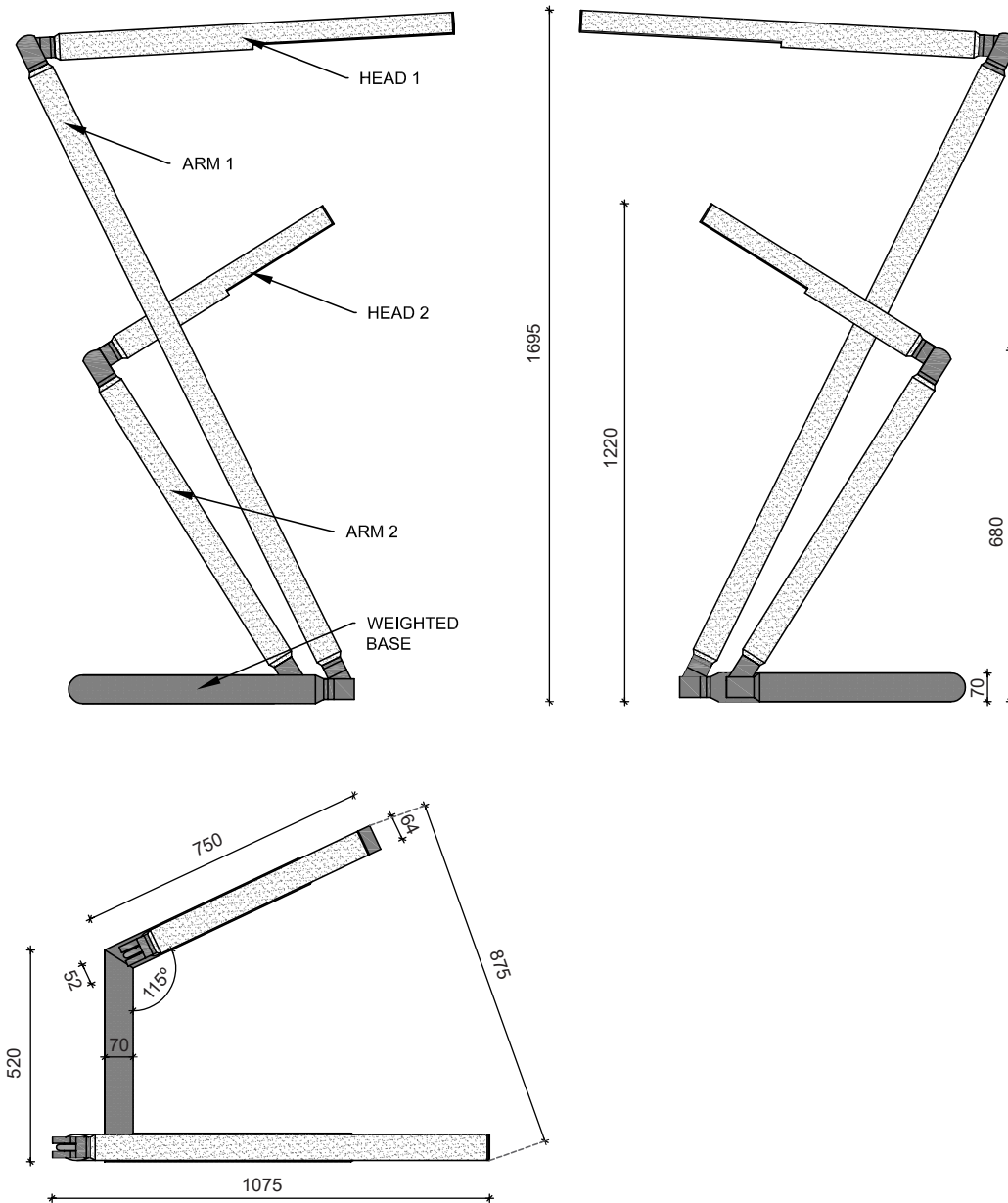

DIMENSIONS

875W x 1075D x 1695H mm

DESCRIPTION

A Limited Edition series consisting of 16 unique hand-made standing lamps, in collaboration with South African artist and designer, Atang Tshikare. Stainless steel frame construction, clad in hand-carved Obeche timber. Nôga is the Setswana word for snake.

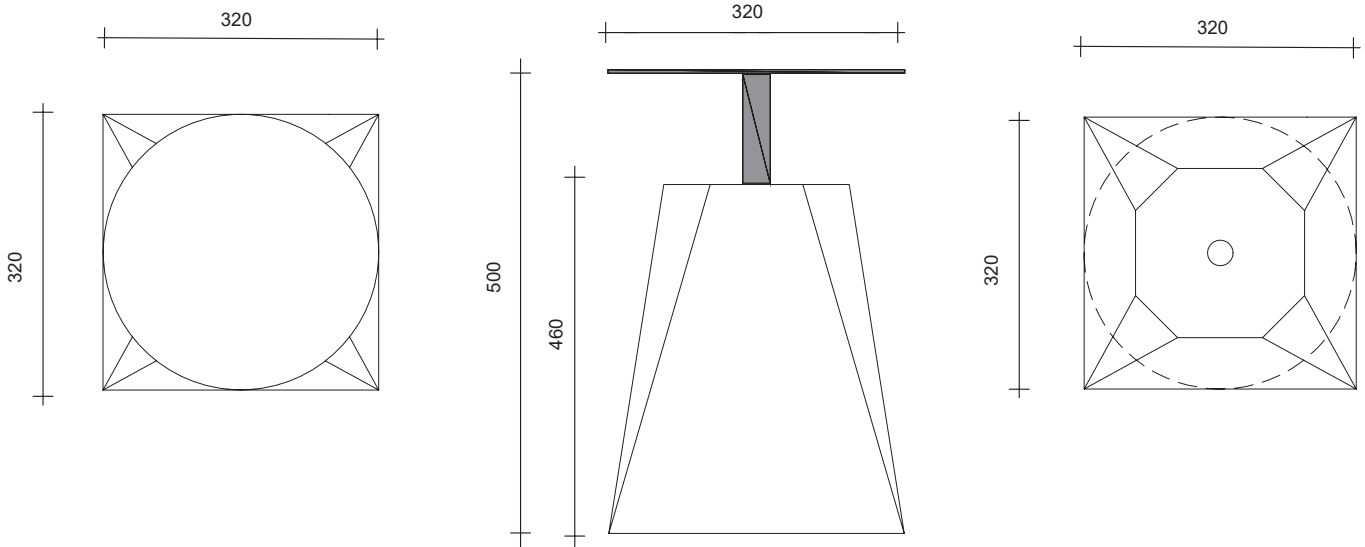

LEATHER OPTIONS | OPTIONAL C.O.M



WOOD OPTIONS



DIMENSIONS
320W x 500H mm

WEIGHT
6kg unboxed

DESCRIPTION
Sculptured timber base, metal disc table surface.

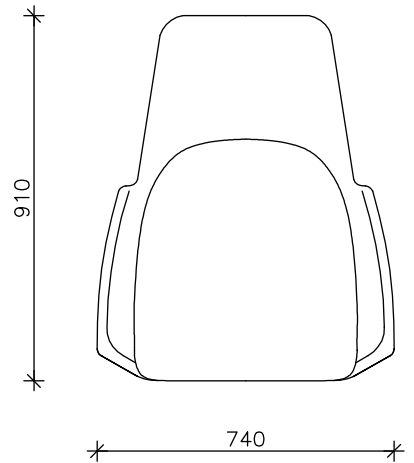
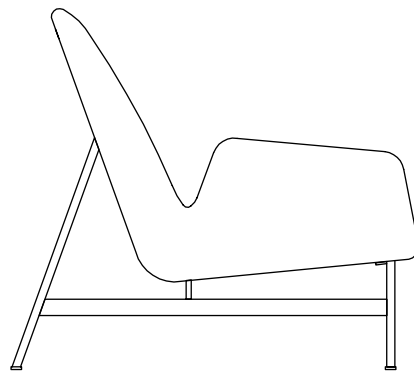
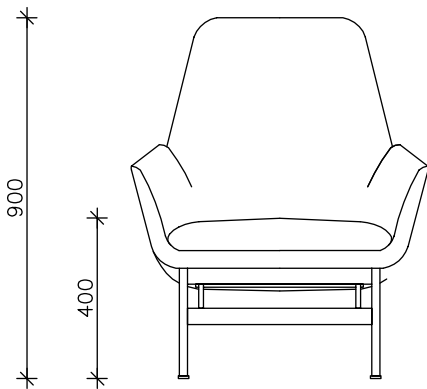

LEATHER OPTIONS | OPTIONAL C.O.M



WOOD OPTIONS



DIMENSIONS

740W x 910D x 900H mm | SEAT HEIGHT 400 mm

DESCRIPTION

Solid wood frame construction, dual density foam cushion.
Black or white powder coated mild steel or polished stainless steel.

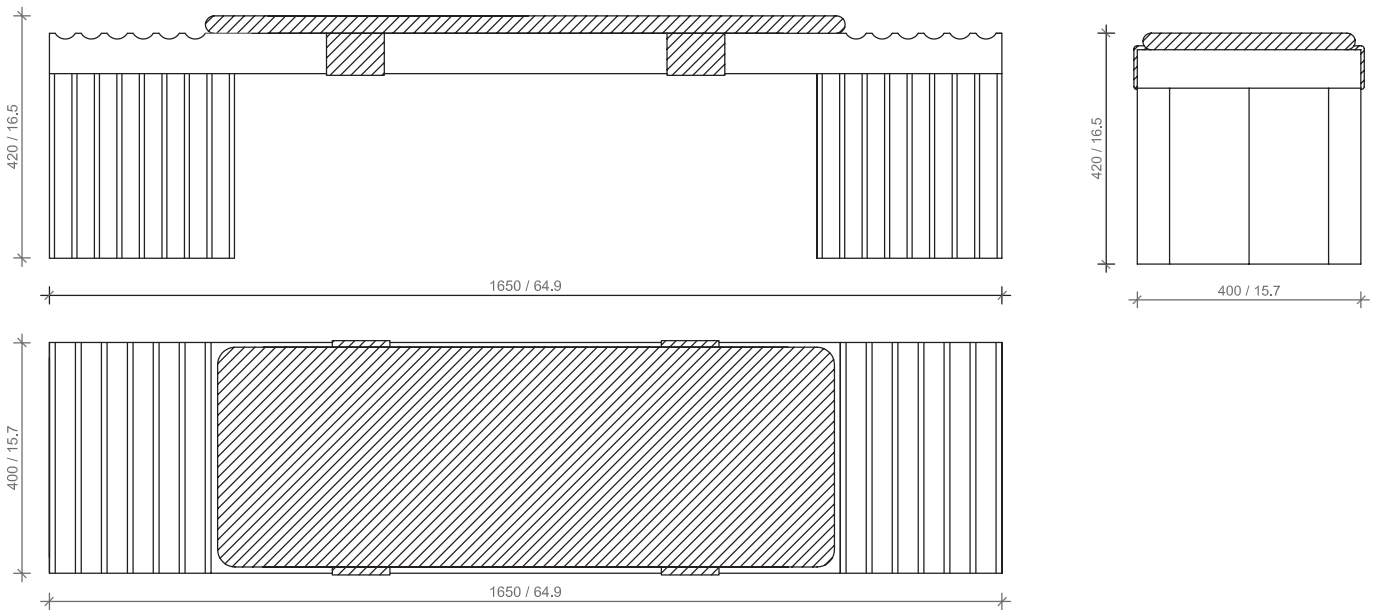

WOOD OPTIONS



DIMENSIONS

1650W x 400D x 420H mm | 64.9W x 15.7D x 16.5H in

DESCRIPTION

Available in all standard solid wood finishes.



Option A

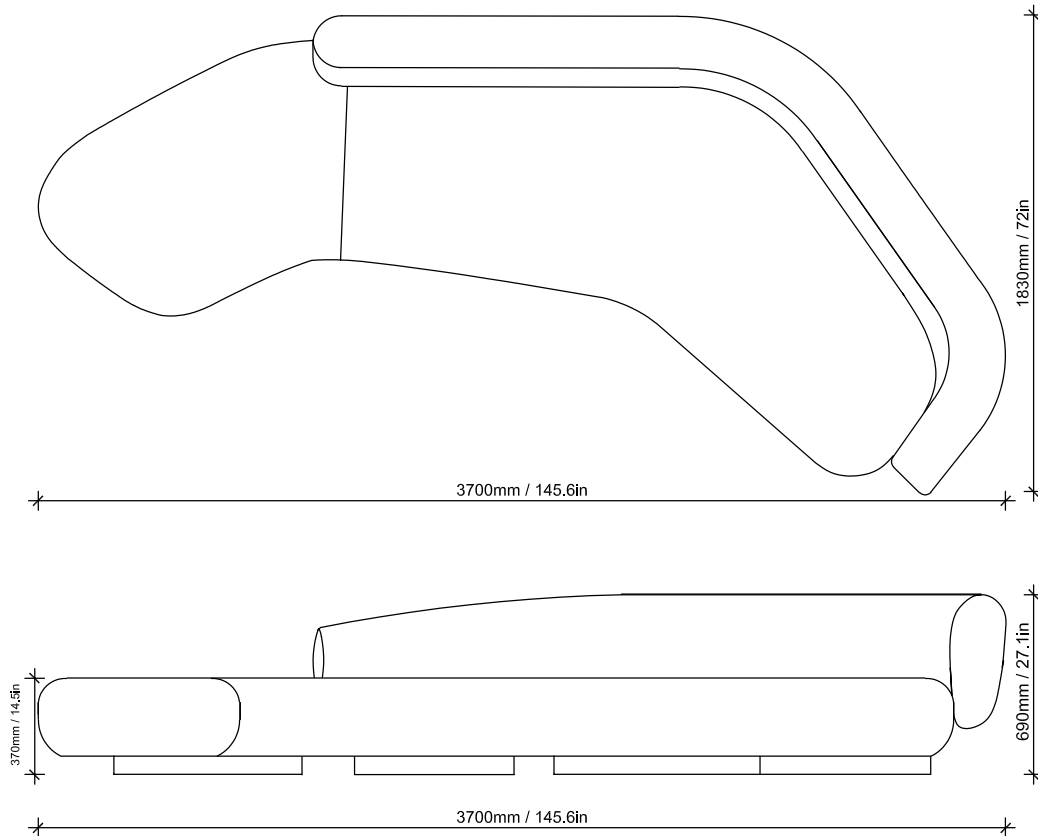

WOOD OPTIONS



DIMENSIONS

3300W x 2430D x 690H mm | SEAT HEIGHT 370 mm | 129.9W x 95.6D x 27.1H in | SEAT HEIGHT 14.5 in

DESCRIPTION

Solid timber frame construction, foam laminate seat and back, timber & antiqued brass base.

Option B

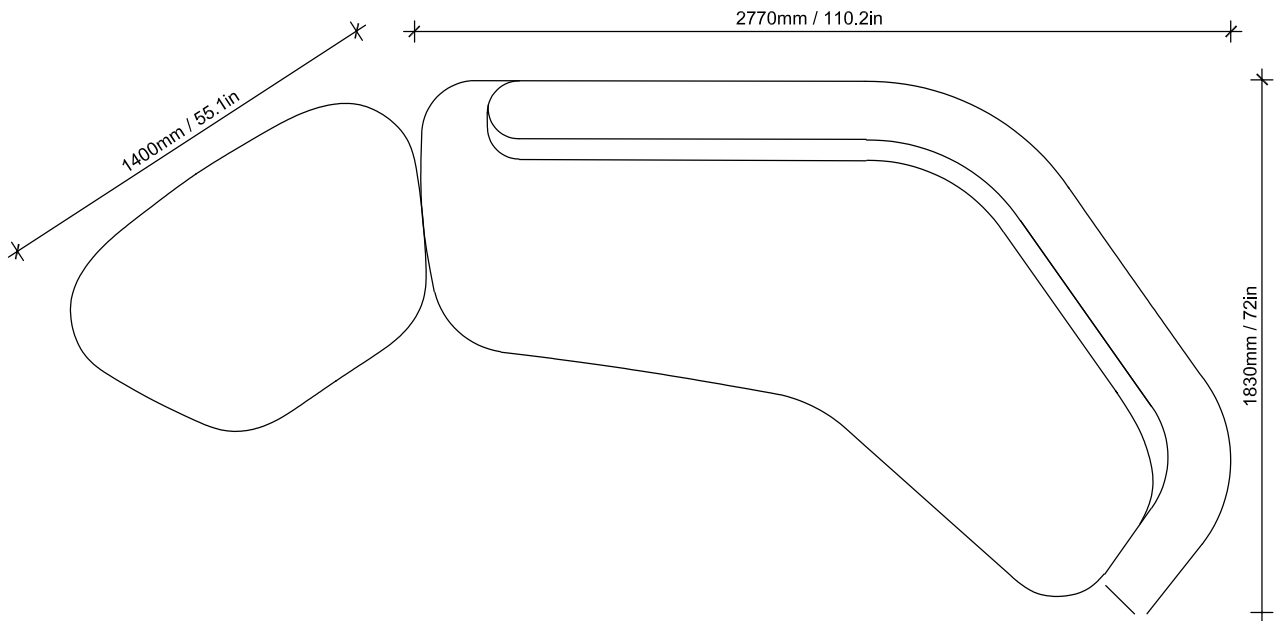

WOOD OPTIONS



Natural Oak

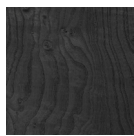

Carbon Oak



Chalked Oak

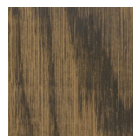

Dark Java Oak



Natural Ash

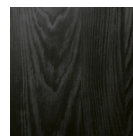

Carbon Ash



Walnut

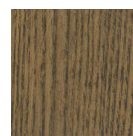

Dark Java Oak

DIMENSIONS

3970W x 1830D x 690H mm | SEAT HEIGHT 370 mm | 1872W x 874D x 27.1H in | SEAT HEIGHT 14.5 in

DESCRIPTION

Solid timber frame construction, foam laminate seat and back, timber & antiqued brass base.

Option C

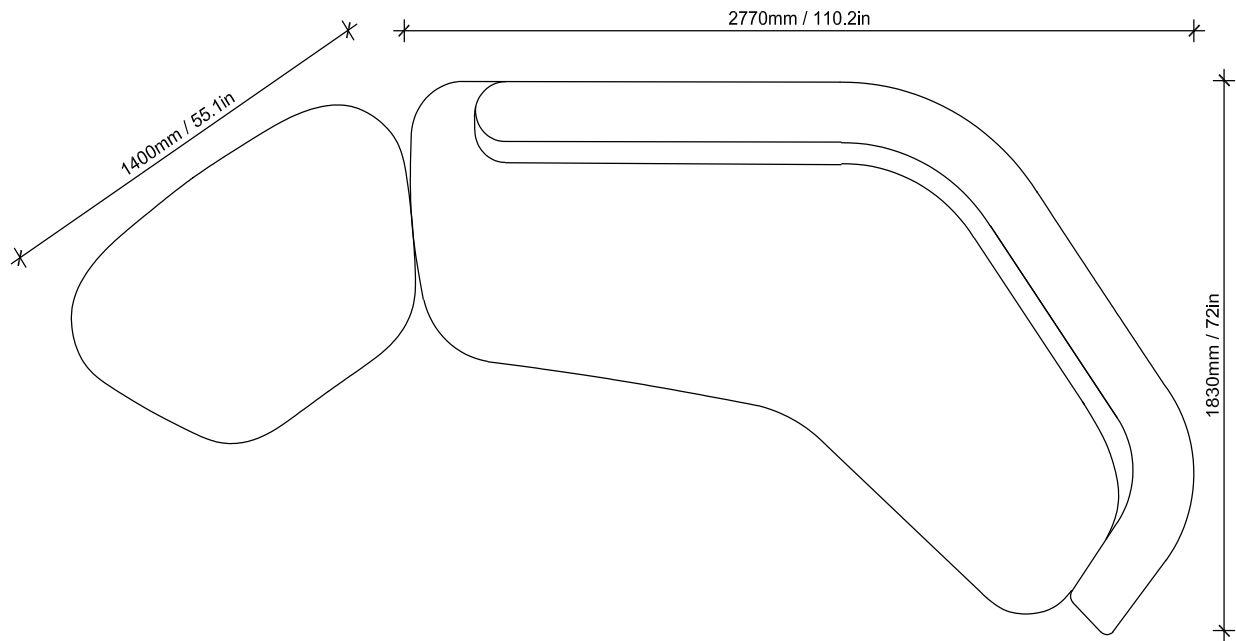

WOOD OPTIONS



Natural Oak



Carbon Oak



Chalked Oak

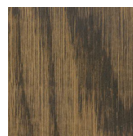

Dark Java Ash



Natural Ash



Carbon Ash



Walnut



Dark Java Oak

DIMENSIONS

3300W x 2430D x 690H mm | SEAT HEIGHT 370 mm | 129.9W x 95.6D x 27.1H in | SEAT HEIGHT 14.5 in

DESCRIPTION

Solid timber frame construction, foam laminate seat and back, timber & antiqued brass base.

Option D

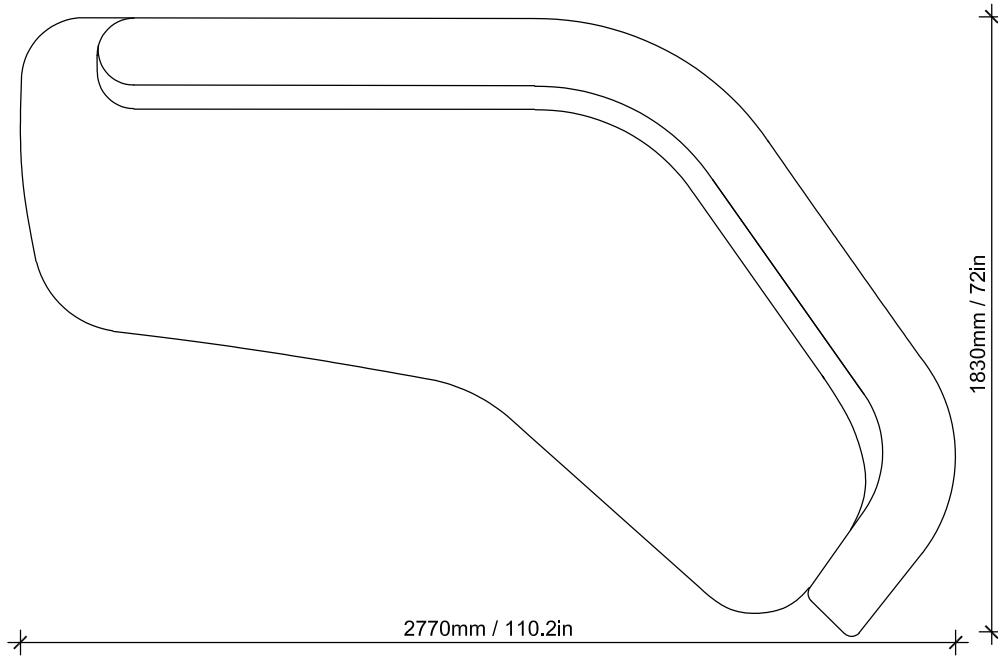

WOOD OPTIONS



Natural Oak



Carbon Oak



Chalked Oak

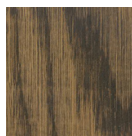

Dark Java Ash



Natural Ash



Carbon Ash

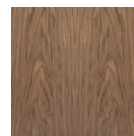

Walnut

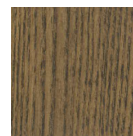

Dark Java Oak

DIMENSIONS

3300W x 2430D x 690H mm | SEAT HEIGHT 370 mm | 129.9W x 95.6D x 27.1H in | SEAT HEIGHT 14.5 in

DESCRIPTION

Solid timber frame construction, foam laminate seat and back, timber & antiqued brass base.

Option E

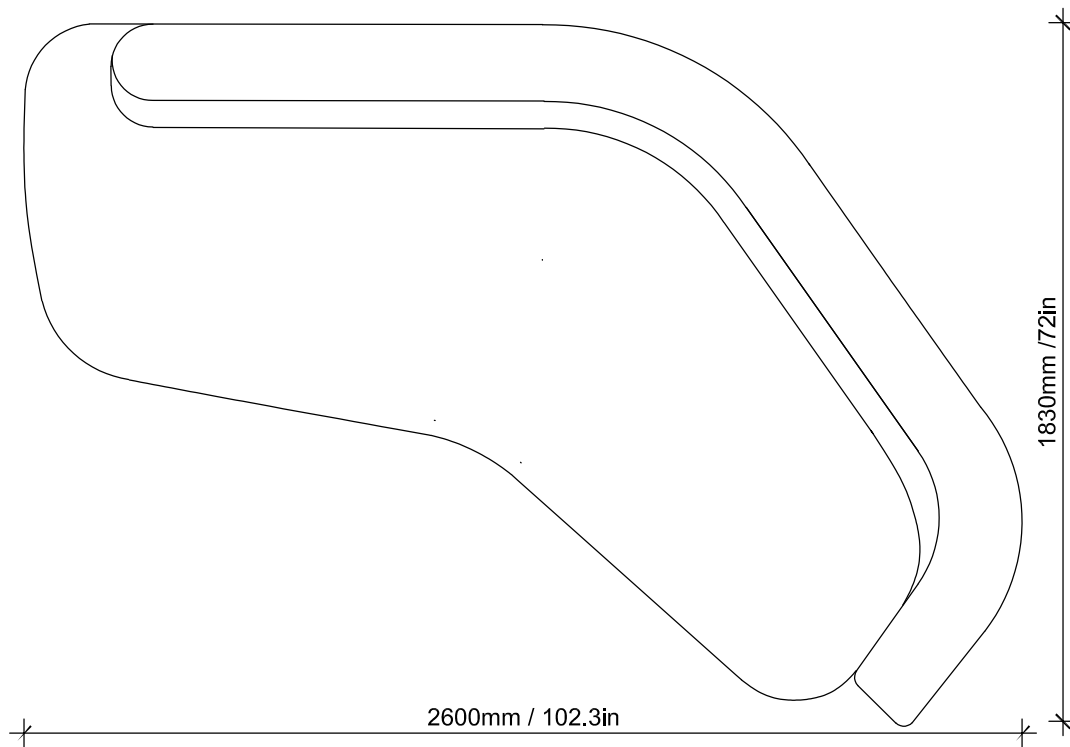

WOOD OPTIONS



DIMENSIONS

2600W x 1830D x 690H mm | SEAT HEIGHT 370 mm | 1224W x 864D x 27.1H in | SEAT HEIGHT 14.5 in

DESCRIPTION

Solid timber frame construction, foam laminate seat and back, timber & antiqued brass base.

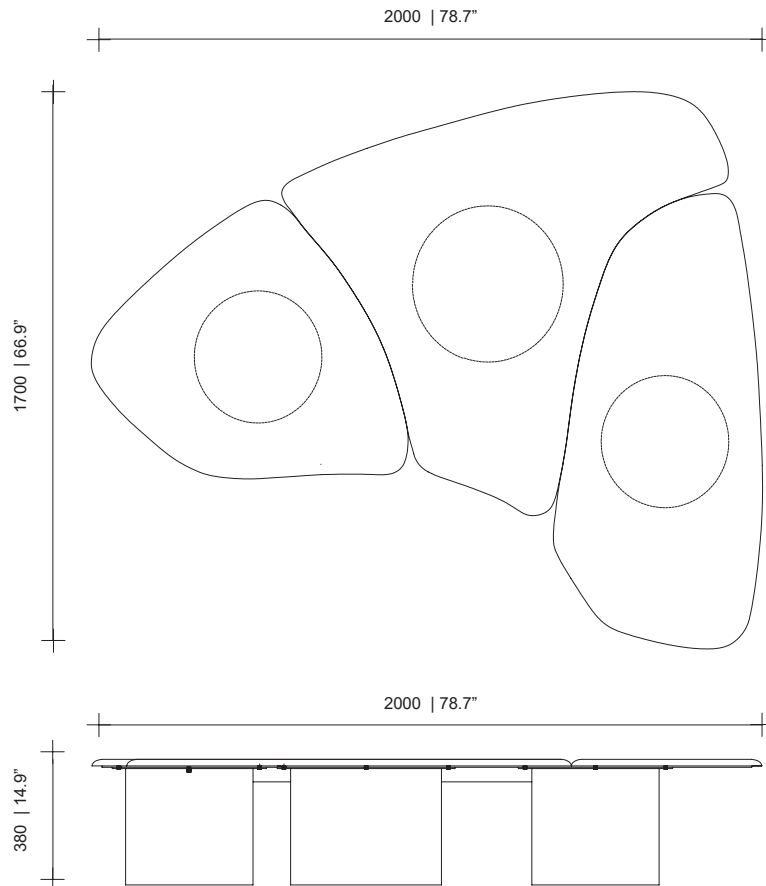

METAL OPTIONS

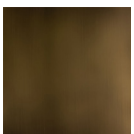

Oxidised Brass

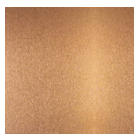

Brushed Copper

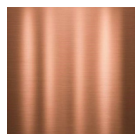

Polished Copper

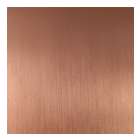

Satin Copper

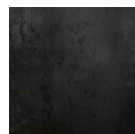

Mild Steel



Polished Stainless Steel

DIMENSIONS

2000W x 1700D x 380H mm | 78.7W x 66.9D x 14.9H in

DESCRIPTION

Hot rolled blue black waxed mild steel base. Custom choice of stone tops.

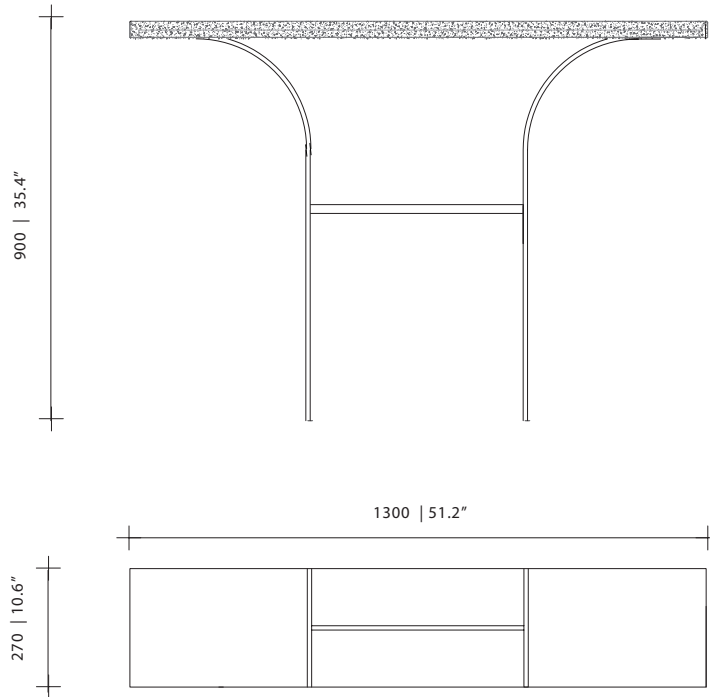

METAL OPTIONS



DIMENSIONS

1300W x 270D x 900H mm | 51.2W x 10.6D x 35.4H in

DESCRIPTION

Hot rolled blue black waxed mild steel base. Custom choice of stone tops. Brass or copper rod detail.

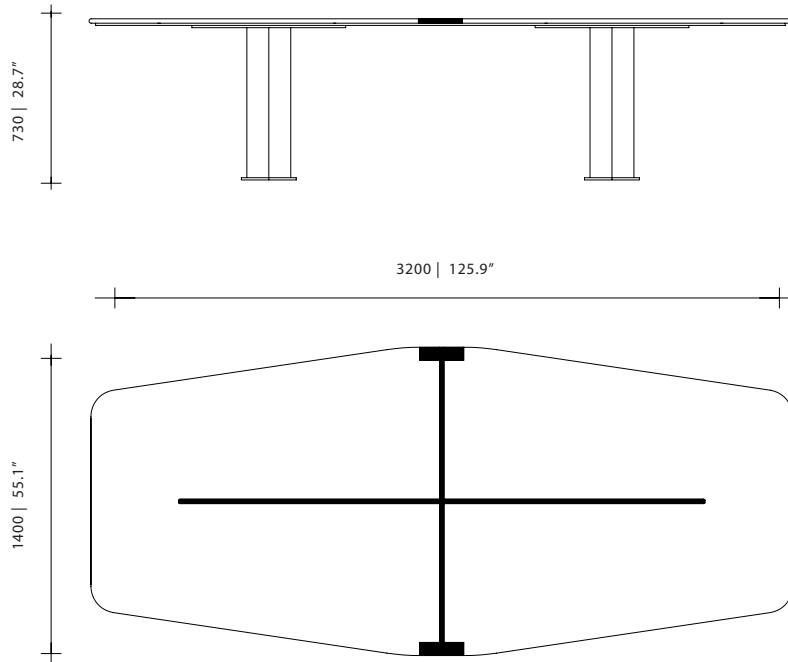

METAL OPTIONS

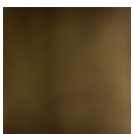

Oxidised Brass

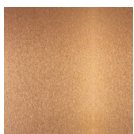

Brushed Copper

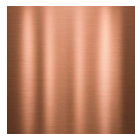

Polished Copper

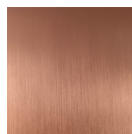

Satin Copper



White
Ferrograin

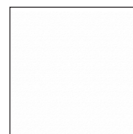

White Satin



Black High Gloss

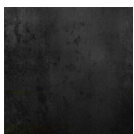

Mild Steel

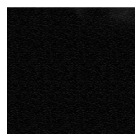

Black Ferrograin



Saddle Wood
Ferrograin



Light Grey
High Gloss

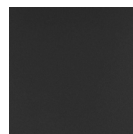

Charcoal Satin



Light Grey
Ferrograin

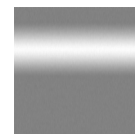

Polished Stainless
Steel

DIMENSIONS

3200W x 1400D x 730H mm | 125.9W x 55.1D x 28.7H in

DESCRIPTION

Hot rolled blue black waxed mild steel base. Custom choice of stone tops
Brass table insert detail

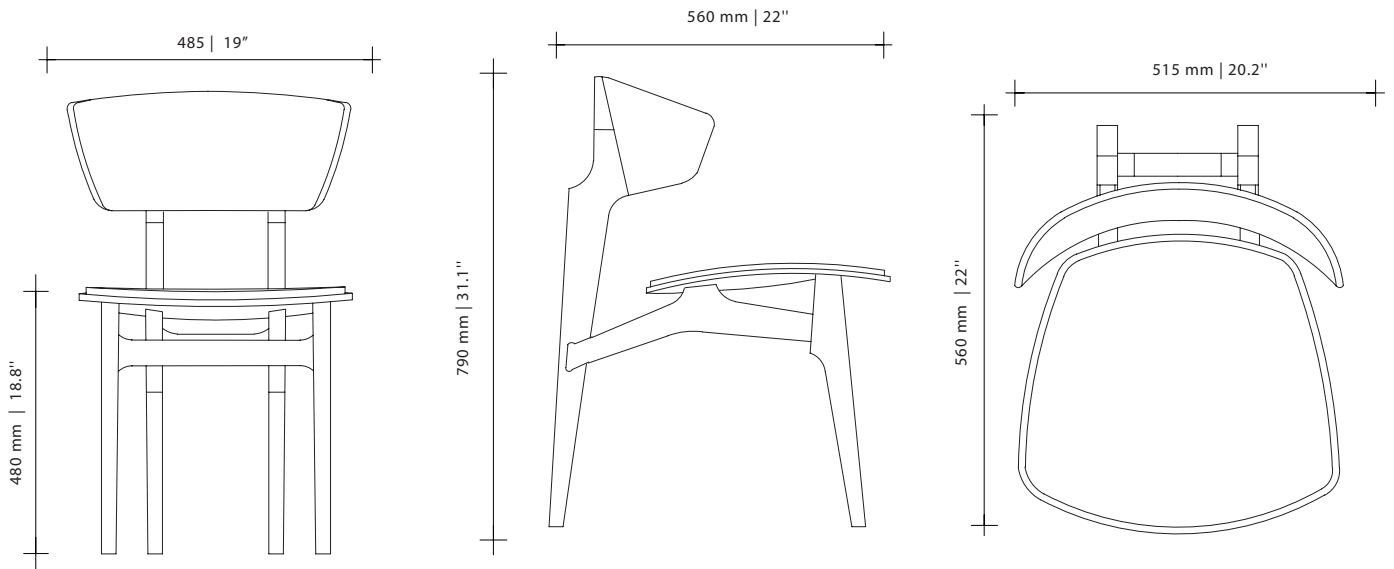

LEATHER OPTIONS | OPTIONAL C.O.M



WOOD OPTIONS



DIMENSIONS

485W x 560D x 790H mm | 19W x 22D x 31.1H in
SEAT HEIGHT 480 mm | 18.8 in

DESCRIPTION

Available in all std solid wood finishes.