

SOFA SYSTEM

PERRY

DESIGN ANTONIO CITTERIO

SOFA SYSTEM

PERRY

DESIGN ANTONIO CITTERIO

FLEXFORM

“WITH THIS CONCEPT, I WANTED TO EXEMPLIFY A FURNISHING IDEA THAT, THROUGH UNEXPECTED SHAPES, EXPRESSES VIBRANT MINIMALISM.”

Antonio Citterio

Pensato per progettare gli spazi living in modo non convenzionale, Perry è il sistema di sedute disegnato da Antonio Citterio con l'obiettivo di coniugare essenzialità ed eleganza, originalità formale e cura del dettaglio. La varietà degli elementi di seduta, aggregabili tra loro con grande flessibilità, permette di dare forma a inusuali configurazioni dal carattere dinamico. I moduli, imbottiti in piuma d'oca, presentano dimensioni generose, proporzioni calibrate e dettagli minuziosamente studiati; il profilo in gros-grain, che disegna la silhouette degli elementi, definisce elegantemente il volume del divano, mentre la libera disposizione di cuscini in appoggio allo schienale contribuisce a sottolineare l'immagine informale del prodotto. Un sistema che rappresenta una nuova soluzione espressiva e progettuale e che, grazie alla libera combinazione con gli altri arredi della collezione, dai tavolini alle poltrone, dai pouf alle chaise longue, conferisce unicità e ricercatezza all'ambiente living.

Designed to furnish living spaces in an unconventional manner, Perry is the seating system designed by Antonio Citterio with the aim of combining simplicity and elegance, formal originality and attention to detail. The variety of seating elements that can be clustered among themselves with great flexibility, allows the creation of unusual configurations with dynamic personalities. The modules are padded with goose down, have generous dimensions, calibrated proportions and meticulously studied details – the grosgrain piping that outlines the silhouette of the upholstered elements elegantly defines the shape of the sofa, while the free arrangement of cushions placed against the backrest highlights the informal nature of the product. A seating system that symbolizes a new expressive design solution and that can be combined at will with the other furnishings in the collection – from coffee tables to armchairs and ottomans to chaise longues – lends uniqueness and sophistication to any living space.

A NEW DOMESTIC LANDSCAPE,
INFORMAL, DYNAMIC AND ORIGINAL,
TAKES SHAPE.

LA PERSONALITÀ DI PERRY SI ESPRIME PIENAMENTE NELLA CONFIGURAZIONE VIS-A-VIS CON MODULI
DALE FORME ATIPICHE, CHE, COME INSOLITE ISOLE CONFORTEVOLI, DISEGNANO LO SPAZIO.

PERRY'S PERSONALITY IS FULLY CONVEYED IN THE CONFIGURATION WITH ASYMMETRIC MODULES
PLACED FACING EACH OTHER THAT, LIKE EXOTIC COMFORTABLE ISLANDS, DESIGN THE SPACE.







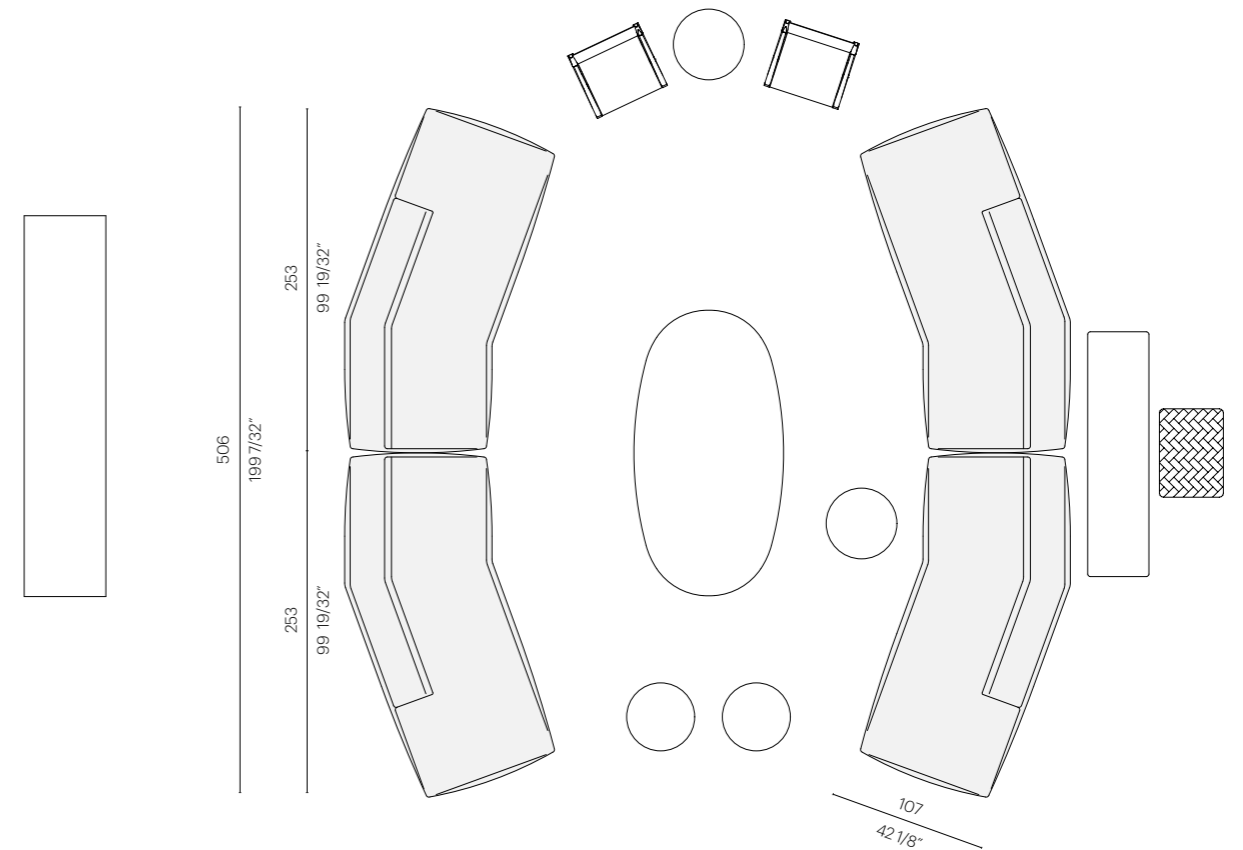

Perry, divano componibile base in alluminio color antracite lucido, cuscini di seduta e schienale rivestiti in tessuto Manila 750, profilo in gros grain 10400, cuscini optional rivestiti in tessuto Tao 1790. **Luchino, sedie pieghevoli** seduta e schienale in cuoio color tabacco 5015, struttura in noce canaletto effetto grezzo e metallo titanium opaco 710. **Arnold, tavolino** struttura in noce canaletto effetto grezzo, piedi in metallo titanium opaco 710, piano in noce canaletto effetto grezzo. **Feel good, pouf** seduta e cucino rivestiti in tessuto Everyday 880, piedi in metallo titanium opaco 710. **Earl, contenitore** struttura impiallacciata in noce canaletto effetto grezzo, piano in marmo Calacatta oro opaco, piedi in metallo titanium opaco 710. **Zefiro, tavolini** struttura in metallo titanium opaco 710, piano in noce canaletto effetto grezzo. **Fly, consolle** struttura in metallo titanium opaco 710, piano in marmo Calacatta oro opaco. **Filicudi, pouf** seduta rivestita in cuoio intrecciato color tabacco 5015, piedi in metallo titanium opaco 710, Design Center design. **Inca, tappeto** lana e cotone, colore Stone, Juma design.

Perry, sectional sofa base in aluminum, glossy anthracite color, seat and backrest cushions upholstered in Manila 750 fabric, grosgrain 10400 piping, optional cushions upholstered in Tao 1790 fabric. **Luchino, folding chairs** seat and backrest in cowhide color tobacco 5015, Canaletto walnut structure with raw-wood effect and metal in matt titanium 710. **Arnold, coffee table** structure in Canaletto walnut with raw-wood effect, metal feet in matt titanium 710, top in Canaletto walnut with raw-wood effect. **Feel good, ottomans** seat and cushion upholstered in Everyday 880 fabric, metal feet in matt titanium 710. **Earl, storage unit** structure veneered in Canaletto walnut with raw-wood effect, top in matt Calacatta Gold marble, metal feet in matt titanium 710. **Zefiro, side tables** metal structure in matt titanium 710, top in Canaletto walnut with raw-wood effect. **Fly, console table** metal structure in matt titanium 710, top in matt Calacatta Gold marble. **Filicudi, ottoman** seat upholstered in woven cowhide color tobacco 5015, metal feet in matt titanium 710, Design Center design. **Inca, rug** wool and cotton, Stone color, Juma design.

BETWEEN HARMONIOUS PROPORTIONS
AND SOPHISTICATED DETAILS, EVEN IN ITS
MORE TRADITIONAL CONFIGURATION,
THE SOFA EMERGES RE-IMAGINED.

LE VERSIONI LINEARI, PREVISTE NEL PROGETTO IN PIÙ DIMENSIONI, SI DIMOSTRANO IDEALI PER COLLOCAZIONI CONTRAPPOSTE CHE INVITANO A UNA NUOVA CONVIVIALITÀ, SOBRIA E RILASSATA.

THE STAND-ALONE VERSIONS, AVAILABLE IN SEVERAL SIZES, WHEN PLACED FACE-TO-FACE ARE AN INVITATION TO A NEW BRAND OF UNDERSTATED, RELAXED HOSPITALITY.





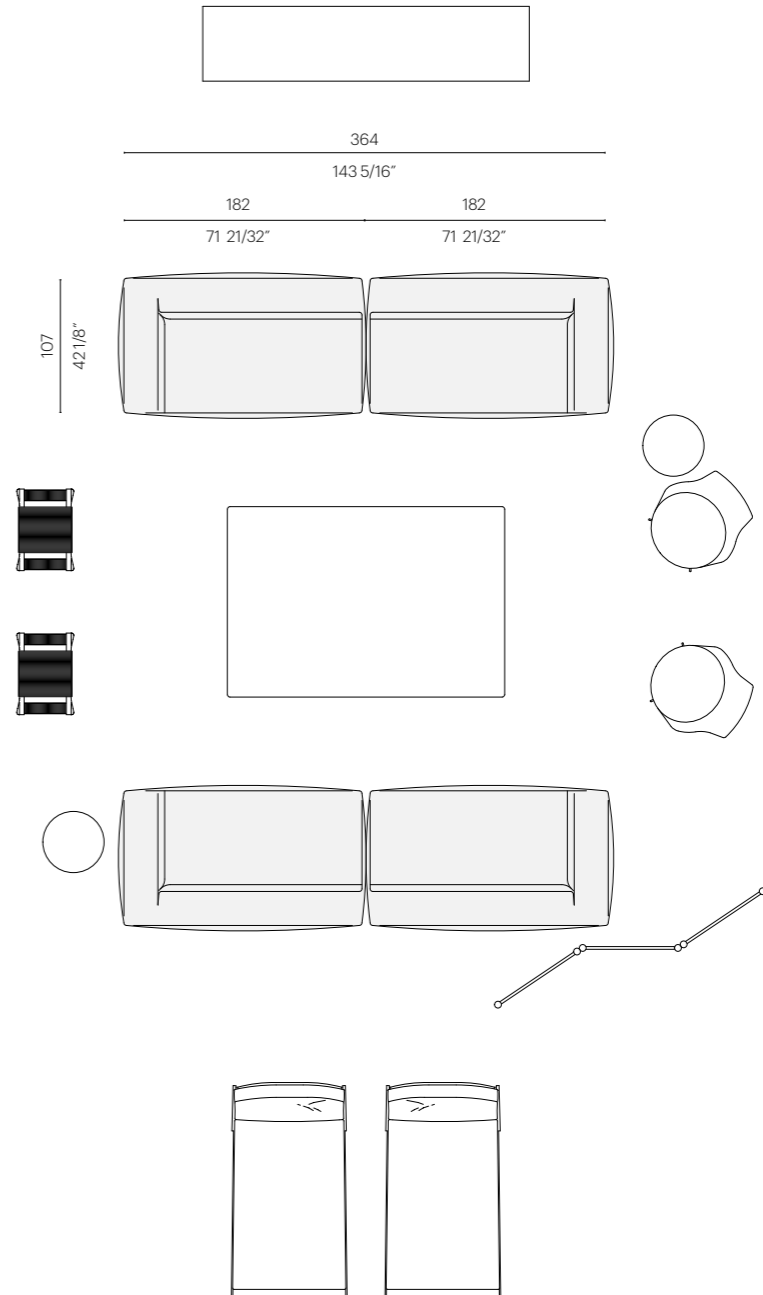

Perry, divano componibile base in alluminio color antracite lucido, cuscini di seduta e schienale rivestiti in tessuto Medina 93, profilo in gros grain 051, cuscini optional rivestiti in tessuto Egypt 97. **Fly, tavolino** struttura in metallo titanium opaco 710, piano in marmo Calacatta oro opaco. **Guscio, poltrone** schienale e cuscino rivestiti in Nabuk Deluxe 702, piedi in metallo titanium opaco 710. **Giano, pouf** struttura in rovere effetto grezzo, seduta in cuoio intrecciato color oliva 5006. **Parker, paravento** struttura in rovere effetto grezzo, cinghie in cuoio color nero, intreccio in paglia di fiume. **Adler, tavolini** struttura in rovere effetto grezzo, piedi in metallo titanium opaco 710, piano in rovere effetto grezzo. **Piuma, contenitore** struttura impiallacciata in rovere effetto grezzo, piedi in metallo titanium opaco 710. **Happy, chaise longue** cuscini di seduta e schienale rivestiti in tessuto Elettra 201, schienale in cuoio intrecciato color oliva 5006, struttura in metallo rivestito in cuoio color oliva 5006, piedi in metallo titanium opaco 710.

Mori, tappeto lana e cotone, colore Milk, Juma design.

Perry, sectional sofa base in aluminum, glossy anthracite color, seat and backrest cushions upholstered in Medina 93 fabric, grosgrain 051 piping, optional cushions upholstered in Egypt 97 fabric. **Fly, coffee table** metal structure in matt titanium 710, top in matt Calacatta Gold marble. **Guscio, armchairs** backrest and cushion upholstered in Nubuck Deluxe 702, metal feet in matt titanium 710. **Giano, ottomans** structure in oak with raw-wood effect, seat in woven cowhide color olive 5006. **Parker, screen** structure in oak with raw-wood effect, black cowhide straps, woven paper rush cord. **Adler, side tables** structure in oak with raw-wood effect, metal feet in matt titanium 710, top in oak with raw-wood effect. **Piuma, storage unit** structure veneered in oak with raw-wood effect, metal feet in matt titanium 710. **Happy, chaise longues** seat and backrest cushions upholstered in Elettra 201 fabric, backrest in woven cowhide color olive 5006, metal structure clad in cowhide color olive 5006, metal feet in matt titanium 710.

Mori, rug wool and cotton, Milk color, Juma design.

SOFT SHAPES THAT CAN BE
GROUPED DIFFERENTLY USHER
IN A NEW INTERPRETATION
OF CONTEMPORARY LIVING.

MODULI DI SEDUTA LINEARI, POUF, CHAISE LONGUE CONSENTONO AL SISTEMA PERRY
DI SODDISFARE INTERAMENTE SIA ESIGENZE DI OSPITALITÀ CHE DI RELAX.

LINEAR SEATING MODULES, OTTOMANS AND CHAISE LONGUES ALLOW THE PERRY SYSTEM
TO COMPLETELY SATISFY THE NEEDS OF HOSPITABLE ENTERTAINING AND RELAXATION.

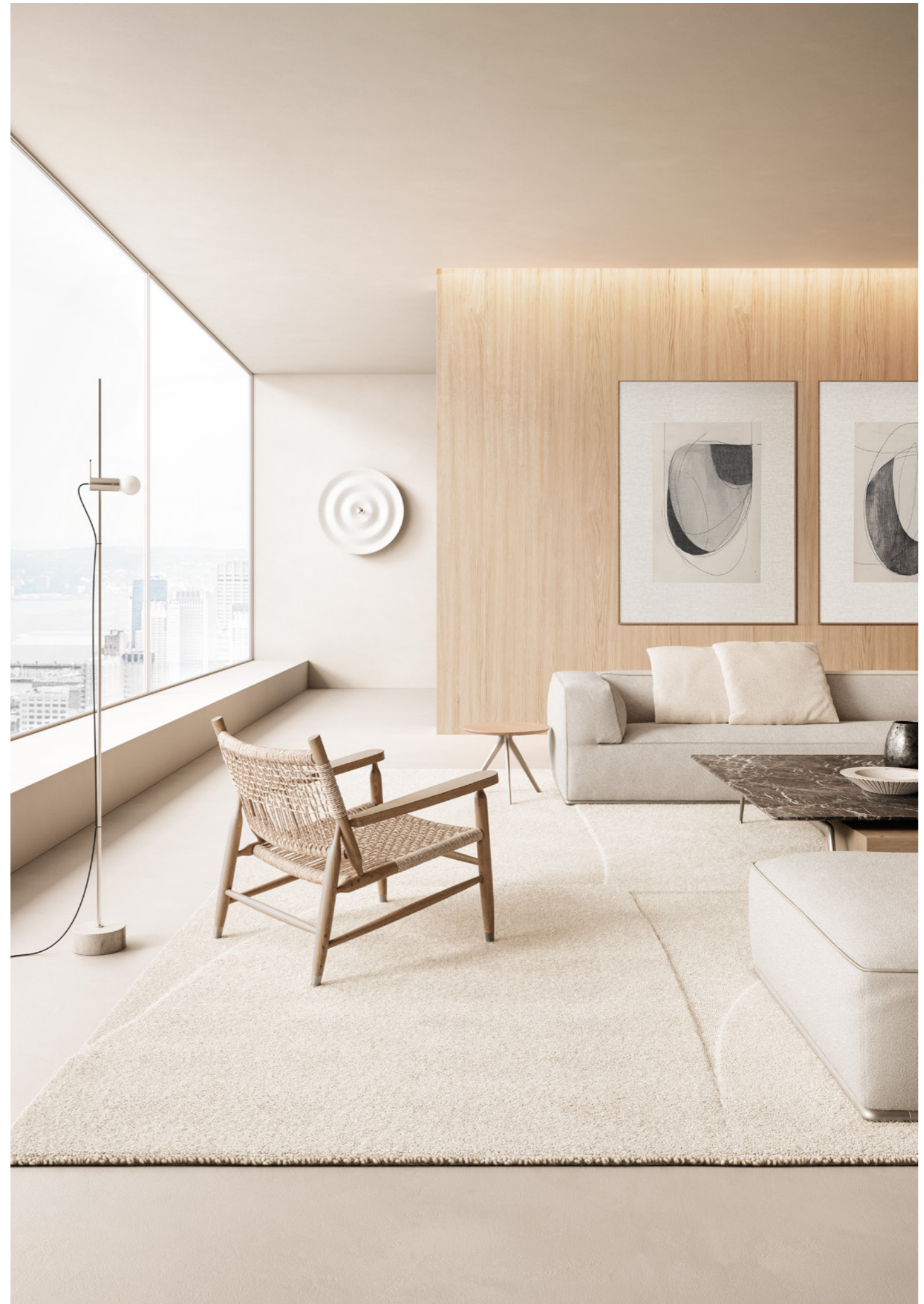



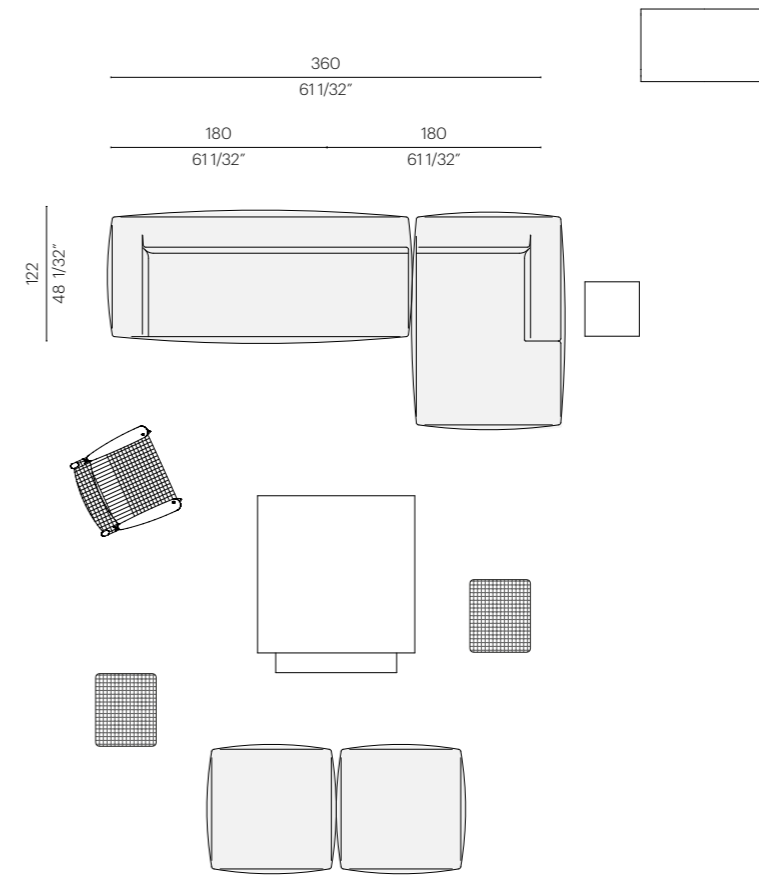

Perry, divano componibile e pouf base in alluminio color antracite lucido, cuscini di seduta e schienale rivestiti in tessuto Montgomery 1191, profilo in gros grain 10103, cuscini optional rivestiti in tessuto Eleo 1188. **Tessa, poltrona** struttura in rovere effetto grezzo, piedi in titanium opaco 710, intreccio in paglia di fiume. **Este, tavolino** struttura in metallo titanium opaco 710, piano in marmo grigio Stardust opaco. **Piuma, contenitore e cabinet** struttura impiallacciata in rovere effetto grezzo, piedi in metallo titanium opaco 710. **Bangkok, pouf** seduta rivestita in cuoio intrecciato color oliva 5006, piedi in metallo titanium opaco 710, Design Center design. **Zefiro, tavolino** struttura in metallo titanium opaco 710, piano in marmo grigio Stardust opaco. **Inca, tappeto** lana e cotone, colore Pearl, Juma design.

Perry, sectional sofa and ottoman base in aluminum, glossy anthracite color, seat and backrest cushions upholstered in Montgomery 1191 fabric, grosgrain 10103 piping, optional cushions upholstered in Eleo 1188 fabric. **Tessa, armchair** structure in oak with raw-wood effect, metal feet in matt titanium 710, woven paper rush cord. **Este, coffee table** metal structure in matt titanium 710, top in matt grey Stardust marble. **Piuma, storage unit and cabinet** structure veneered in oak with raw-wood effect, metal feet in matt titanium 710. **Bangkok, ottoman** seat upholstered in woven cowhide color olive 5006, metal feet in matt titanium 710, Design Center design. **Zefiro, side table** metal structure in matt titanium 710, top in matt grey Stardust marble. **Inca, rug** wool and cotton, Pearl color, Juma design.

LINEAR, CORNER AND ASYMMETRICAL
SHAPES MAP A GEOGRAPHY OF LIVING
THAT IS SURPRISING, ELEGANT AND NOVEL.

LA VARIETÀ DEGLI ELEMENTI DI SEDUTA, INSIEME AGLI ALTRI MODULI A DISPOSIZIONE,
PERMETTE UN'AMPIA POSSIBILITÀ COMPOSITIVA, IN GRADO DI RISPONDERE A SVARIATE FUNZIONI
E DEFINIRE SOLUZIONI PROGETTUALI ESCLUSIVE.

THE VARIETY OF SEATING ELEMENTS, ALONG WITH THE OTHER AVAILABLE MODULES,
ALLOWS NUMEROUS POSSIBILITIES OF ARRANGEMENT, SUITABLE FOR VARIOUS FUNCTIONS
AND TO DEFINE EXCLUSIVE DESIGN SOLUTIONS.







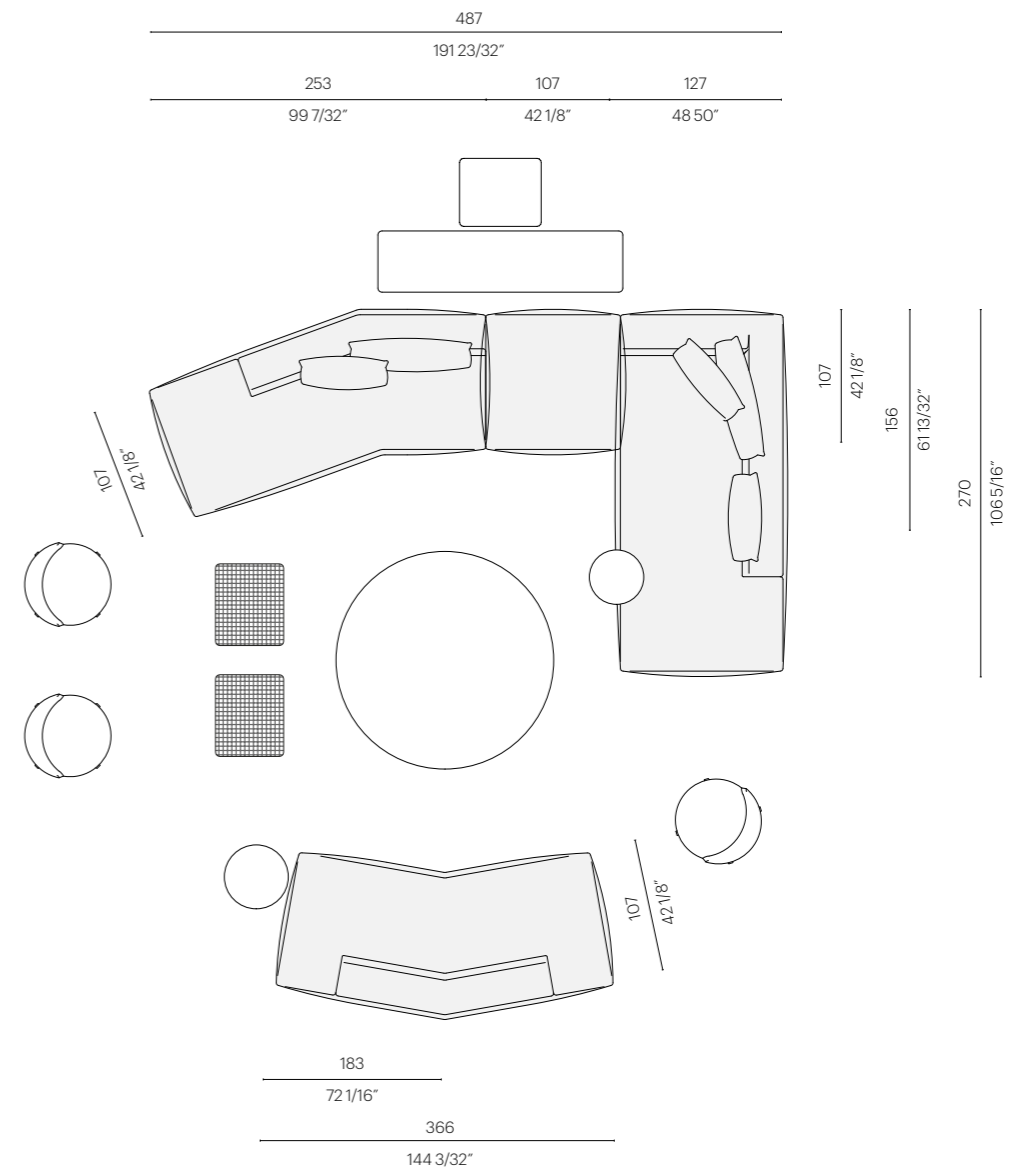

Perry, divano componibile base in alluminio color antracite lucido, cuscini di seduta, schienale e optional rivestiti in tessuto Elettra 200, profilo in gros grain 162. **Arnold, tavolino** struttura e piedi in noce canaletto naturale, piano in vetro retroverniciato Cacao lucido 2025. **Feel Good, poltrone** schienale e cuscino rivestiti in Nabuk Deluxe 701, piedi in metallo satinato. **Jiff, tavolini e consolle** struttura e piano in noce Canaletto naturale, Design Center design. **Bangkok, pouf** seduta rivestita in cuoio scamosciato intrecciato color testa di moro 6004, piedi in metallo satinato, Design Center design **Inca, tappeto** lana e cotone, colore Pearl, Juma design.

Perry, sectional sofa base in aluminum, glossy anthracite color, seat, backrest and optional cushions upholstered in Elettra 200 fabric, grosgrain 162 piping. **Arnold, coffee table** structure and feet in natural Canaletto walnut, top in glass back-painted glossy Cacao 2025. **Feel Good, armchairs** backrest and cushion upholstered in Nubuck Deluxe 702, feet in satin finish metal. **Jiff, side tables and console** structure and top in natural Canaletto walnut, Design Center design. **Bangkok, ottomans** seat upholstered in woven cowhide suede color dark brown 6004, feet in satin finish metal, Design Center design. **Inca, rug** wool and cotton, Pearl color, Juma design.

STRUTTURA

in legno massello con imbottitura
in poliuretano espanso a densità variabile
rivestito in tessuto protettivo accoppiato
e strato esterno in piuma d'oca sterilizzata
(certificata Assopiuma, etichetta Oro)

BRACCIOLO PORTARIVISTE

in metallo rivestito in cuoio nei colori
bianco 5007, sabbia 5001, oliva 5006,
tabacco 5015, rosso bulgaro 5008,
testa di moro 5004, testa di moro scuro 5013,
grigio 5003, nero 5005, scamosciato moro
6004, scamosciato nero 6005, scamosciato
oliva 6003, scamosciato sabbia 6001.

Base in metallo verniciato a forno con polveri
epossidiche di colore antracite lucido.
Appoggio a terra su piedi in materiale
termoplastico.

CUSCINI OPTIONAL

in piuma d'oca sterilizzata
(certificata Assopiuma, etichetta Oro),
a richiesta con supplemento di prezzo

BASE DIVANO E BRACCIOLO

in metallo verniciato a forno con polveri
epossidiche di colore antracite lucido.
Appoggio a terra su piedi in materiale
termoplastico

RIVESTIMENTO

sfoderabile sia nella versione in tessuto
che nella versione in pelle

PROFILO RIVESTIMENTO

la confezione prevede un profilo in gros grain
che può essere realizzato in tutti i colori
della cartella campioni, anche nella finitura
in PVC/effetto pelle.

STRUCTURE

in solid wood with variable
density polyurethane foam padding enveloped
in protective laminated fabric
and an external layer of sterilized goose down
(Assopiuma certified, Gold label)

MAGAZINE-HOLDER ARMREST

in metal, clad in cowhide in these colors
white 5007, sand 5001, olive 5006,
tobacco 5015, Bulgarian red 5008,
dark brown 5004, extra dark brown 5013,
grey 5003, black 5005, dark brown suede 6004,
black suede 6005, olive suede 6003,
sand suede 6001.

Base in epoxy powder-coated metal,
glossy anthracite color.
Sits on feet made of thermoplastic material.

OPTIONAL CUSHIONS

in sterilized goose down
(Assopiuma certified, Gold label);
upon request, with upcharge.

SOFA AND ARMREST BASE

in epoxy powder-coated metal,
glossy anthracite color.
Sits on feet made of thermoplastic material.

UPHOLSTERY

removable in both the fabric and leather versions.

UPHOLSTERY PIPING

tailoring detail includes grosgrain piping
that can be crafted in all the colors
on the sample board, including
in the PVC/leather-look finish.

DIVANO LINEARE | LINEAR SOFA

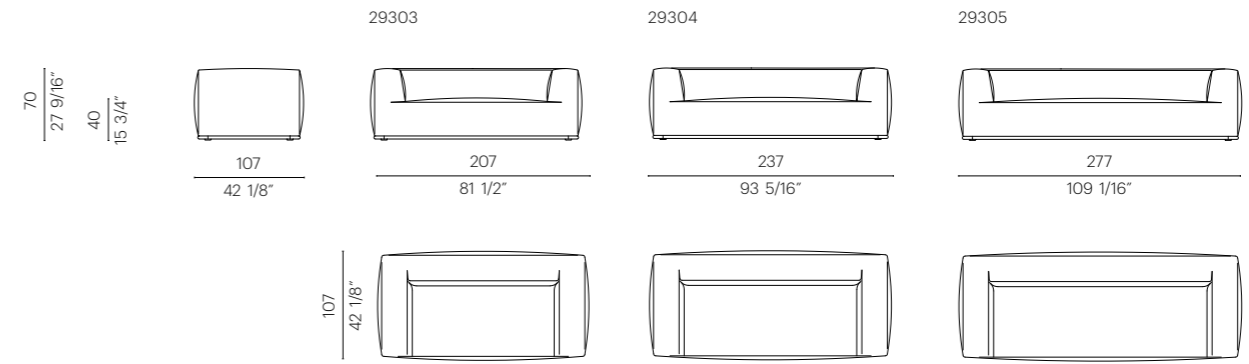

ELEMENTO | UNIT

FIANCO | END UNIT

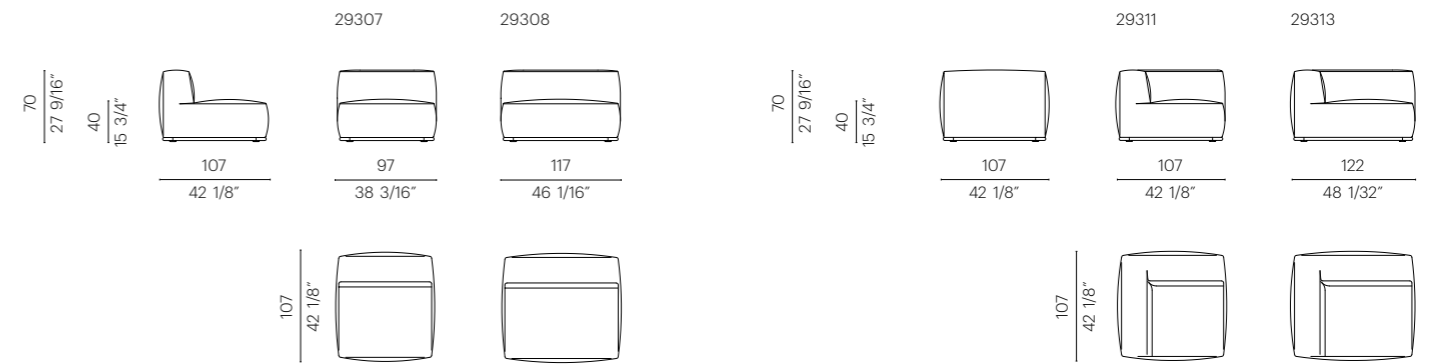

FIANCO | END UNIT

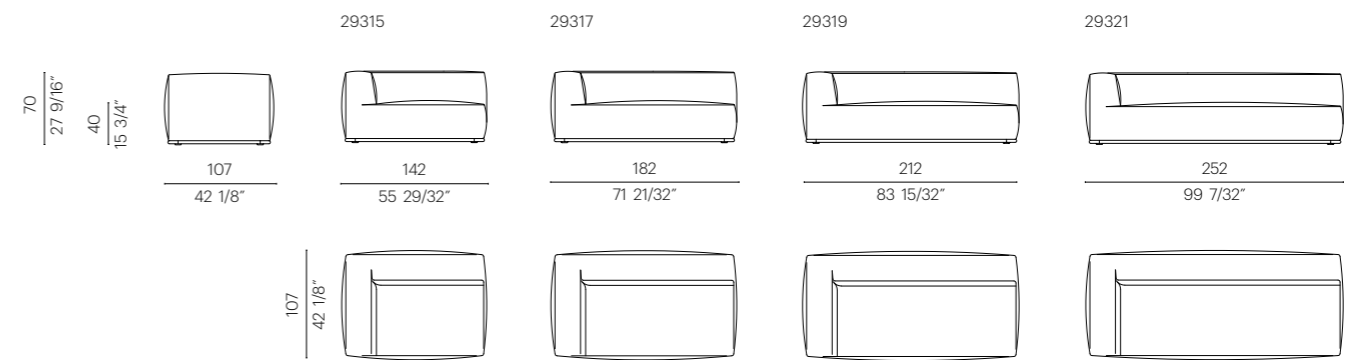

ELEMENTO TERMINALE | END UNIT

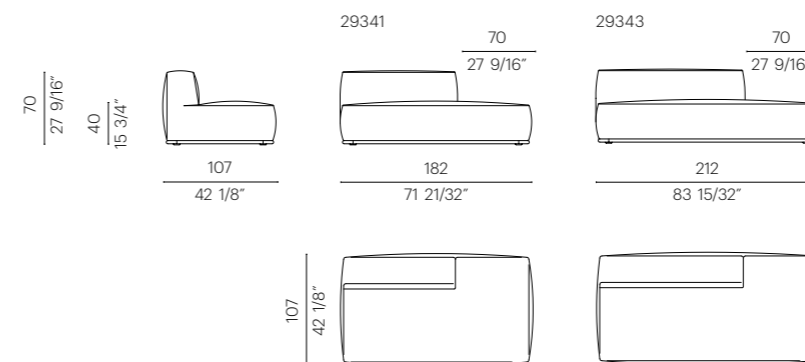

ELEMENTO | UNIT

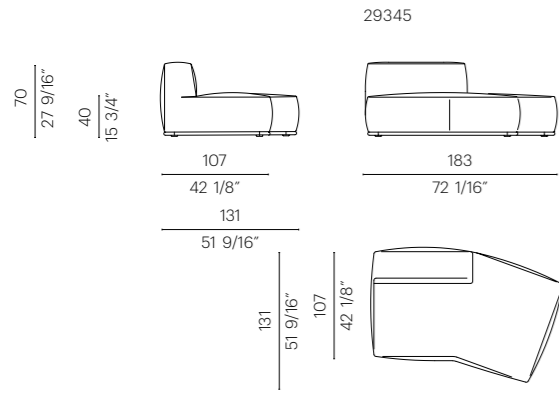

ELEMENTO | UNIT

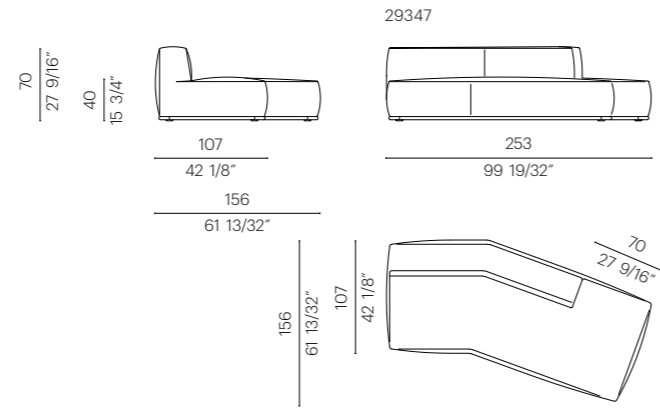

FIANCO | END UNIT

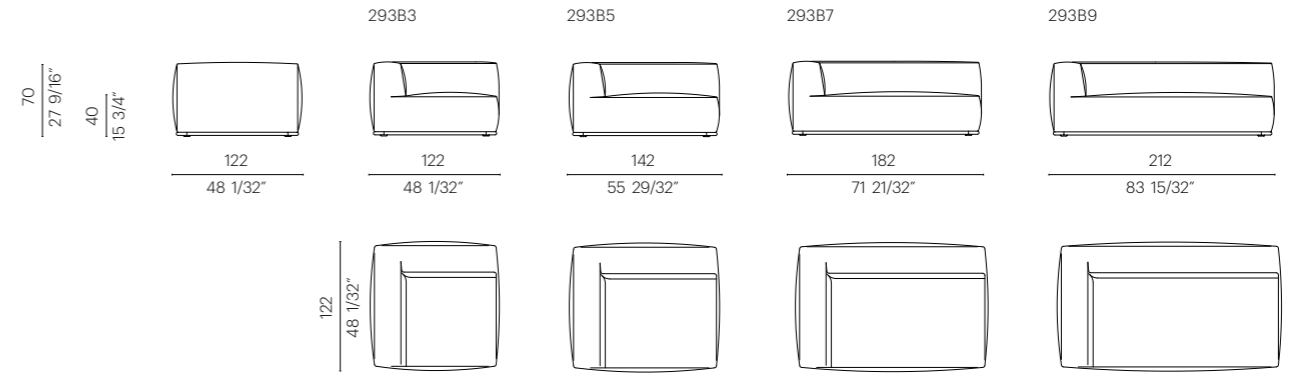

FIANCO | END UNIT

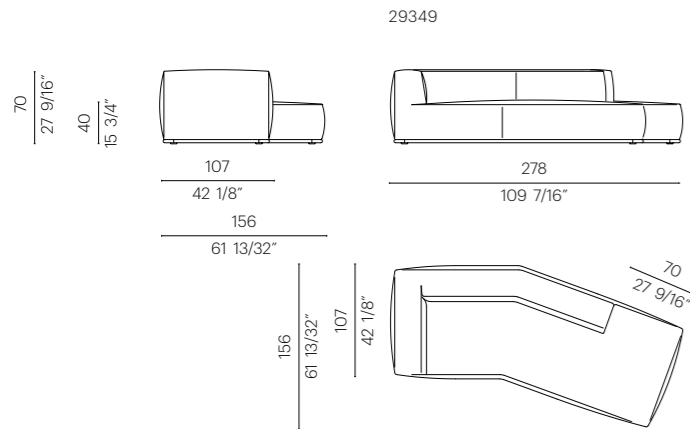

POUF | OTTOMAN

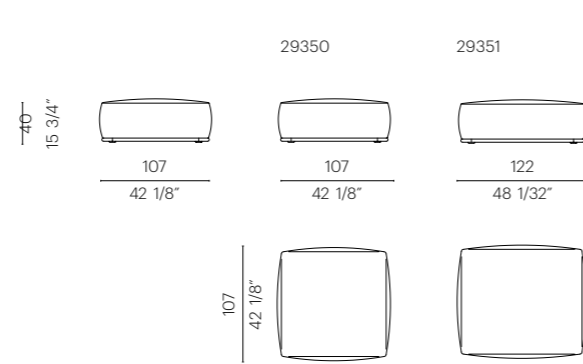

FIANCO | END UNIT

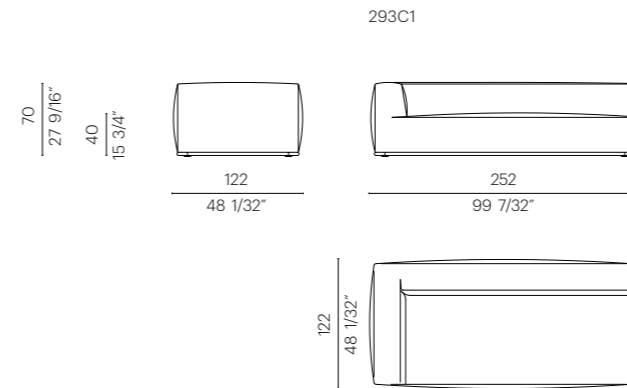

POUF | OTTOMAN

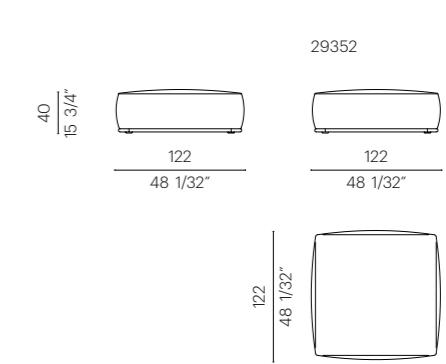

LINEARE | LINEAR

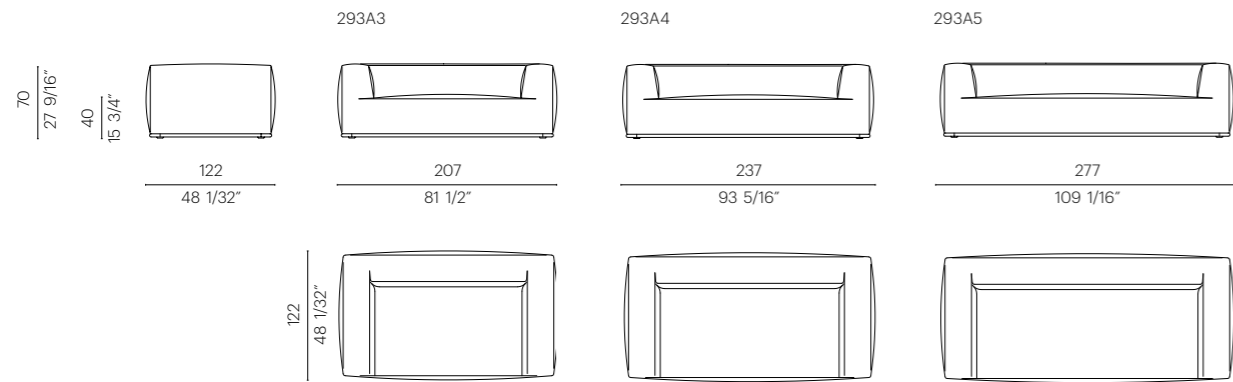

ELEMENTO TERMINALE | END UNIT

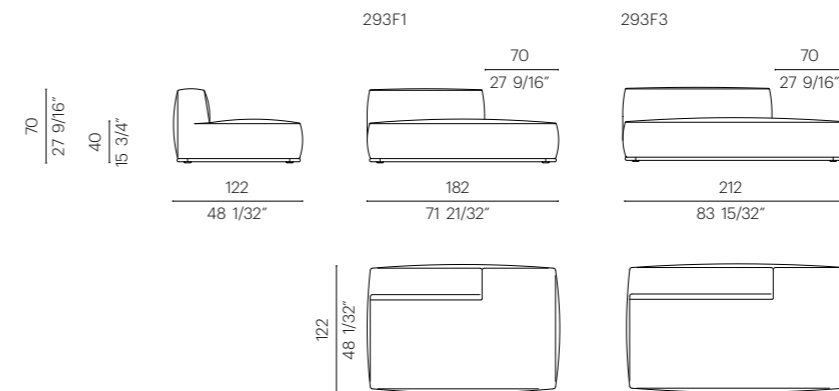

ELEMENTO | UNIT

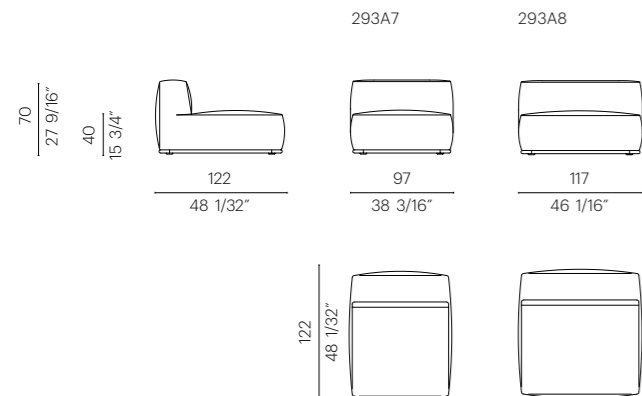

ELEMENTO | UNIT

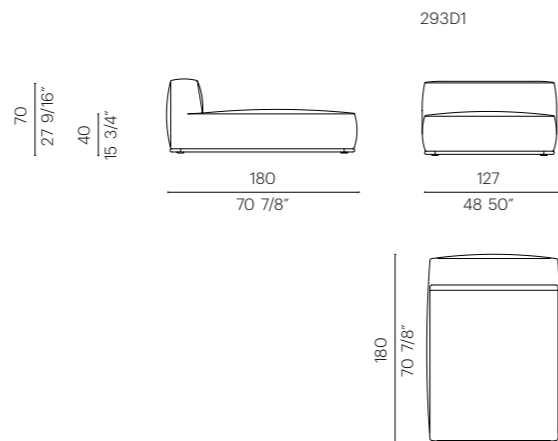

FIANCO TERMINALE | END UNIT

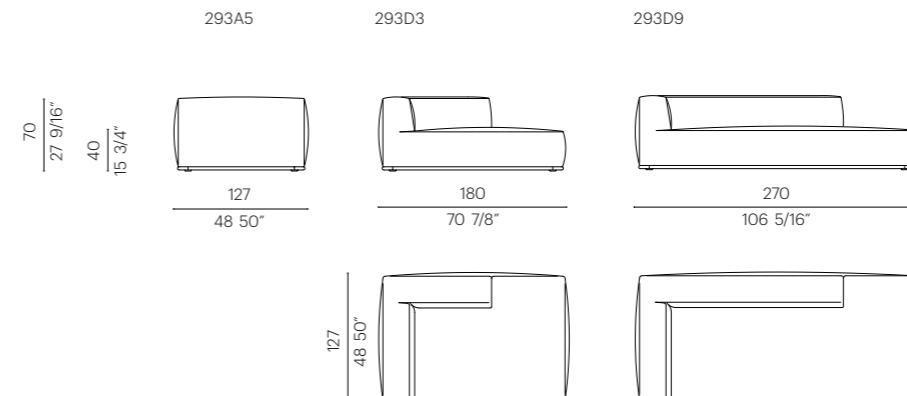

ELEMENTO BRACCIOLO | ARMREST UNIT

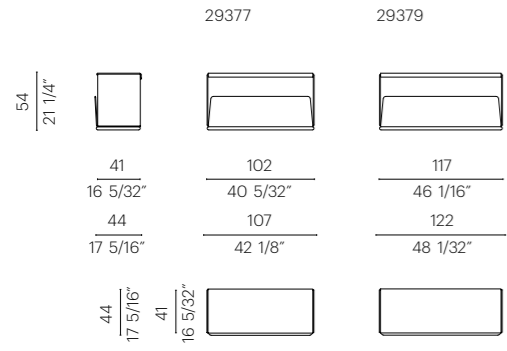

FIANCO TERMINALE | END UNIT

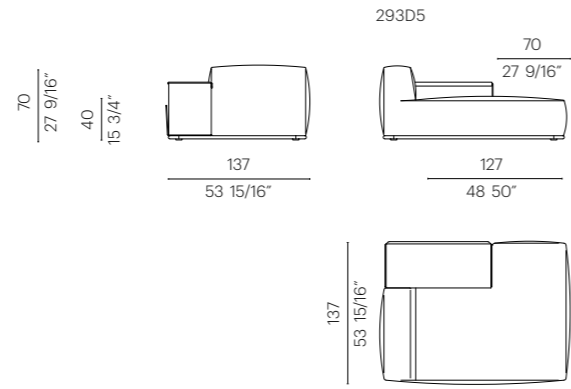

CUSCINI | CUSHIONS

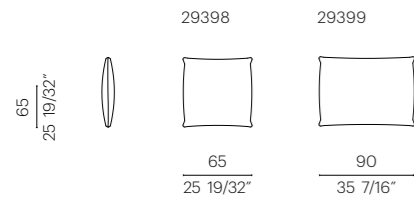

art direction
JUMA

images
SUPREMA UNLIMITED REALITY

styling
GAIA MARCHESINI
GIORDANO SARNO

October 2024
All rights are reserved.
No part of this publication may be reproduced, stored in a retrieval system or transmitted in any form or by any means, electronic, mechanical, photocopying, recording or otherwise, without prior consent of the company.

Flexform S.p.A.
Via Einaudi 23/25, 20821 Meda (MB) Italia | T +39 0362 3991
info@flexform.it www.flexform.it

Flexform reserves the right to make to its models any technological and aesthetical improvement, including modifications of sizes and materials, without prior notice.

